

USER MANUAL

KBR2D-C

CUSTOM[®]

CUSTOM S.p.A.
Via Berettine 2/B
43010 Fontevivo (PARMA) - Italy
Tel. : +39 0521-680111
Fax : +39 0521-610701
http: www.custom.biz

Customer Service Department:
www.custom4u.it

© 2020 CUSTOM S.p.A. – Italy.

All rights reserved. Total or partial reproduction of this manual in whatever form, whether by printed or electronic means, is forbidden. While guaranteeing that the information contained in it has been carefully checked, CUSTOM S.p.A. and other entities utilized in the realization of this manual bear no responsibility for how the manual is used. Information regarding any errors found in it or suggestions on how it could be improved are appreciated. Since products are subject to continuous check and improvement, CUSTOM S.p.A. reserves the right to make changes in information contained in this manual without prior notification.

The pre-installed multimedia contents are protected from Copyright CUSTOM S.p.A. Other company and product names mentioned herein may be trademarks of their respective companies. Mention of third-party products is for informational purposes only and constitutes neither an endorsement nor a recommendation. CUSTOM S.p.A. assumes no responsibility with regard to the performance or use of these products.

THE IMAGES USED IN THIS MANUAL ARE USED AS AN ILLUSTRATIVE EXAMPLES. THEY COULDN'T REPRODUCE THE DESCRIBED MODEL FAITHFULLY.

UNLESS OTHERWISE SPECIFIED, THE INFORMATION GIVEN IN THIS MANUAL ARE REFERRED TO ALL MODELS IN PRODUCTION AT THE ISSUE DATE OF THIS DOCUMENT.

GENERAL INSTRUCTIONS

CUSTOM S.p.A. declines all responsibility for accidents or damage to persons or property occurring as a result of tampering, structural or functional modifications, unsuitable or incorrect installations, environments not in keeping with the equipment's protection degree or with the required temperature and humidity conditions, failure to carry out maintenance and periodical inspections and poor repair work.

GENERAL SAFETY INFORMATION

Your attention is drawn to the following actions that could compromise the characteristics of the product:

- Read and retain the instructions which follow.
- Follow all indications and instructions given on the device.
- Make sure that the surface on which the device rests is stable. If it is not, the device could fall, seriously damaging it.
- Do not fix indissolubly the device or its accessories such as power supplies unless specifically provided in this manual.
- When positioning the device, make sure cables do not get damaged.
- Before any type of work is done on the machine, disconnect the power supply.
- Take care the operating temperature range of equipment and its ancillary components.
- Do not block the ventilation openings.
- Do not insert objects inside the device as this could cause short-circuiting or damage components that could jeopardize printer functioning.
- Do not carry out repairs on the device yourself, except for the normal maintenance operations given in the user manual.
- The equipment must be accessible on these components only to trained, authorized personnel.
- Periodically perform scheduled maintenance on the device to avoid dirt build-up that could compromise the correct, safe operation of the unit.
- Do not look directly into LED beam or reflect led beam from a mirrored surface, it may cause pain.
- Unplug or turn off the device be sure to stop the led beam before cleaning the portion of the device where LED light is generated and received (emitter/receiver). Otherwise, exposure may cause pain.



THE CE MARK AFFIXED TO THE PRODUCT CERTIFY THAT THE PRODUCT SATISFIES THE BASIC SAFETY REQUIREMENTS.

The device is in conformity with the essential Electromagnetic Compatibility and Electric Safety requirements laid down in Directives 2014/30/EU and 2014/35/EU.

The device is in conformity with the essential requirements laid down in Directives 2014/53/EU about devices equipped with intentional radiators. The Declaration of Conformity and other available certifications can be downloaded from the site www.custom4u.it.



GUIDELINES FOR THE DISPOSAL OF THE PRODUCT

The crossed-out rubbish bin logo means that used electrical and electronic products shall NOT be mixed with unsorted municipal waste. For more detailed information about recycling of this product, refer to the instructions of your country for the disposal of these products.

- Do not dispose of this equipment as miscellaneous solid municipal waste, but arrange to have it collected separately.
- The re-use or correct recycling of the electronic and electrical equipment (EEE) is important in order to protect the environment and the wellbeing of humans.
- In accordance with European Directive WEEE 2012/19/EU, special collection points are available to which to deliver waste electrical and electronic equipment and the equipment can also be handed over to a distributor at the moment of purchasing a new equivalent type.
- The public administration and producers of electrical and electronic equipment are involved in facilitating the processes of the re-use and recovery of waste electrical and electronic equipment through the organisation of collection activities and the use of appropriate planning arrangements.
- Unauthorised disposal of waste electrical and electronic equipment is punishable by law with the appropriate penalties.



The format used for this manual improves use of natural resources reducing the quantity of necessary paper to print this copy.

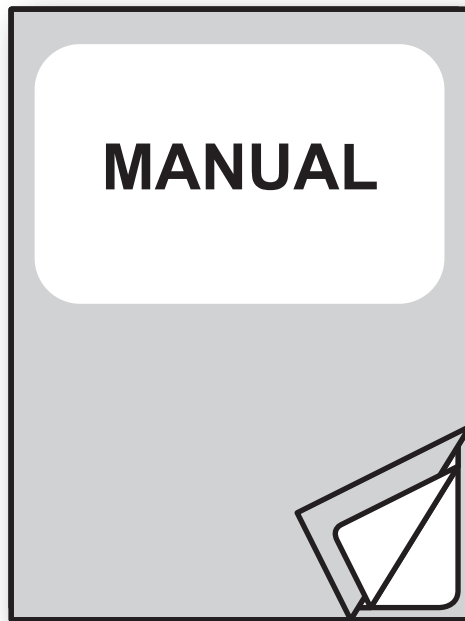

For details on the commands,
refer to the manual with code **0577200M000063**

For details on the configuration,
refer to the manual with code **0577200M000064**

TABLE OF CONTENTS

1	READABLE SYMBOLOGIES	9
1.1	1D symbologies	9
1.2	2D symbologies	10
2	DEPTH OF FIELD	11
3	PINOUT	13
4	SPECIFICATION	15
4.1	Hardware specifications	15
4.2	Device dimensions	17
4.3	USB power cord (Virtual COM port)	18





1 READABLE SYMBOLOGIES

1.1 1D symbologies

1D SYMBOLOGIES	READABLE	DEFAULT ENABLE
UPC-A	v	v
UPC-B	v	v
EAN-8/JAN-8	v	v
EAN-13/JAN-13	v	v
Code 39	v	v
Code 128	v	v
Codabar/NW7	v	v
Interleaved 25	v	v
Industrial 25	v	
Matrix 25	v	
Code 93	v	
China Post	v	
Code 11	v	
MSI/Plessey	v	
Telepen	v	
GS1 Databar Omni-directional	v	
GS1 Databar Limited	v	
GS1 Databar Expanded	v	



1.2 2D symbologies

2D SYMBOLOGIES	READABLE	DEFAULT ENABLE
Aztec	v	
Data Matrix	v	v
PDF 417	v	v
Micro PDF 417	Optional	
QR Code	v	v
Micro QR Code	v	
GM Code	Optional	
Han Xin Code	Optional	
Dot Code	v	

2 DEPTH OF FIELD

BARCODE	DEPTH OF FIELD
3mil Code39	from 50 mm to 90 mm
4mil Code39	from 45 mm to 100 mm
5mil Code39	from 40 mm to 120 mm
6mil Code39	from 30 mm to 40 mm
10mil Code39	from 30 mm to 200 mm
13mil Code39	from 30 mm to 230 mm
20mil Code39	from 30 mm to 280 mm
20mil QR Code	from 30 mm to 210 mm
20mil PDF417	from 30 mm to 120 mm
20mil Data Matrix	from 30 mm to 220 mm

- The test is under ambient light from 700 to 800 Lux.
- Reading area

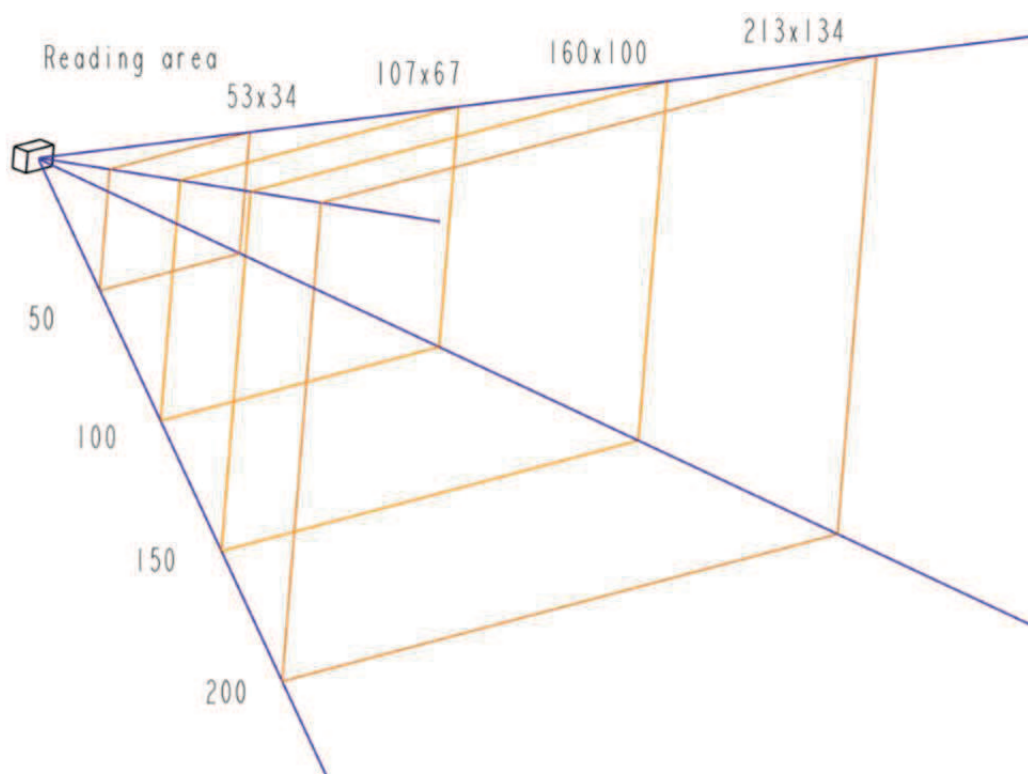



3 PINOUT



USB INTERFACE
Female USB type A connector

	1	VBUS-A	(in)
	2	HD-	
	3	HD+	
	4	GND	
		Frame GND	





4 SPECIFICATION

4.1 Hardware specifications

GENERAL	
Light source	white light LED
Sensor	1280 (H) x 800 (V) pixels
Field of view	horizontal: 55° vertical: 35°
Scan rate	60 fps (at full resolution)
Reading distance	280mm@20mil/0.5mm, PCS90%
Print contrast ratio	PCS30%@5mil/0.127mm
Resolution	3mil/0.076mm@PCS90% Code39, 8mil/0.2mm@PCS90% QRCode
Reading angle	(test conditions : Code 39, 10mil/0.25mm,PCS90%)
Pitch angle	from 5° to 60° (±5°)
Skew tolerance	from 5° to 60° (±5°)
Ambient light	lux max. 100000
ELECTRICAL SPECIFICATIONS	
Interface	USB-HID (or Virtual COM port)
Supply voltage	5 Vdc ± 5%
Current drawn	
Standby consumption	40 mA ±10%
Typical consumption	380 mA ±10%
RELIABILITY	
Life time	50000 hours
Thermal shock	high temperature 50 °C (122 °F) low temperature.-20 °C (-4 °F)
Mechanical shock	-20 °C (-4 °F) 2000 G, 0.7 ms, half sinus, 3 axes



ENVIRONMENTAL CONDITIONS

Operating temperature	from 0 °C to 50 °C (from 32 °F to 122 °F)
Storage temperature	from -20 °C to 70 °C (from -4 °F to 158 °F)
Relative humidity (RH)	from 20% to 95% (without condensation)



4.2 Device dimensions

All the dimensions shown in following figures are in millimetres.

Length	69 mm
Height	27.7 mm
Width	56 mm
Weight	85 g

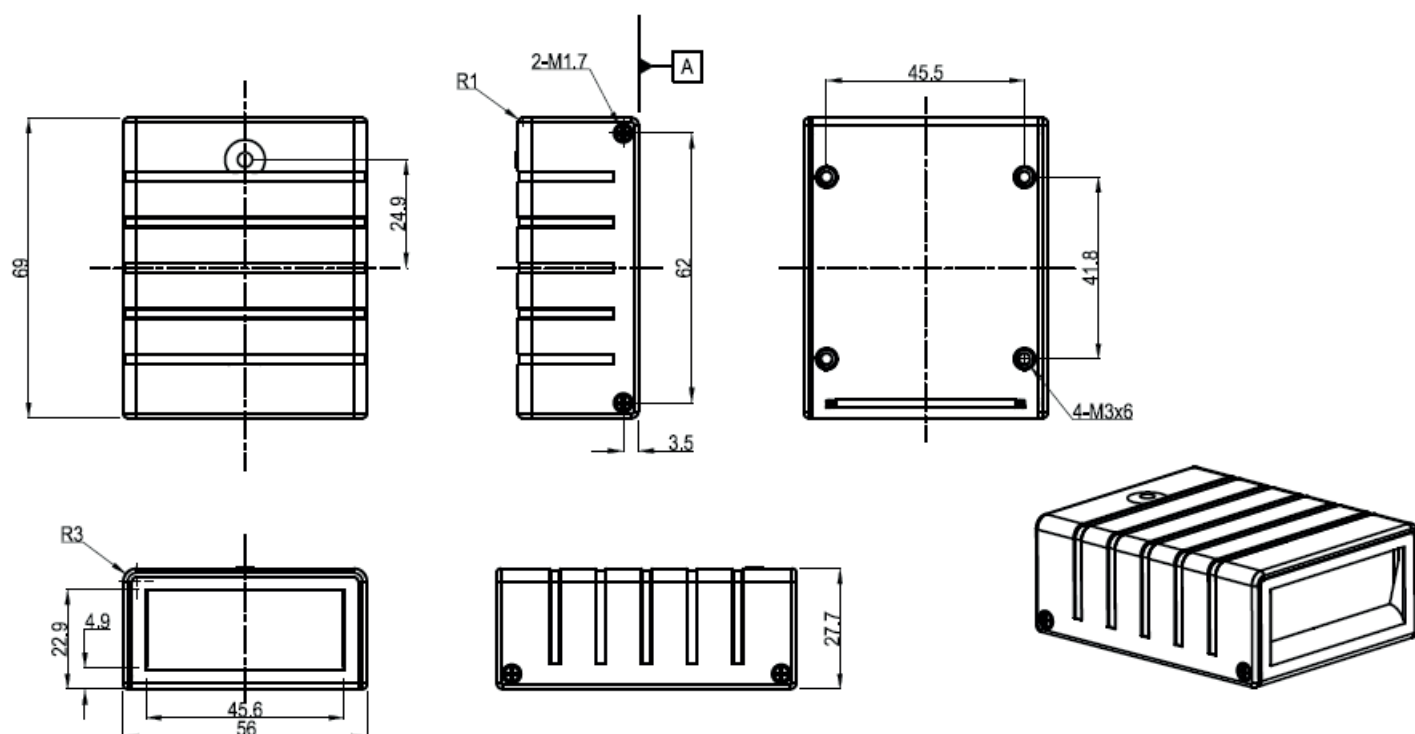

4.3 USB power cord (Virtual COM port)

All the dimensions shown in following figures are in millimetres.

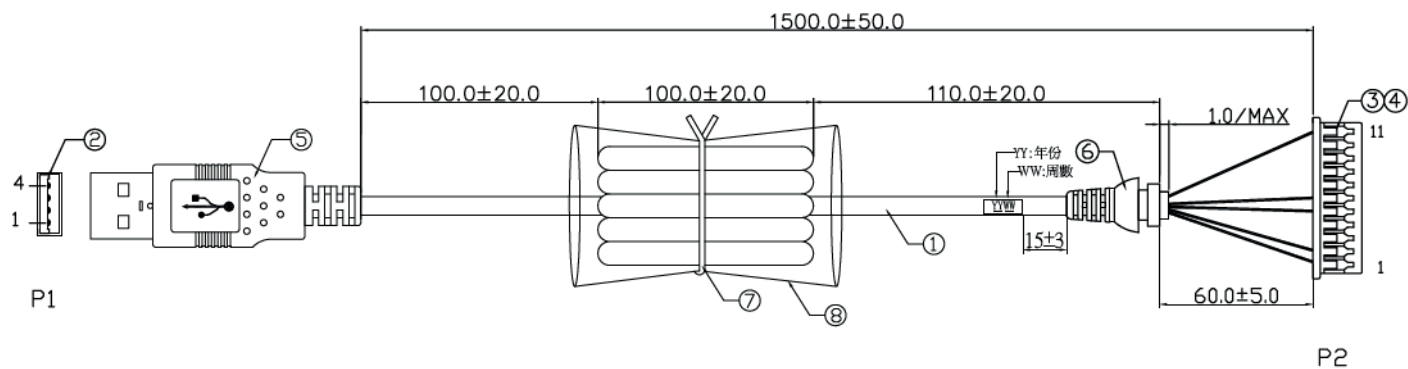

PIN ITEM			DESCRIPTION
P1	COLOR	P2	
1	Red	2	VCC
2	Blue	6	D-
3	Green	5	D+
4	Brown	1	GND
steel casing	wire-winding	11	SHIELDING



CUSTOM[®]

CUSTOM S.p.A.

World Headquarters

Via Berettine, 2/B - 43010 Fontevivo, Parma ITALY

Tel. +39 0521 680111 - Fax +39 0521 610701

info@custom.biz - www.custom.biz

All rights reserved

www.custom.biz