

USER MANUAL

SCANNER A6

CUSTOM[®]

CUSTOM S.p.A.
Via Berettine 2/B
43010 Fontevivo (PARMA) - Italy
Tel. : +39 0521-680111
Fax : +39 0521-610701
http: www.custom.biz

Customer Service Department:
www.custom4u.it

© 2022 CUSTOM S.p.A. – Italy.
All rights reserved. Total or partial reproduction of this manual in whatever form, whether by printed or electronic means, is forbidden. While guaranteeing that the information contained in it has been carefully checked, CUSTOM S.p.A. and other entities utilized in the realization of this manual bear no responsibility for how the manual is used. Information regarding any errors found in it or suggestions on how it could be improved are appreciated. Since products are subject to continuous check and improvement, CUSTOM S.p.A. reserves the right to make changes in information contained in this manual without prior notification.

The pre-installed multimedia contents are protected from Copyright CUSTOM S.p.A. Other company and product names mentioned herein may be trademarks of their respective companies. Mention of third-party products is for informational purposes only and constitutes neither an endorsement nor a recommendation. CUSTOM S.p.A. assumes no responsibility with regard to the performance or use of these products.

THE IMAGES USED IN THIS MANUAL ARE USED AS AN ILLUSTRATIVE EXAMPLES. THEY COULDN'T REPRODUCE THE DESCRIBED MODEL FAITHFULLY.

UNLESS OTHERWISE SPECIFIED, THE INFORMATION GIVEN IN THIS MANUAL ARE REFERRED TO ALL MODELS IN PRODUCTION AT THE ISSUE DATE OF THIS DOCUMENT.

GENERAL INSTRUCTIONS

CUSTOM S.p.A. declines all responsibility for accidents or damage to persons or property occurring as a result of tampering, structural or functional modifications, unsuitable or incorrect installations, environments not in keeping with the equipment's protection degree or with the required temperature and humidity conditions, failure to carry out maintenance and periodical inspections and poor repair work.

GENERAL SAFETY INFORMATION

Your attention is drawn to the following actions that could compromise the characteristics of the product:

- Read and retain the instructions which follow.
- Follow all indications and instructions given on the device.
- Make sure that the surface on which the device rests is stable. If it is not, the device could fall, seriously damaging it.
- Make sure that the device rests on a hard (non-padded) surface and that there is sufficient ventilation.
- Do not fix indissolubly the device or its accessories such as power supplies unless specifically provided in this manual.
- When positioning the device, make sure cables do not get damaged.
- [Only OEM equipment] The equipment must be installed in a kiosk or system that provides mechanical, electrical and fire protection.
- The mains power supply must comply with the rules in force in the Country where you intend to install the equipment.
- Make sure that there is an easily-accessible outlet with a capacity of no less than 10A closely to where the device is to be installed.
- Make sure the power cable provided with the appliance, or that you intend to use is suitable with the wall socket available in the system.
- Make sure the electrical system that supplies power to the device is equipped with a ground wire and is protected by a differential switch.
- Before any type of work is done on the machine, disconnect the power supply.
- Use the type of electrical power supply indicated on the device label.
- These devices are intended to be powered by a separately certified power module having an SELV, non-energy hazardous output. (IEC60950-1 second edition).
- [Only POS equipment] The energy to the equipment must be provided by power supply approved by CUSTOM S.p.A.
- Take care the operating temperature range of equipment and its ancillary components.
- Do not block the ventilation openings.
- Do not insert objects inside the device as this could cause short-circuiting or damage components that could jeopardize printer functioning.
- Do not carry out repairs on the device yourself, except for the normal maintenance operations given in the user manual.
- The equipment must be accessible on these components only to trained, authorized personnel.
- Periodically perform scheduled maintenance on the device to avoid dirt build-up that could compromise the correct, safe operation of the unit.
- Do not touch the head heating line with bare hands or metal objects. Do not perform any operation inside the printer immediately after printing because the head and motor tend to become very hot.
- Use consumables approved by CUSTOM S.p.A.



THE CE MARK AFFIXED TO THE PRODUCT CERTIFY THAT THE PRODUCT SATISFIES THE BASIC SAFETY REQUIREMENTS.

The device is in conformity with the essential Electromagnetic Compatibility and Electric Safety requirements laid down in Directives 2014/30/EU and 2014/35/EU inasmuch as it was designed in conformity with the provisions laid down in the following Standards:

- EN 55032 (*Electromagnetic compatibility of multimedia equipment - Emission Requirements*)
- EN 55024/EN55035 (*Electromagnetic compatibility of multimedia equipment - Immunity requirements*)
- EN IEC/EN62368-1 (*Audio/video, information and communication technology equipment*)

The device is in conformity with the essential requirements laid down in Directives 2014/53/EU about devices equipped with intentional radiators. The Declaration of Conformity and other available certifications can be downloaded from the site www.custom4u.it.



GUIDELINES FOR THE DISPOSAL OF THE PRODUCT

The crossed-out rubbish bin logo means that used electrical and electronic products shall NOT be mixed with unsorted municipal waste. For more detailed information about recycling of this product, refer to the instructions of your country for the disposal of these products.

- Do not dispose of this equipment as miscellaneous solid municipal waste, but arrange to have it collected separately.
- The re-use or correct recycling of the electronic and electrical equipment (EEE) is important in order to protect the environment and the wellbeing of humans.
- In accordance with European Directive WEEE 2012/19/EU, special collection points are available to which to deliver waste electrical and electronic equipment and the equipment can also be handed over to a distributor at the moment of purchasing a new equivalent type.
- The public administration and producers of electrical and electronic equipment are involved in facilitating the processes of the re-use and recovery of waste electrical and electronic equipment through the organisation of collection activities and the use of appropriate planning arrangements.
- Unauthorised disposal of waste electrical and electronic equipment is punishable by law with the appropriate penalties.



The format used for this manual improves use of natural resources reducing the quantity of necessary paper to print this copy.



FCC STATEMENT
(FEDERAL COMMUNICATIONS
COMMISSIONS).

This note is valid only for device bringing FCC trademark.

This device complies with Part 15 of the FCC Rules. Operation is subject to the following conditions:

The devices may not cause harmful interference.
The devices must accept any interference received, including interference that may cause undesired operation.

NOTE: This equipment has been tested and found to comply with the limits for a Class B digital device, pursuant to Part 15 of the FCC Rules. These limits are designed to provide reasonable protection against harmful interference in a residential installation. This equipment generates, uses and can radiate radio frequency energy and, if not installed and used in accordance with the instructions, may cause harmful interference to radio communications. However, there is no guarantee that interference will not occur in a particular installation. If this equipment does cause harmful interference to radio or television reception, which can be determined by turning the equipment off and on, the user is encouraged to try and correct the interference by one or more of the following measures:

Reorient or relocate the receiving antenna.
Increase the separation between the equipment and receiver.
Connect the equipment into an outlet on a circuit different from that to which the receiver is connected.
Consult the dealer or an experienced radio/TV technician for help.

Modifications to this product not authorized by CUSTOM S.p.A. could void the FCC & Industry Canada regulations and negate your authority to operate the product.

This Class B digital apparatus complies with Canadian ICES-003.
Cet appareil numérique de la classe B est conforme à la norme NMB-003 du Canada.

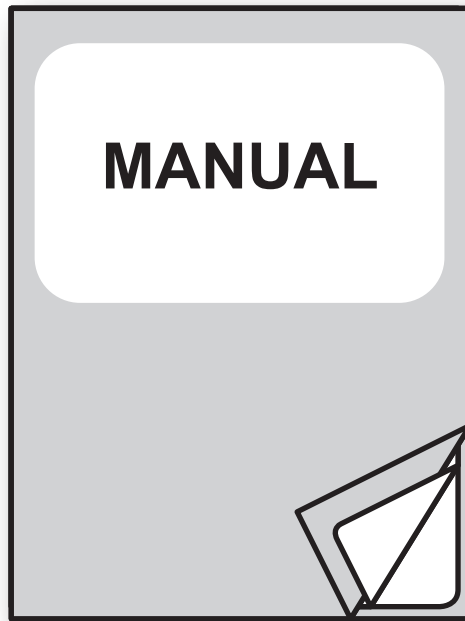

For further information about the use of "PrinterSet" tool
refer to the manual with code **78200000001800**

TABLE OF CONTENTS

1	INTRODUCTION	9
2	IDENTIFICATION OF THE MODELS	11
3	DESCRIPTION	13
3.1	Box contents	13
3.2	Device components: external views	14
3.3	Device components: internal view	15
3.4	Product label	16
3.5	Status messages	17
4	INSTALLATION	19
4.1	Fastening	19
4.2	Connections	21
4.3	Pinout	22
4.4	Driver and tools	23
5	OPERATION	25
5.1	Opening the cover	27
5.2	Switch the device ON/OFF	28
5.3	Ticket management	29
6	MAINTENANCE	33
6.1	Paper jam	33
6.2	Cleaning	35
6.3	Firmware upgrade	38
7	SPECIFICATIONS	41
7.1	Hardware specifications	41
7.2	Device dimensions	44
7.3	Power supply, power cord and adapter for power supply dimensions	45
8	ACCESSORIES	47
9	TECHNICAL SERVICE	49



1 INTRODUCTION

This document is divided into sections and chapters. Each chapter can be reached by the index at the beginning of this document. The index can be reached by the button on each page as shown in the diagram below.

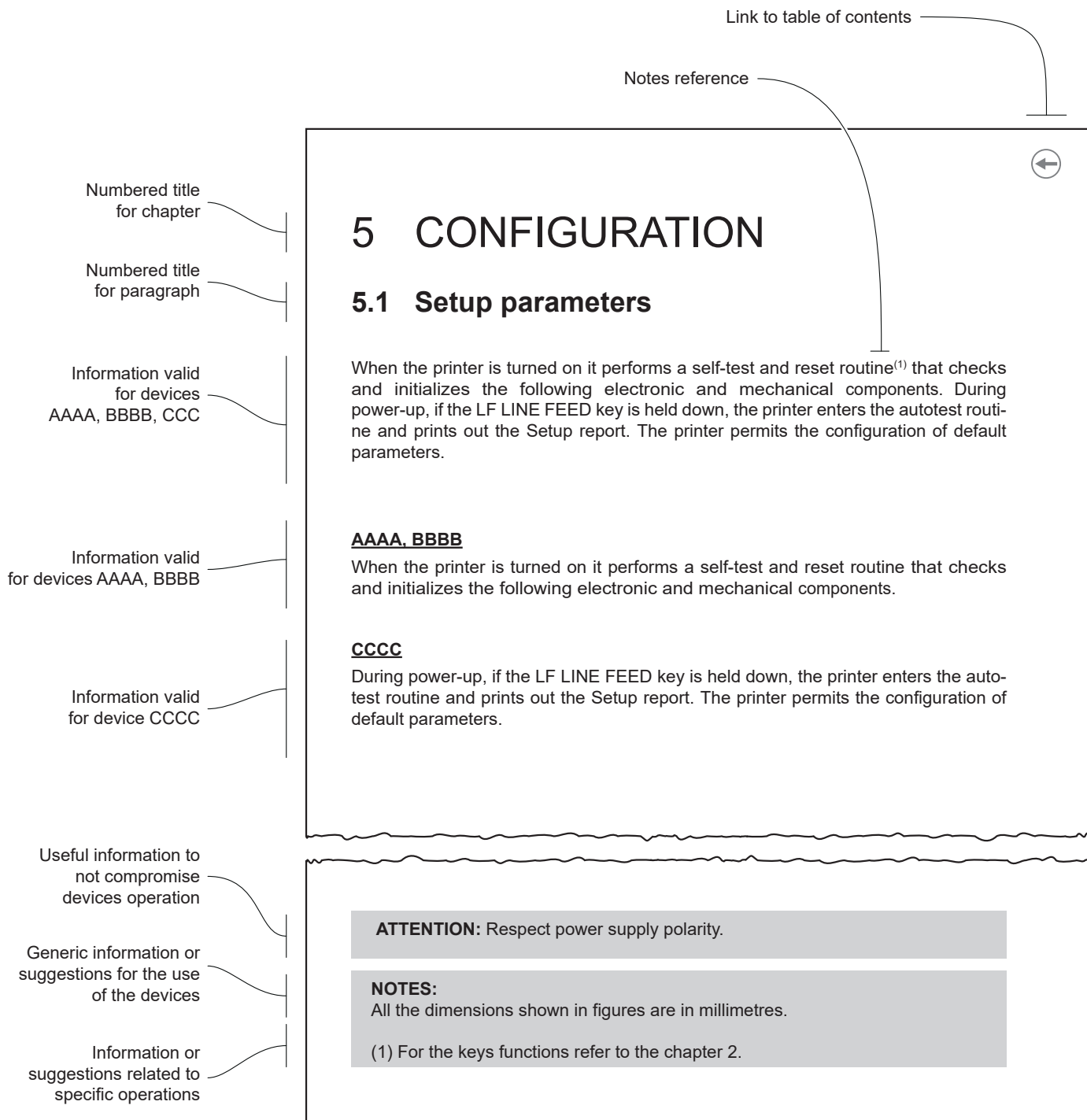





2 IDENTIFICATION OF THE MODELS

NOMENCLATURE	DESCRIPTION
SCANNER A6	SCANNER A6 base configuration
SCANNER A6 MSR	SCANNER A6 with MICR reader
SCANNER A6 MSR US	SCANNER A6 with MICR reader and ultrasonic sensor



3 DESCRIPTION

3.1 Box contents

Remove all the box contents (see following figures) being careful not to damage the packing material so that it may be re-used if the device is to be transported in the future.

Make sure that all the components illustrated below are present and that there are no signs of damage. If there are, contact customer service.

1. Documentation (installation instruction)
2. Power supply cable
3. Device

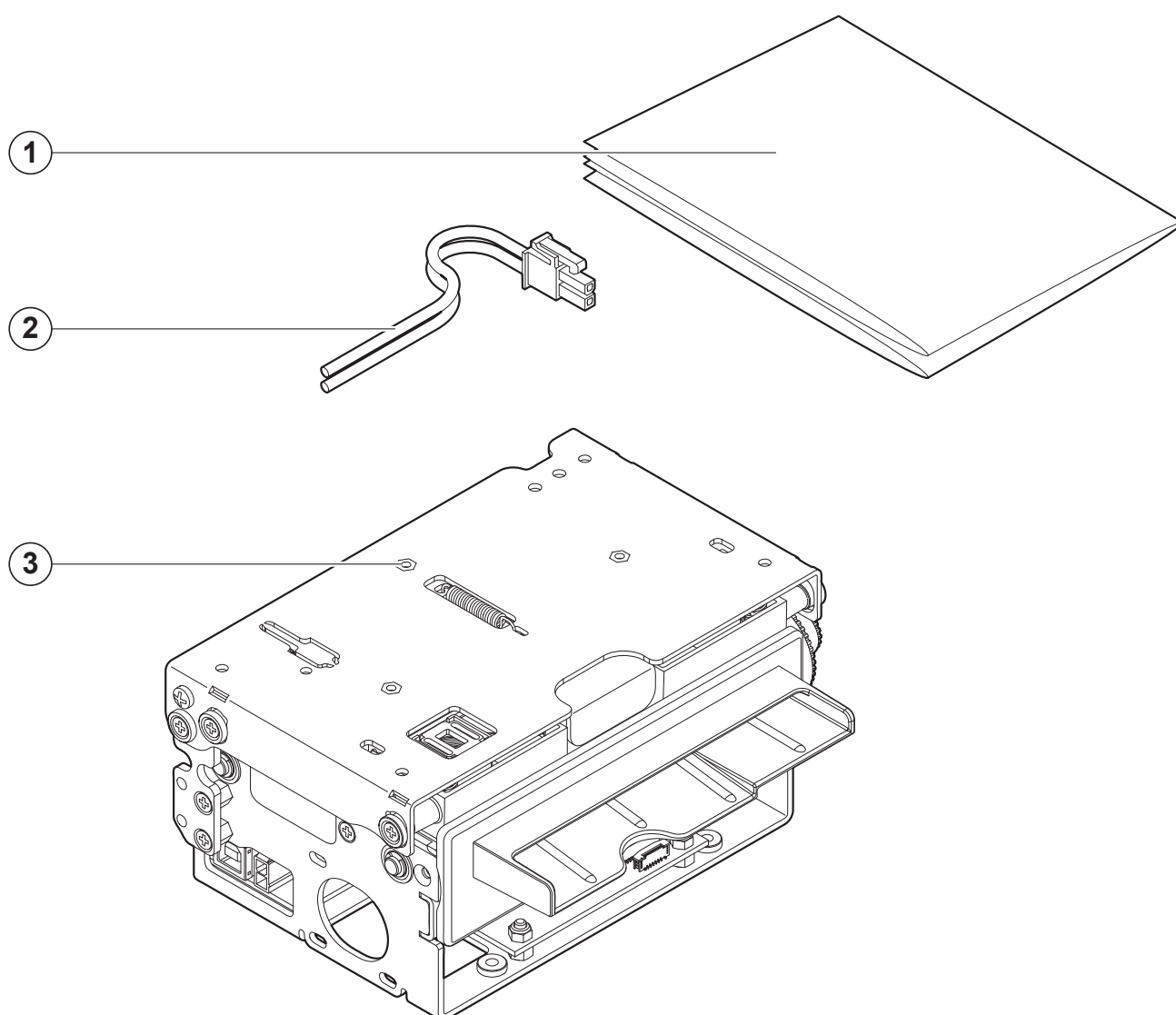



3.2 Device components: external views

- 1. Device cover
- 2. Opening cover lever
- 3. USB port
- 4. Power supply port
- 5. Status LED
- 6. Paper output
- 7. Paper input bezel with status LED

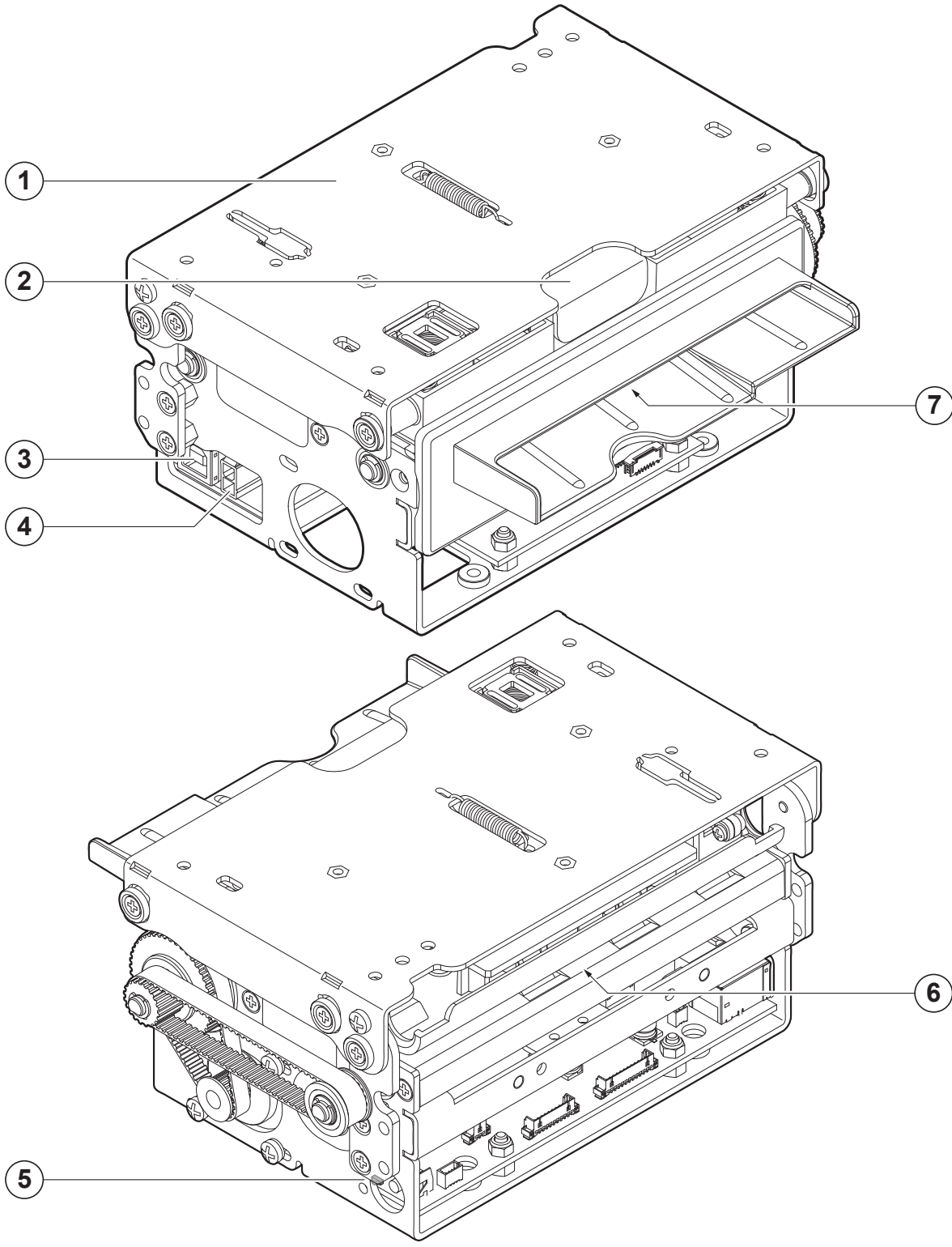

3.3 Device components: internal view

- | | |
|--|---|
| 1. Paper input presence sensors | 5. Lower CIS |
| 2. MICR reader (only for SCANNER A6 MSR and SCANNER A6 MSR US) | 6. Ultrasonic sensor (only for SCANNER A6 MSR US) |
| 3. Upper CIS | 7. Paper holder sensor |
| 4. Paper output presence sensor | 8. Opening cover sensor |

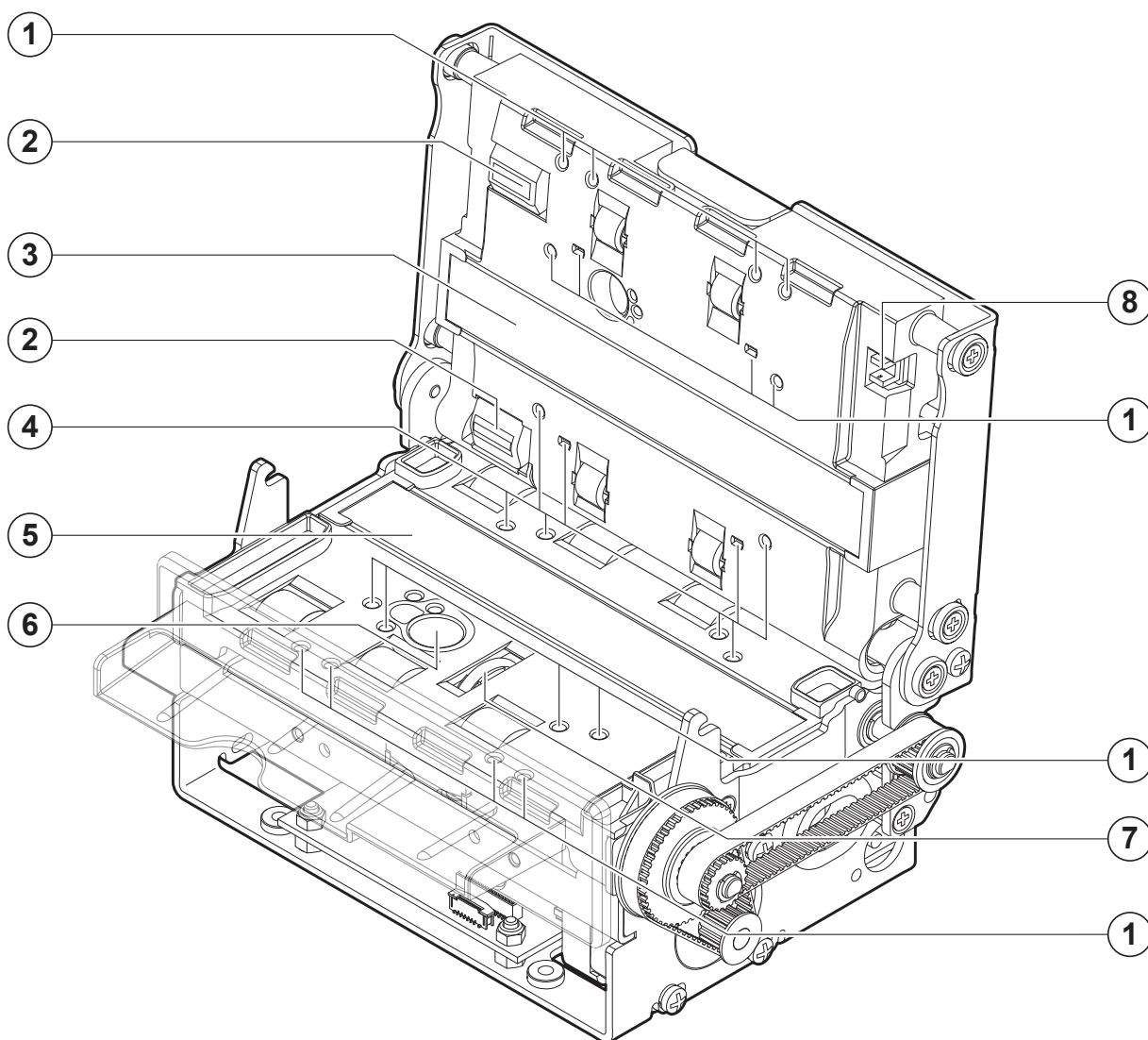



3.4 Product label

The main data used to identify the machine are shown on the label attached to the bottom of the device. In particular, it shows the electrical data for the connection to a power source. It also shows the product code, the serial number and the hardware revision (R).

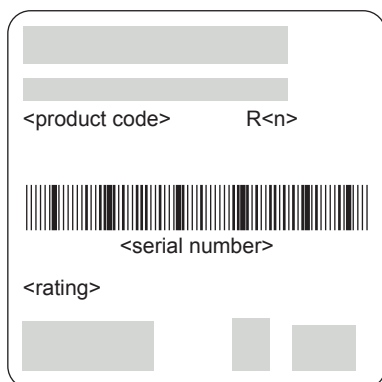



3.5 Status messages

The Status LED indicates hardware status of device. Given in the table below are the various led signals and the corresponding device status.

STATUS LED		DESCRIPTION
-	OFF	DEVICE OFF
GREEN	ON	DEVICE ON: NO ERROR
GREEN COMMUNICATION STATUS	x 1	RECEIVE DATA
	x 2	RECEPTION ERRORS (PARITY, FRAME ERROR, OVERRUN ERROR)
	x 3	COMMAND NOT RECOGNIZED
	x 4	COMMAND RECEPTION TIME OUT
YELLOW RECOVERABLE ERROR	x 2	DEVICE OVERHEATED
	x 4	PAPER JAM
	x 5	POWER SUPPLY VOLTAGE INCORRECT
	x 6	COVER OPEN
RED UNRECOVERABLE ERROR	x 2	FPGA ERROR
	x 3	RAM ERROR
	x 4	EEPROM ERROR





4 INSTALLATION

4.1 Fastening

The device is provided with four fixing holes on the bottom of device (see following figure). To secure the device into a kiosk, use four M4 screws.
All the dimensions shown in following figures are in millimetres.

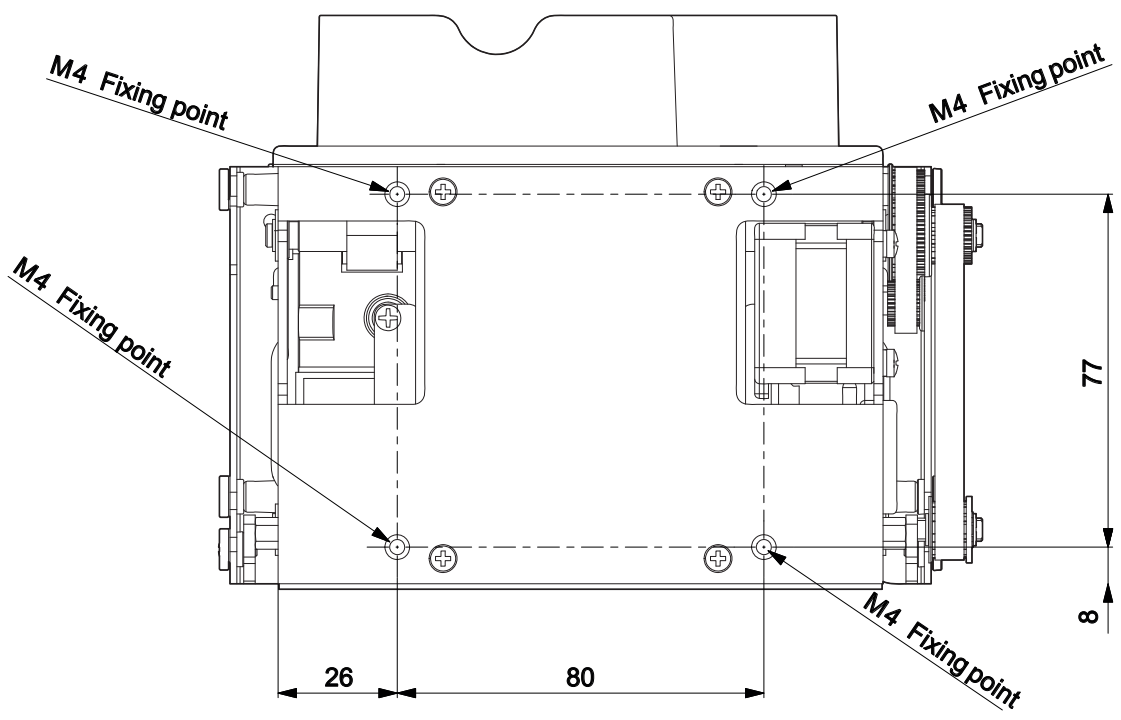

It's very important to consider the screws length not to damage the internal components placed near the fixing holes (see following figure).

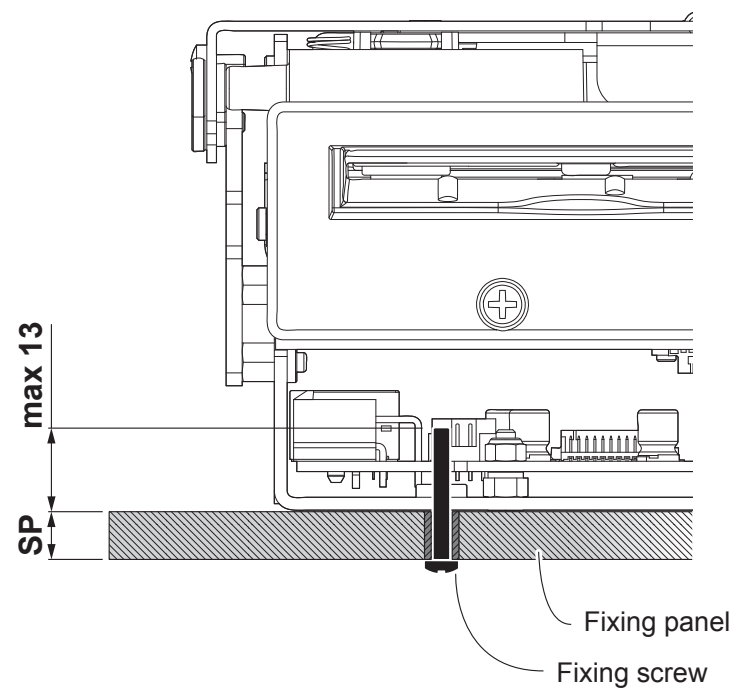



The screw length (L) will be calculated according to the thickness of the panel (Sp) on which the device is fixed, as follows:

$$L \leq 10 \text{ mm} + Sp$$

For example, if panel thickness is 10 mm (Sp = 10 mm), the maximum length for screws will be 23 mm.

Additionally, the front panel must provide an opening for the paper input that meets the following measures (in millimetres).

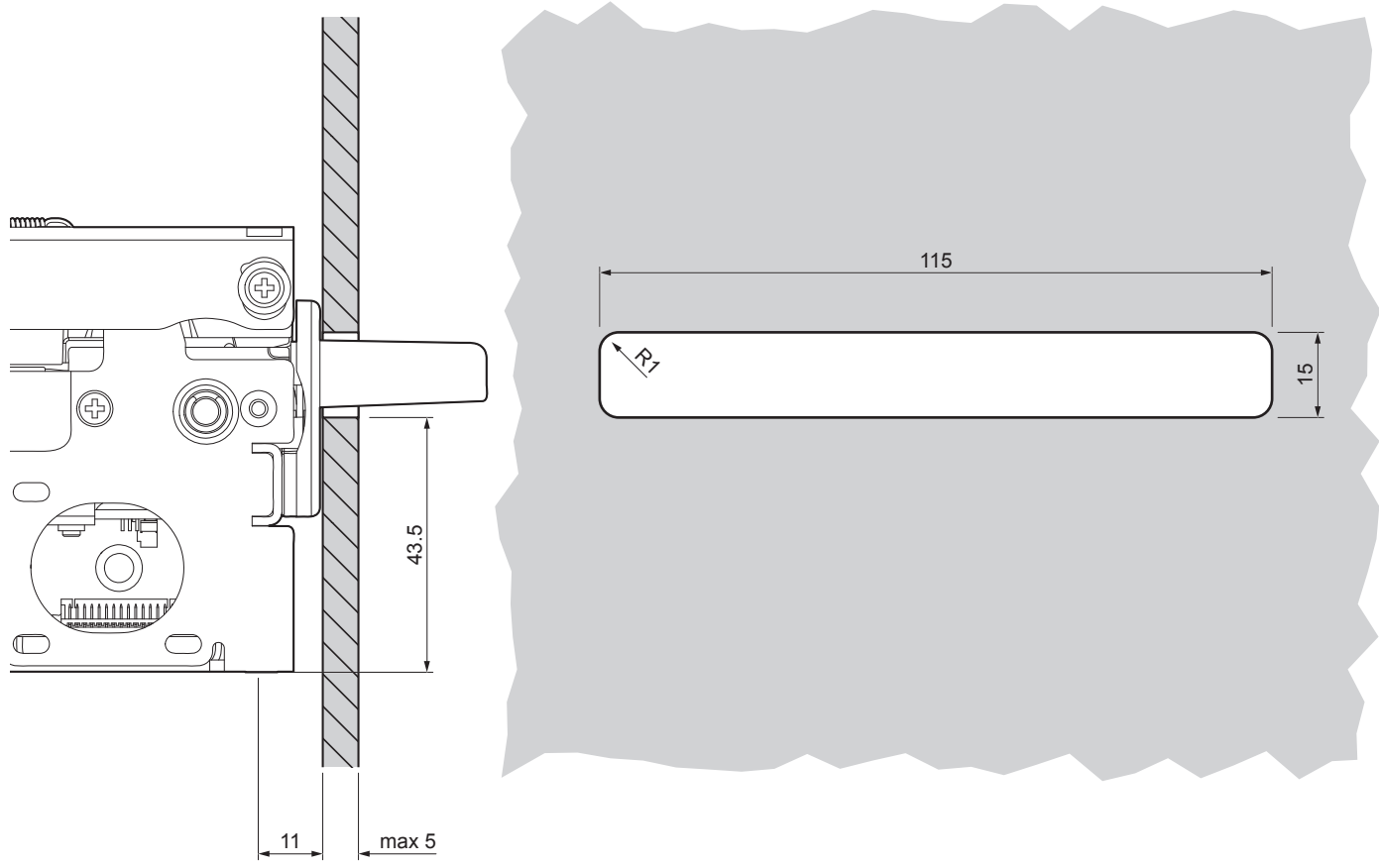

4.2 Connections

The following figure shows the possible connections for the device.

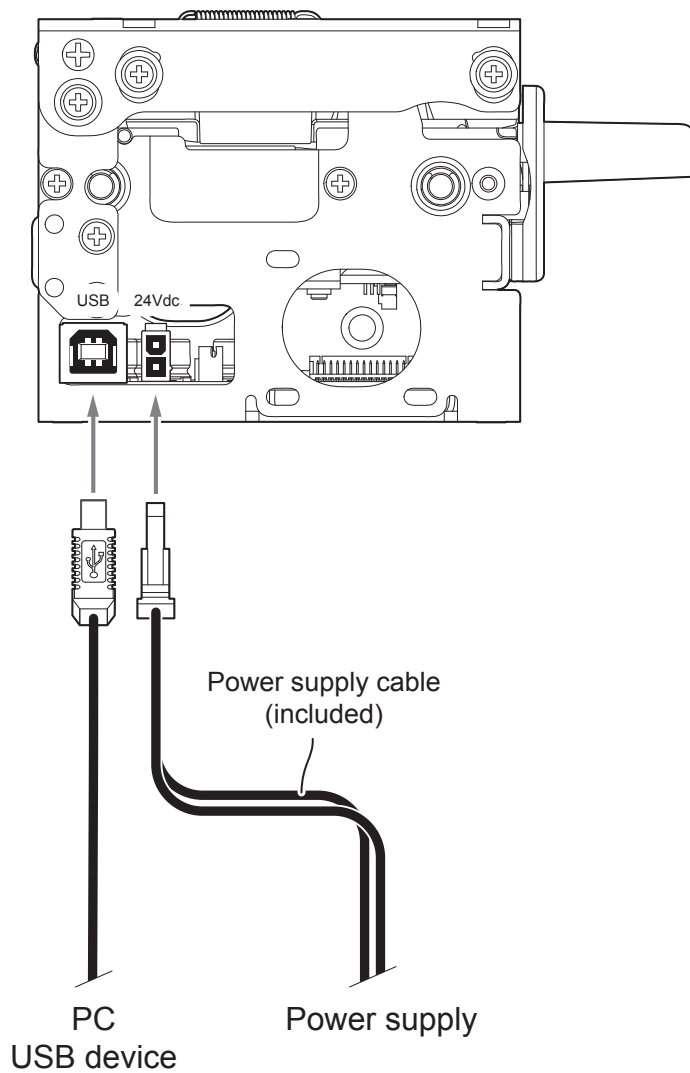

ATTENTION:

In some using conditions, we recommend the installation of a ferrite core on the power supply cable.

4.3 Pinout



POWER SUPPLY

Male Molex connector series 5569 vertical (n° 39-30-1020)

J19	1	+24 Vdc
	2	GND

The following figure shows the connector pinout of the power supply cable for the device:

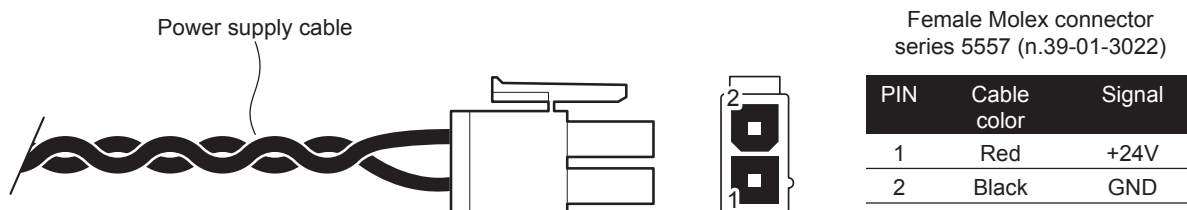

ATTENTION:
Respect power supply polarity.

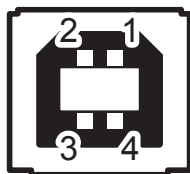

USB INTERFACE

Female USB type B connector

J3	1	USBHS_VBUS	(in)
	2	USBHS_D-	(in/out)
	3	USBHS_D+	(in/out)
	4	GND	
	SH1	SHIELD	
	SH2	SHIELD	



4.4 Driver and tools

The drivers and the tools for the following operating system are available in the website www.custom4u.it:

OPERATING SYSTEM	DESCRIPTION	INSTALLATION PROCEDURE
Windows (Win32 and .NET)	Driver for Windows 7 (32/64 bit)	Download the SDK package. Extract the zipped folder to the destination path desired. Access the "Driver" subfolder and click on the .exe file contained. The installation closes automatically at its end.
	Driver for Windows 8 (32/64 bit)	
	Driver for Windows 8.1 (32/64 bit)	
	Driver for Windows 10 (32/64 bit)	
Linux	32/64 bit	





5 OPERATION

The device is provided with two CIS sensors able to acquire images of both sides of a document. A CIS (Contact Image Sensor) sensor is an image sensor consists of RGB LEDs that turn on and off in rapid sequence illuminating the document and of a linear array of sensors that detect the variation in brightness.

The device is piloted by special libraries (see [paragraph 4.4](#)). Using such libraries it is possible for example:

- set scanning parameters
- scan a ticket or a document
- receive the image of the last scan performed
- perform a firmware upgrade
- receive information on the device status
- receive information on hardware and firmware release
- perform an hardware reset of the device
- use a demo software that exploits these libraries



SCANNER A6 MSR, SCANNER A6 MSR US

Cheques can also be read via two MICR reader for the magnetic ink character CMC-7 recognition. MICR characters are printed with a magnetic ink or toner. The magnetically charged printing allows each character to be recognized based on the magnetic signal created by each character's unique shape.

The following figure shows the correct position of a cheque when it is inserted into the device.

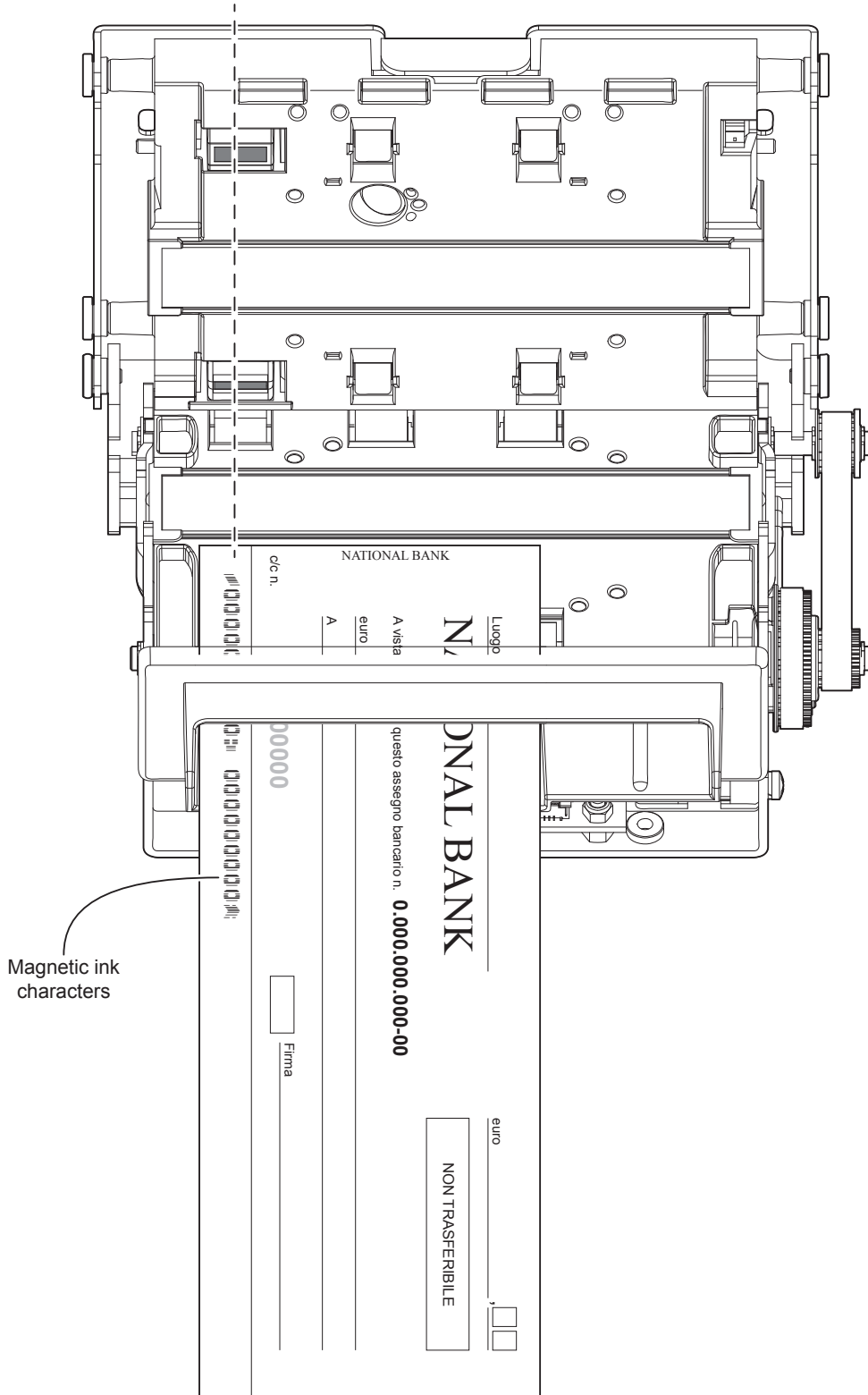

5.1 Opening the cover

1

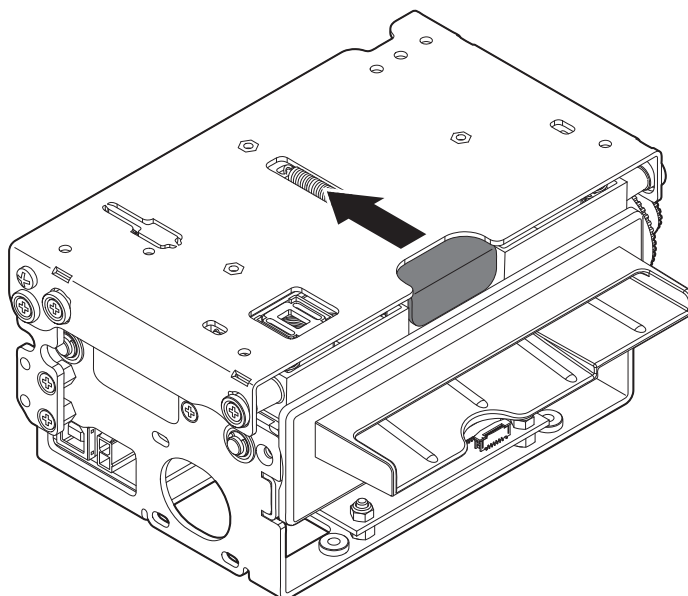

Push the release lever
in the direction shown in the figure.

2

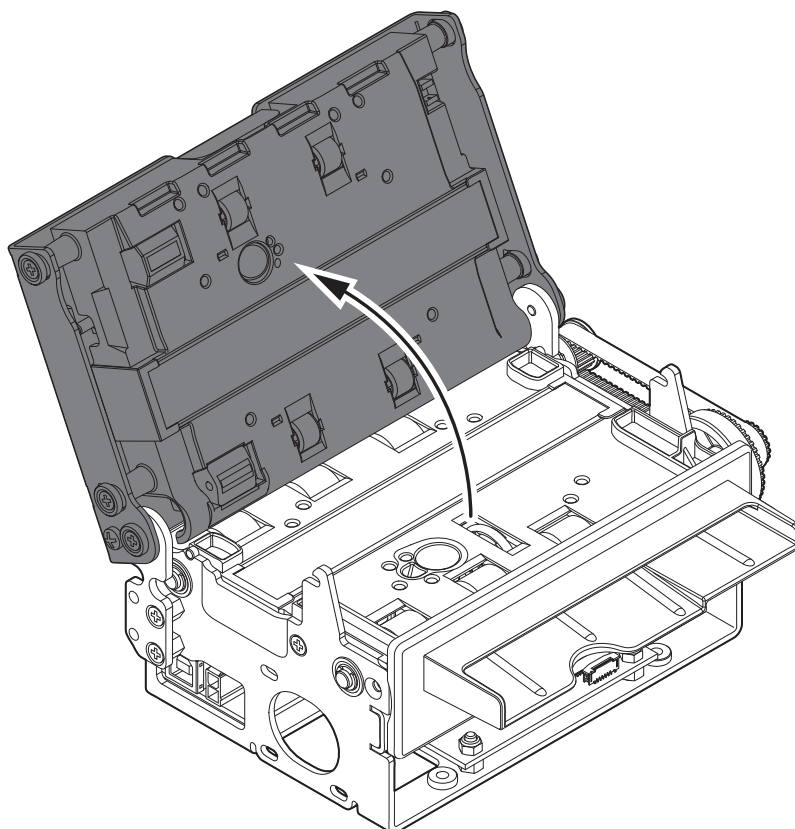

Open the device cover.

5.2 Switch the device ON/OFF

1

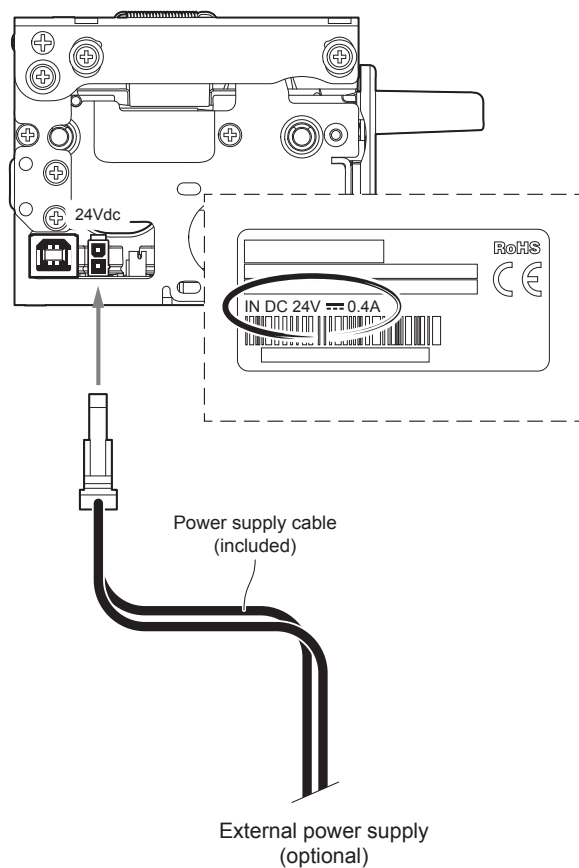

Connect the power supply cable to an external power supply unit and to the device.
Use the type of electrical power supply indicated on the label.

2

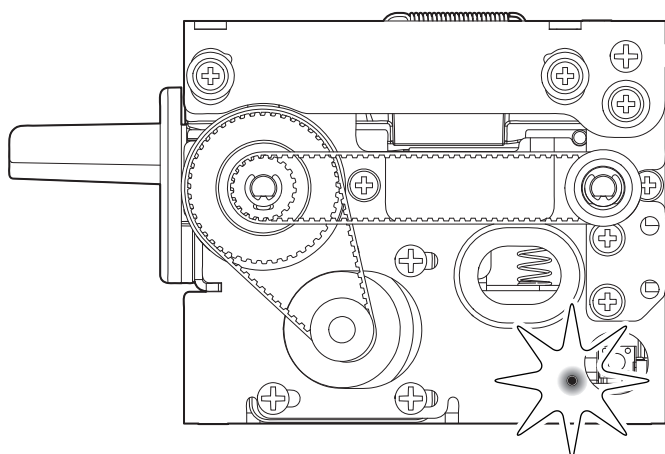

5.3 Ticket management

The device allows you to choose between different operating modes for the management of scanned documents. The operating modes shown in the following images, depend on the configuration parameters set with the libraries.

“EJECT” mode

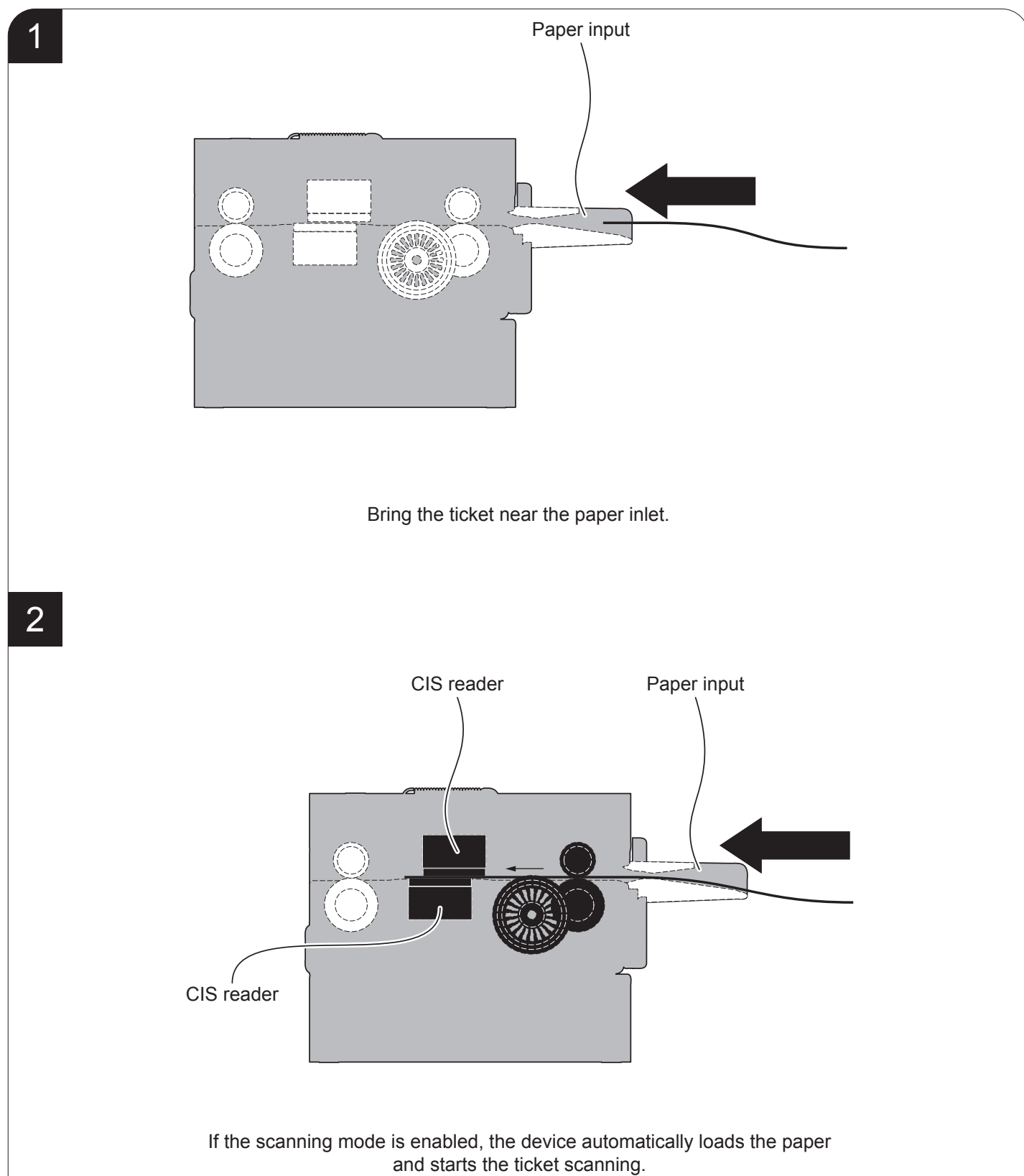

3

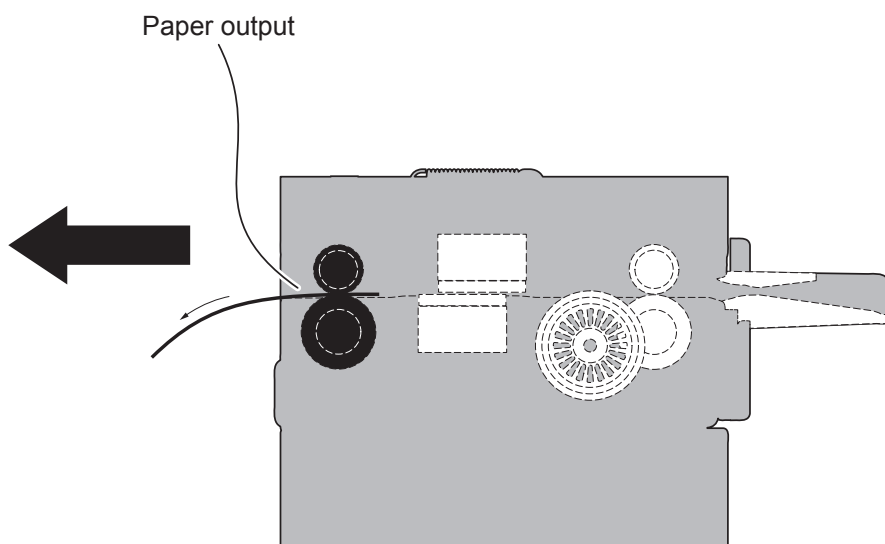

The device directly ejects the ticket.

“RETRACT” mode

1

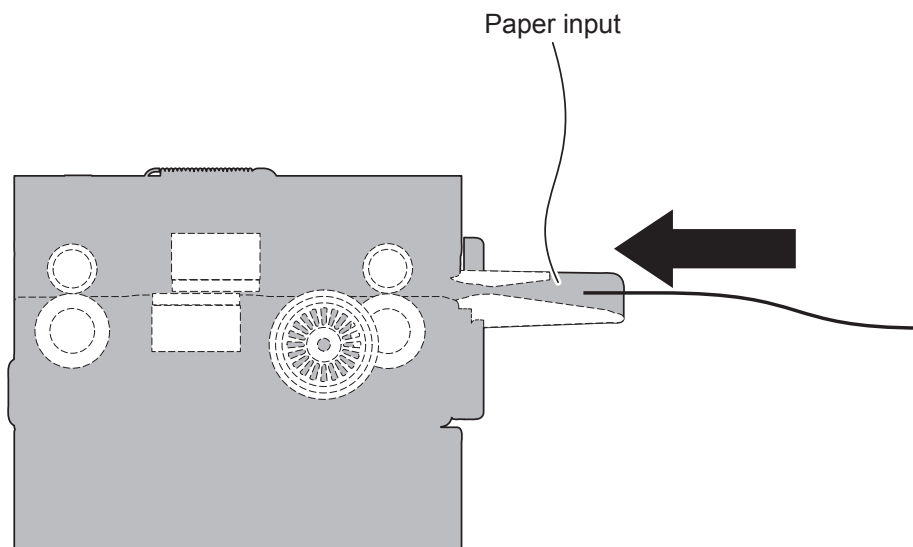

Bring the ticket near the paper inlet.

2

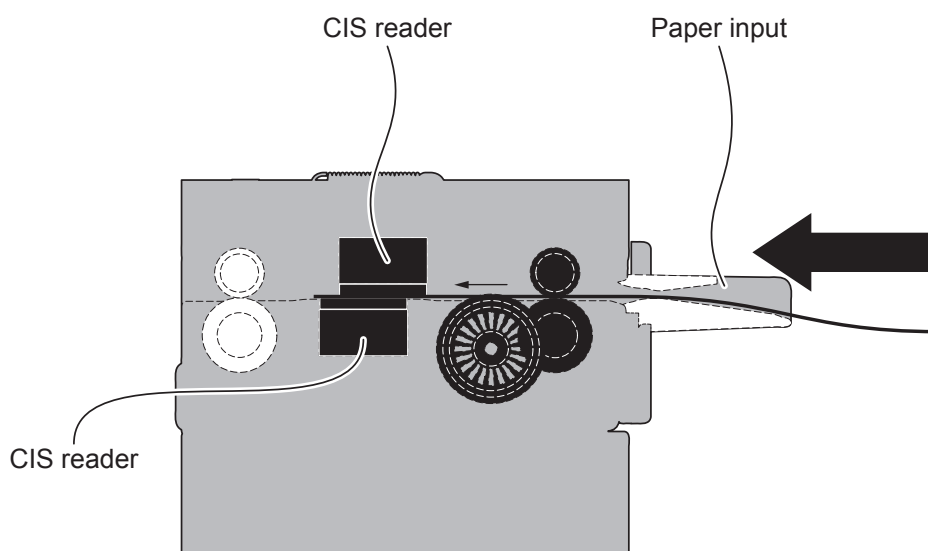

If the scanning mode is enabled, the device automatically loads the paper and starts the ticket scanning.

3

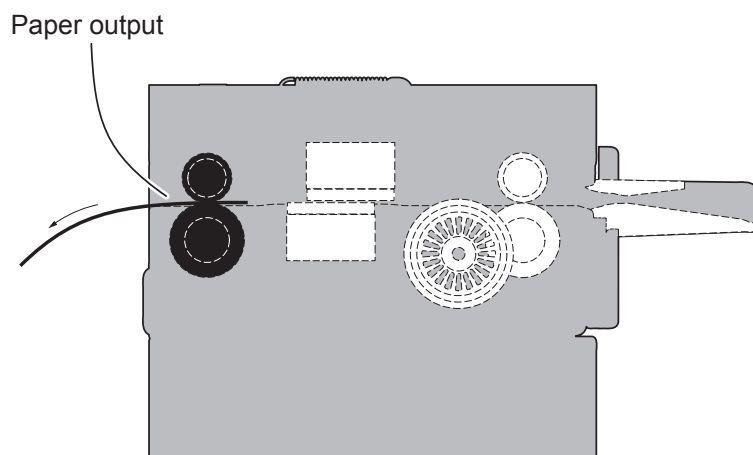

The ticket advances ahead to the paper output and is caught between the device rollers.

4

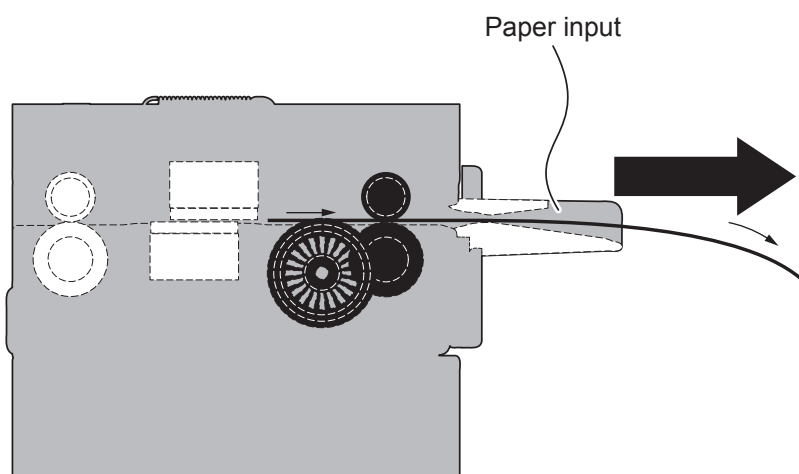

The device ejects the ticket from the paper input.

6 MAINTENANCE

6.1 Paper jam

1

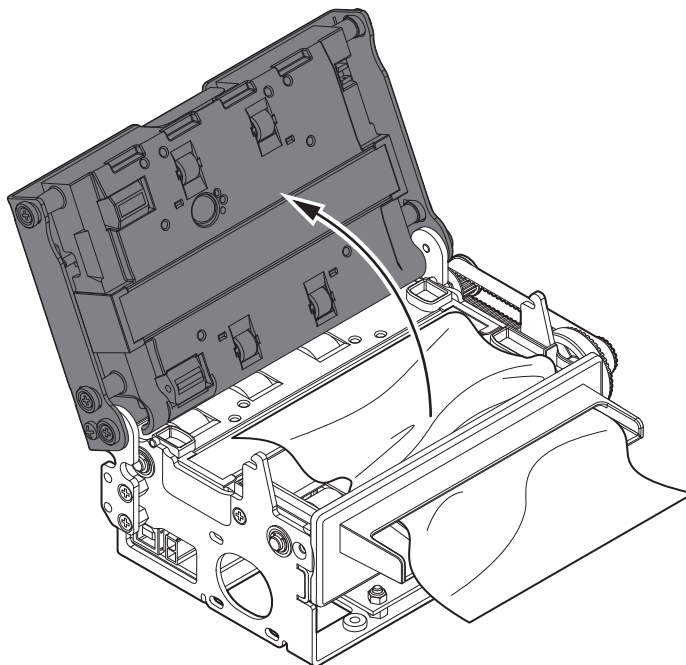

Lift the device cover (see [paragraph 5.1](#)).

2

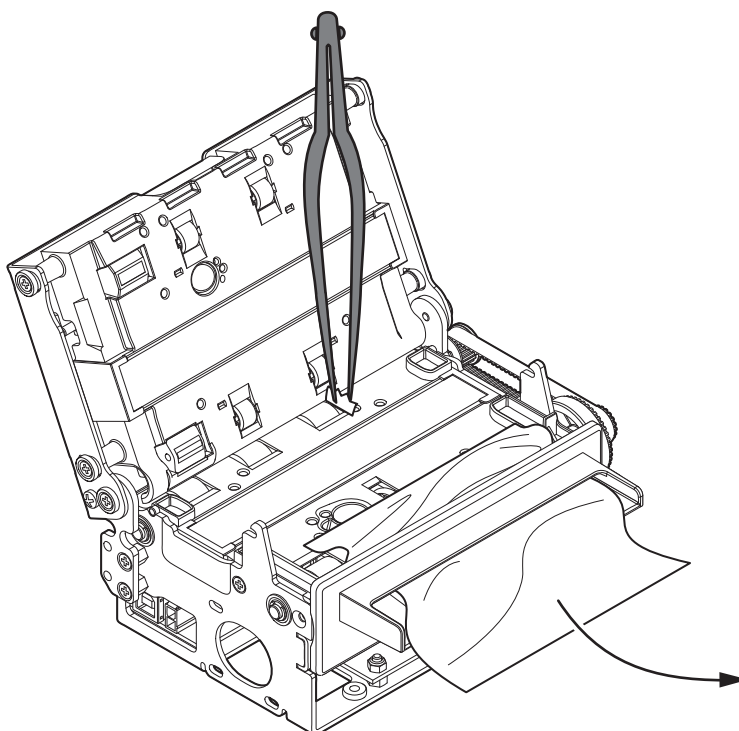

Remove the damaged paper and check the presence for paper scraps inside the device. Carefully remove all paper scraps. If necessary use tweezers.

3

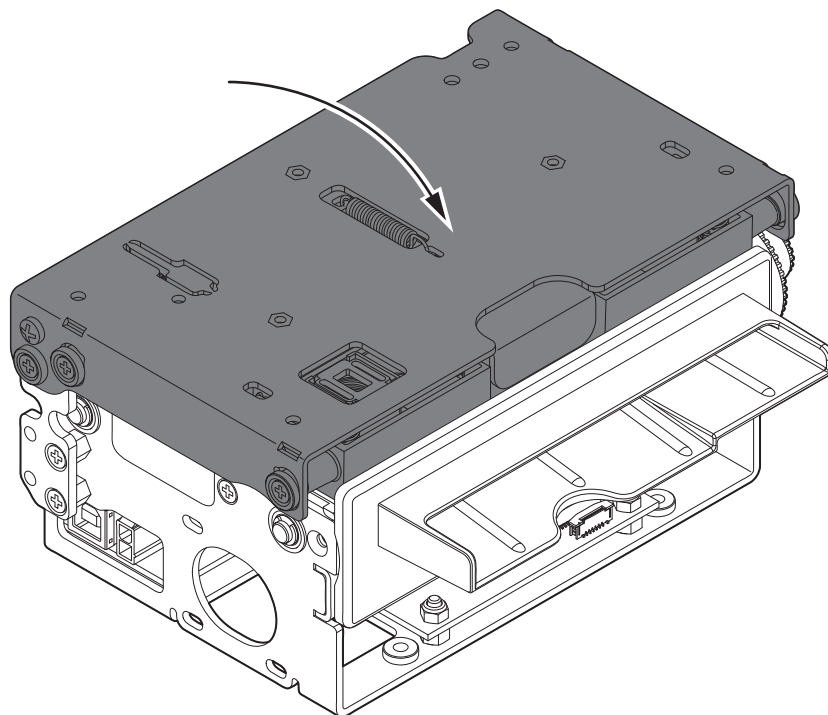

Close the device cover.

4

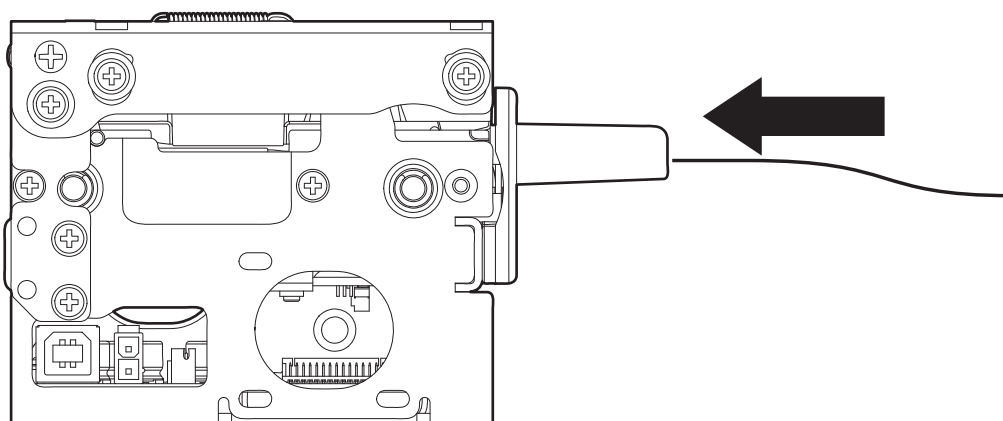

The device is ready.

6.2 Cleaning

The regular cleaning of the device keeps the scan quality and extends its life. The device does not provide a pre-established cleaning schedule. Proceed with cleaning operations when image acquisition is inaccurate. For cleaning the device, see the instructions below:

Sensors

1

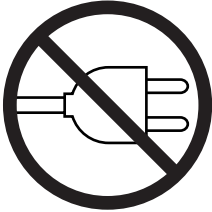

Disconnect the power supply cable and open the device cover (see [paragraph 5.1](#)).

2

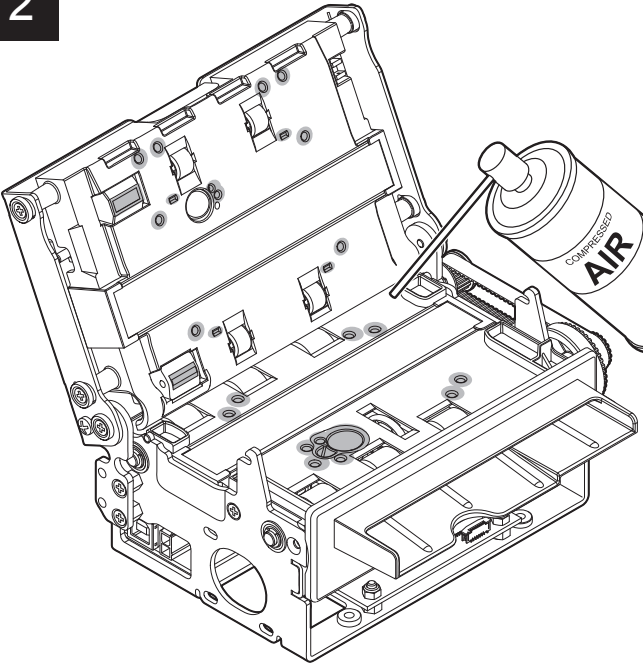

ATTENTION:
Do not use alcohol, solvents, or hard brushes.
Do not let water or other liquids get inside the machine.
To remove paper scraps, use tweezers or compressed air.



Clean the device sensors by using compressed air.

Paper path

1

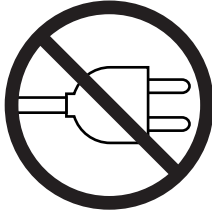

Disconnect the power supply cable and open the device cover (see [paragraph 5.1](#)).

2

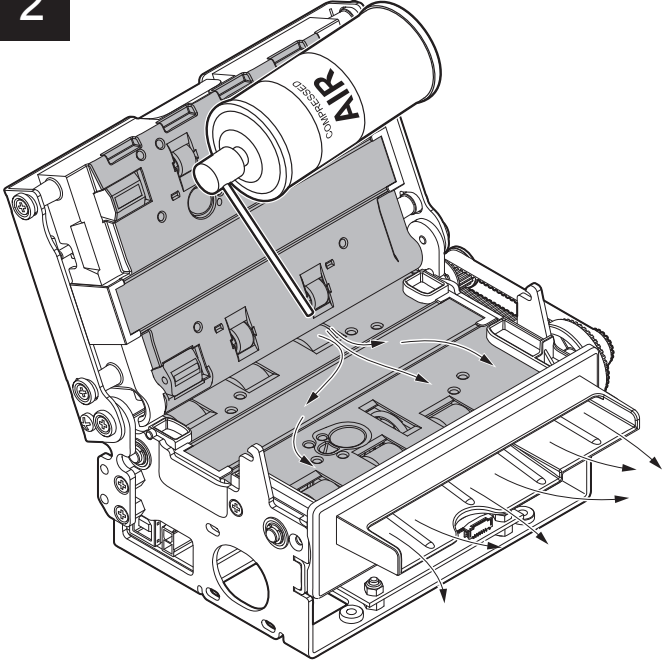

ATTENTION:
Do not use alcohol, solvents, or hard brushes.
Do not let water or other liquids get inside the machine.
To remove paper scraps, use tweezers or compressed air.



Clean, from the inside out, the area involved in the passage of paper by using compressed air.

Feed rollers

CIS readers

1

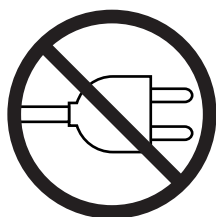

Disconnect the power supply cable and open the device cover (see [paragraph 5.1](#)).

1

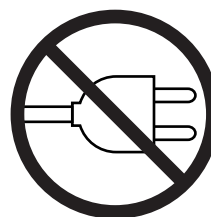

Disconnect the power supply cable and open the device cover (see [paragraph 5.1](#)).

2

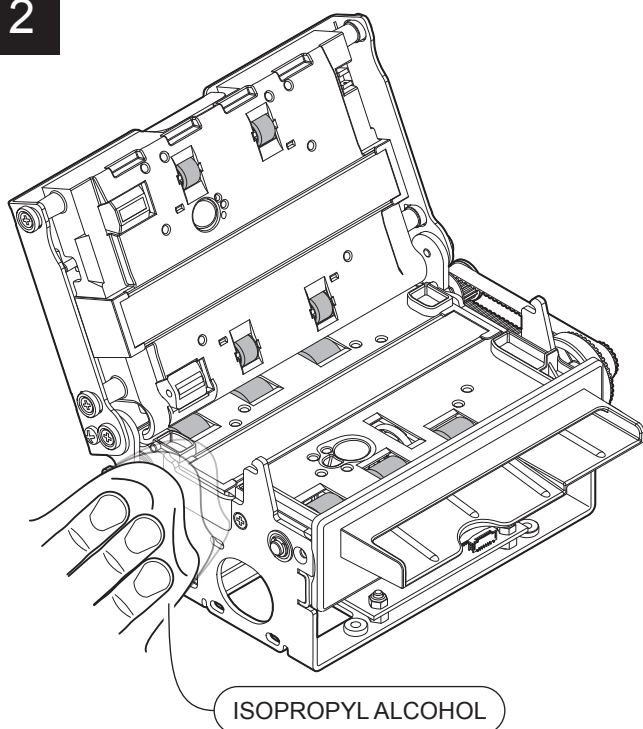

ISOPROPYL ALCOHOL

2

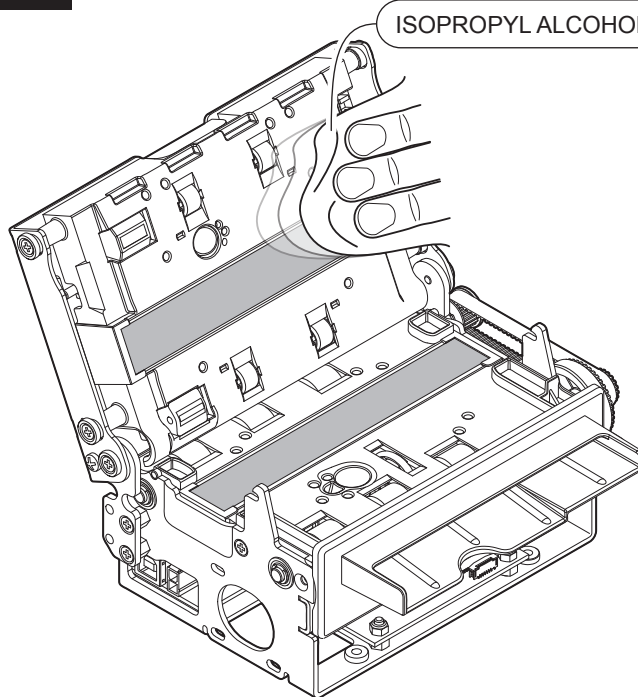

ATTENTION:

Do not use solvents, or hard brushes.
Do not let water or other liquids get inside the machine.
To remove paper scraps, use tweezers or compressed air.

ATTENTION:

Do not use solvents, or hard brushes.
Do not let water or other liquids get inside the machine.
To remove paper scraps, use tweezers or compressed air.



Clean the feed rollers by using a non-abrasive cloth moistened with isopropyl.

Clean the CIS readers by using a non-abrasive cloth moistened with isopropyl.

Device case

1

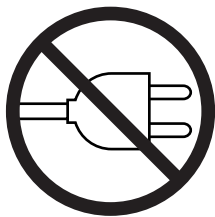

Disconnect the power supply cable.

2

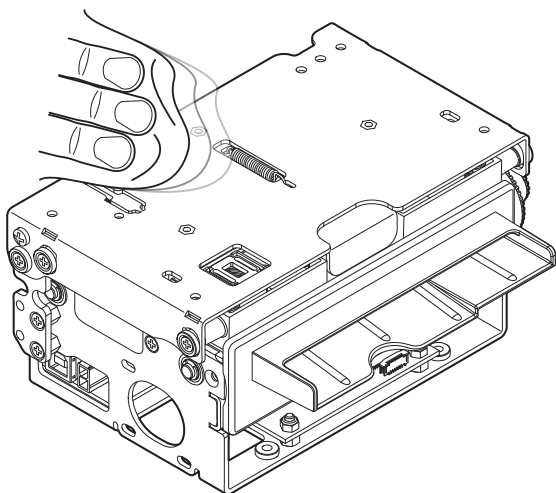

ATTENTION:

Do not use alcohol, solvents, or hard brushes.

Do not let water or other liquids get inside the machine.

To remove paper scraps, use tweezers or compressed air.



To clean the device,
use compressed air or a soft cloth.

6.3 Firmware upgrade

Firmware upgrade can be performed by using the libraries or “PrinterSet” software tool available on www.custom4u.it. To upgrade firmware by using the “PrinterSet” software tool, proceed as follows:

1

[WWW.CUSTOM4U.it](http://www.CUSTOM4U.it)

Login to the website www.custom4u.it, type in the product code of the device and download the latest firmware release available.

2

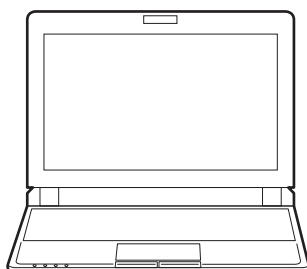

Connect the device to a PC directly (see [paragraph 4.2](#)), without using HUB devices.

3

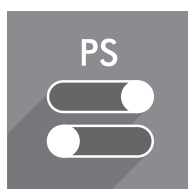

Start the “PrinterSet” software tool.

4

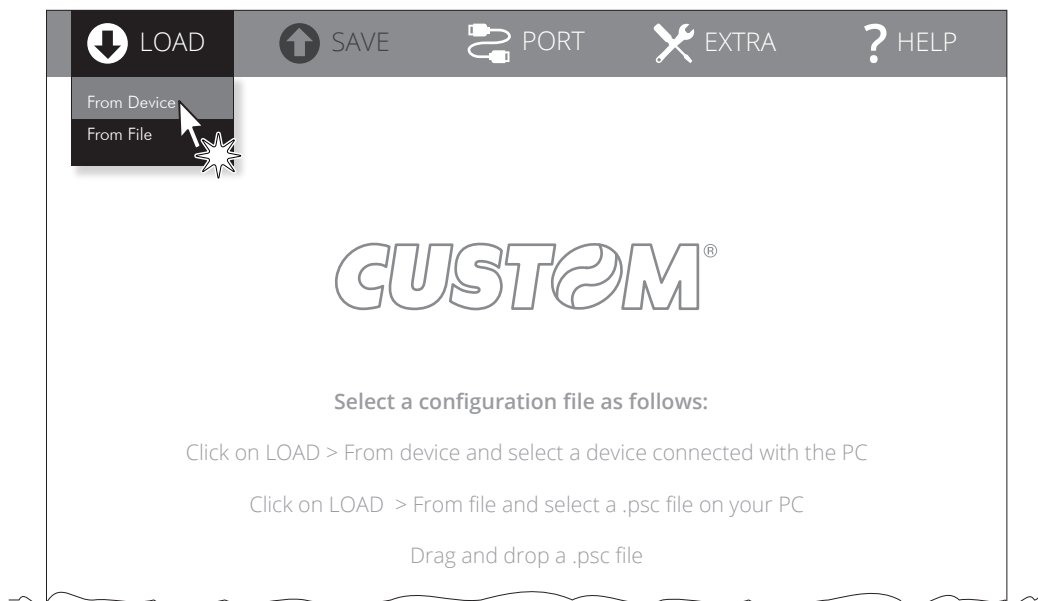

Click on LOAD > FROM DEVICE and select the device connected to the PC.

5

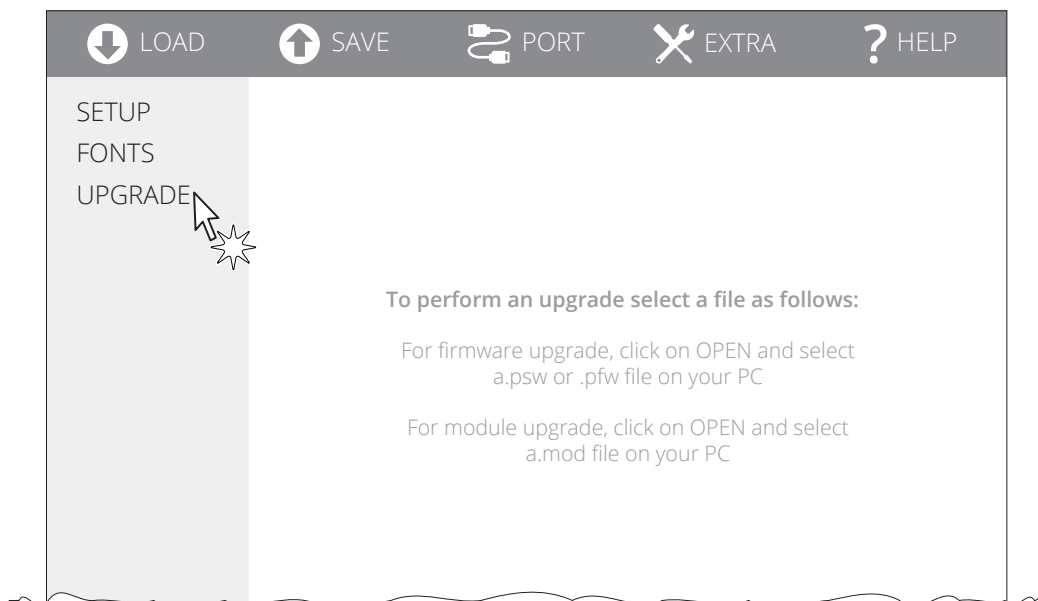

Click on UPGRADE and follow the instructions shown on the screen.

ATTENTION:

During saving, it is strongly discouraged to disconnect the communication cable or to remove the power supply of the PC or the device.





7 SPECIFICATIONS

7.1 Hardware specifications

GENERALS	
Sensors	
SCANNER A6	Paper input and output presence, paper holding, cover open, upper and lower CIS
SCANNER A6 MSR	Paper input and output presence, paper holding, cover open, upper and lower CIS, MICR reader
SCANNER A6 MSR US	Paper input and output presence, paper holding, cover open, upper and lower CIS, MICR reader, ultrasonic sheet overlap detection
Drivers	Windows 7 (32/64 bit) Windows 8 (32/64 bit) Windows 8.1 (32/64 bit) Windows 10 (32/64 bit) Linux (32/64 bit)
Windows libraries	CuDoubleSidedScannerAPI for Win32 and .NET
INTERFACES	
USB port	480 Mbit/s (USB 2.0)
MEMORIES	
Flash memory	2 MB
RAM memory	32 MB
SCANNER	
Scanner type	Contact Image Sensor (CIS)
Resolution	100 dpi, 150 dpi, 200 dpi, 250 dpi, 300 dpi
Light source	Colors LEDs: Red (635 nm) Green (525 nm) Blue (460 nm)
Scanning side and insertion direction	Two-sided



Scan modality	Black and White 8 bits greyscale 24 bits colours
---------------	--

Max. scan speed ⁽¹⁾	400 mm/s (300 dpi B/W)
--------------------------------	------------------------

Min. scan length	70 mm
------------------	-------

Max. scan length	3000 mm
------------------	---------

Max. scan width	108 mm
-----------------	--------

Image format	.bmp, .jpeg, .png, .raw, .tiff (without compression), .tiff (CCITT3 compression), .tiff (CCITT4 compression), .tiff (RLE compression), .tiff (LZW compression)
--------------	--

PAPER

Type of paper	Thermal or plain paper
---------------	------------------------

Paper width	max. 108 mm
-------------	-------------

Paper weight	from 50 g/m ² to 200 g/m ²
--------------	--

PRINTER ELECTRICAL SPECIFICATIONS

Power supply	24 Vdc ± 10% (optional external power supply)
--------------	---

Medium consumption ⁽²⁾	1 A
-----------------------------------	-----

Standby consumption	0.1 A
---------------------	-------

ELECTRICAL SPECIFICATIONS POWER SUPPLY code 963GE020000041 (optional)

Power supply voltage	from 100 Vac to 240 Vac
----------------------	-------------------------

Frequency	from 47 Hz to 63 Hz
-----------	---------------------

Output	24 V, 2.5 A
--------	-------------

Power	60 W
-------	------



ENVIRONMENTAL CONDITIONS

Operating temperature	from 0 °C to +50 °C
Relative humidity (RH)	from 0% to 80% (w/o condensation)
Storage temperature	from -20 °C to +70 °C
Storage relative humidity (RH)	from 10% to 90% (w/o condensation)

NOTE:

(1) : Respecting the regular schedule of cleaning for the device components.

(2) : Referred to the UL measurements.



7.2 Device dimensions

Length	124 mm (with cover closed) 166 mm (with cover open)
Height	76.1 mm (with cover closed) 137.5 mm (with cover open)
Width	166.5 mm
Weight	1000 g

All the dimensions shown in following figures are in millimetres.

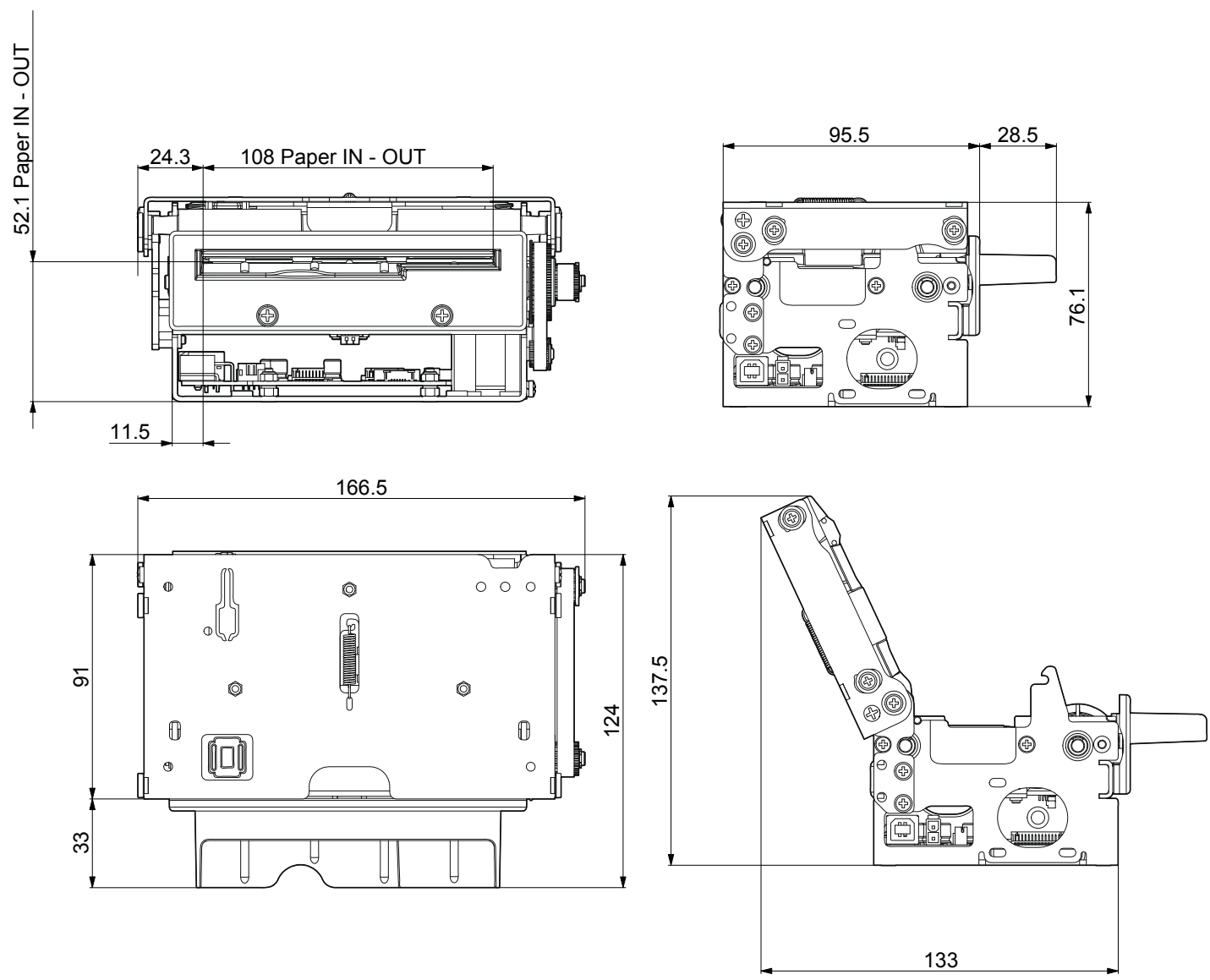

7.3 Power supply, power cord and adapter for power supply dimensions (optionals)

The following table shows the dimensions of the power supply, the power cord and the adapter for power supply optionals for the device:

POWER CORD code 26100000000311	
Length	2000 mm
ADAPTER FOR POWER SUPPLY code 26900000000005	
Length	200 mm
POWER SUPPLY code 963GE020000041	
Length	116 mm
Height	33 mm
Width	52.5 mm

All the dimensions shown in following figures are in millimetres.

POWER CORD code 26100000000311

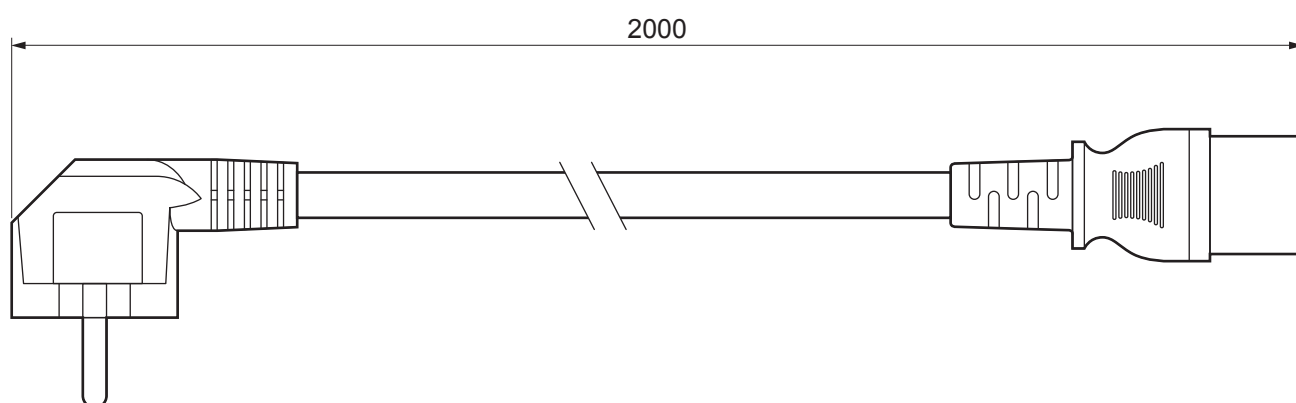



ADAPTER FOR POWER SUPPLY code 2690000000005

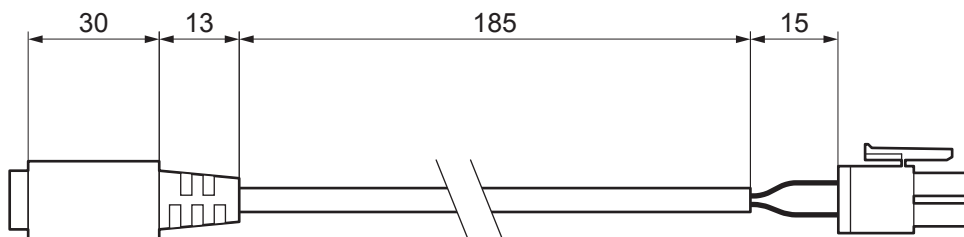

POWER SUPPLY code 963GE020000041

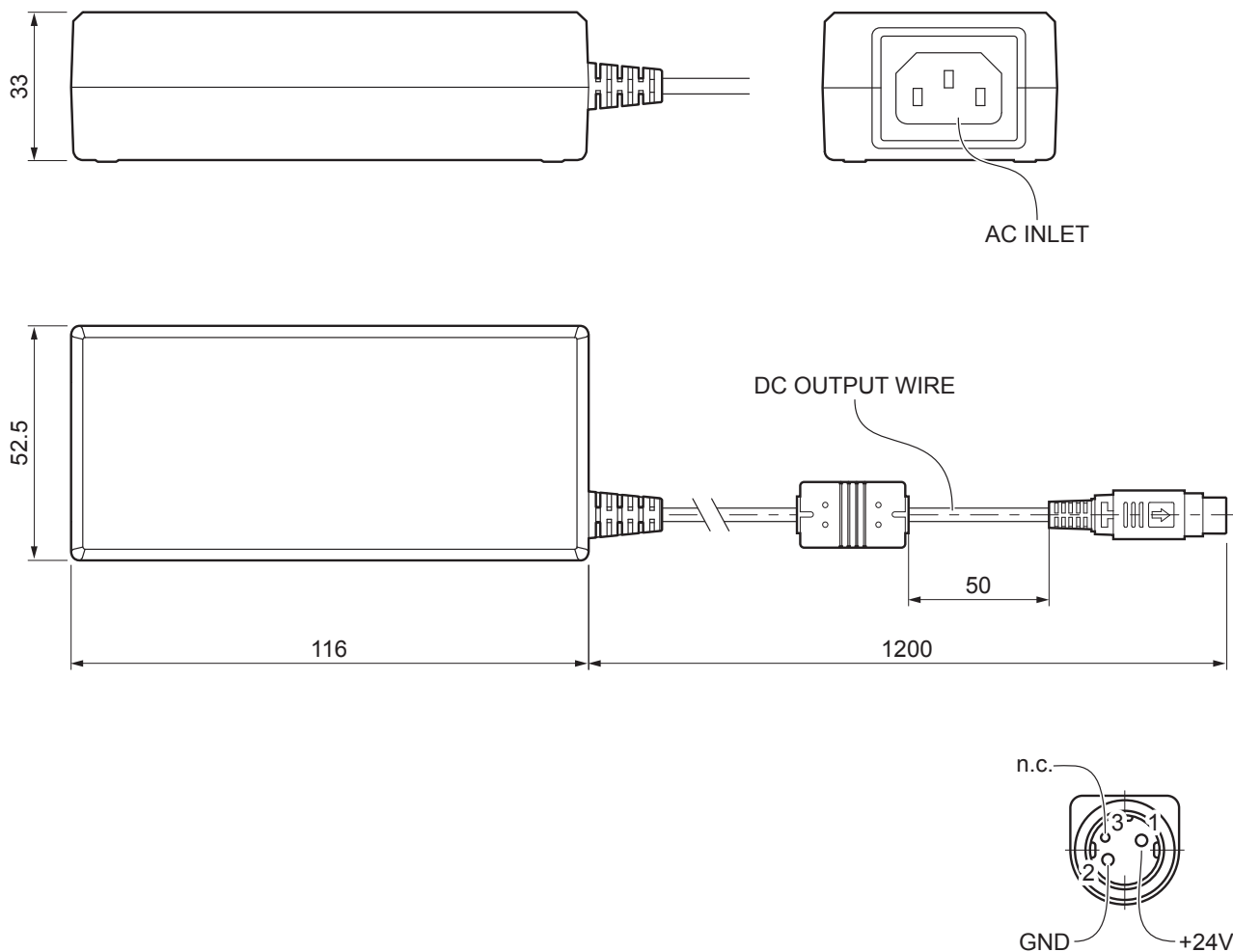

8 ACCESSORIES

The following table shows the list of available accessories for the device:

963GE020000041

POWER SUPPLY
(for technical specifications, see [paragraph 7.1](#))



26900000000005

ADAPTER CABLE FOR POWER SUPPLY
(see [paragraph 7.3](#))



261000000000311

POWER CORD SCHUKO PLUG
Length = 2 m
(see [paragraph 7.3](#))



263000000000579

POWER SUPPLY CABLE
Length = 1 m







9 TECHNICAL SERVICE

In case of failure, contact the technical service accessing the website www.custom4u.it and using the support tools on the homepage. It is advisable to keep the identification data of the product at hand.

The product code, the serial number and the hardware release number can be found on the product label (see [paragraph 3.4](#)). The firmware release number (SCODE) can be found connecting the device to a PC and using the libraries (see [chapter 5](#)) or starting the "PrinterSet" tool (see [paragraph 6.3](#)).



CUSTOM[®]

CUSTOM S.p.A.

World Headquarters

Via Berettine, 2/B - 43010 Fontevivo, Parma ITALY

Tel. +39 0521 680111 - Fax +39 0521 610701

info@custom.biz - www.custom.biz

All rights reserved

www.custom.biz