

USER MANUAL

KPM150HIII B202HIII

CUSTOM[®]

CUSTOM S.p.A.
Via Berettine 2/B
43010 Fontevivo (PARMA) - Italy
Tel. : +39 0521-680111
Fax : +39 0521-610701
http: www.custom.biz

Customer Service Department:
www.custom4u.it

© 2023 CUSTOM S.p.A. – Italy.
All rights reserved. Total or partial reproduction of this manual in whatever form, whether by printed or electronic means, is forbidden. While guaranteeing that the information contained in it has been carefully checked, CUSTOM S.p.A. and other entities utilized in the realization of this manual bear no responsibility for how the manual is used. Information regarding any errors found in it or suggestions on how it could be improved are appreciated. Since products are subject to continuous check and improvement, CUSTOM S.p.A. reserves the right to make changes in information contained in this manual without prior notification.

The pre-installed multimedia contents are protected from Copyright CUSTOM S.p.A. Other company and product names mentioned herein may be trademarks of their respective companies. Mention of third-party products is for informational purposes only and constitutes neither an endorsement nor a recommendation. CUSTOM S.p.A. assumes no responsibility with regard to the performance or use of these products.

THE IMAGES USED IN THIS MANUAL ARE USED AS AN ILLUSTRATIVE EXAMPLES. THEY COULDN'T REPRODUCE THE DESCRIBED MODEL FAITHFULLY.

UNLESS OTHERWISE SPECIFIED, THE INFORMATION GIVEN IN THIS MANUAL ARE REFERRED TO ALL MODELS IN PRODUCTION AT THE ISSUE DATE OF THIS DOCUMENT.

GENERAL INSTRUCTIONS

CUSTOM S.p.A. declines all responsibility for accidents or damage to persons or property occurring as a result of tampering, structural or functional modifications, unsuitable or incorrect installations, environments not in keeping with the equipment's protection degree or with the required temperature and humidity conditions, failure to carry out maintenance and periodical inspections and poor repair work.

GENERAL SAFETY INFORMATION

Your attention is drawn to the following actions that could compromise the characteristics of the product:

- Read and retain the instructions which follow.
- Follow all indications and instructions given on the device.
- Make sure that the surface on which the device rests is stable. If it is not, the device could fall, seriously damaging it.
- Make sure that the device rests on a hard (non-padded) surface and that there is sufficient ventilation.
- Do not fix indissolubly the device or its accessories such as power supplies unless specifically provided in this manual.
- When positioning the device, make sure cables do not get damaged.
- [Only OEM equipment] The equipment must be installed in a kiosk or system that provides mechanical, electrical and fire protection.
- The mains power supply must comply with the rules in force in the Country where you intend to install the equipment.
- Make sure that there is an easily-accessible outlet with a capacity of no less than 10A closely to where the device is to be installed.
- Make sure the power cable provided with the appliance, or that you intend to use is suitable with the wall socket available in the system.
- Make sure the electrical system that supplies power to the device is equipped with a ground wire and is protected by a differential switch.
- Before any type of work is done on the machine, disconnect the power supply.
- Use the type of electrical power supply indicated on the device label.
- These devices are intended to be powered by a separately certified power module having an SELV, non-energy hazardous output. (IEC60950-1 second edition).
- [Only POS equipment] The energy to the equipment must be provided by power supply approved by CUSTOM S.p.A.
- Take care the operating temperature range of equipment and its ancillary components.
- Do not block the ventilation openings.
- Do not insert objects inside the device as this could cause short-circuiting or damage components that could jeopardize printer functioning.
- Do not carry out repairs on the device yourself, except for the normal maintenance operations given in the user manual.
- The equipment must be accessible on these components only to trained, authorized personnel.
- Periodically perform scheduled maintenance on the device to avoid dirt build-up that could compromise the correct, safe operation of the unit.
- Do not touch the head heating line with bare hands or metal objects. Do not perform any operation inside the printer immediately after printing because the head and motor tend to become very hot.
- Use consumables approved by CUSTOM S.p.A.



THE CE MARK AFFIXED TO THE PRODUCT CERTIFY THAT THE PRODUCT SATISFIES THE BASIC SAFETY REQUIREMENTS.

The device is in conformity with the essential Electromagnetic Compatibility and Electric Safety requirements laid down in Directives 2014/30/EU and 2014/35/EU inasmuch as it was designed in conformity with the provisions laid down in the following Standards:

- EN 55032 (*Electromagnetic compatibility of multimedia equipment - Emission Requirements*)
- EN 55024/EN55035 (*Electromagnetic compatibility of multimedia equipment - Immunity requirements*)
- EN IEC/EN62368-1 (*Audio/video, information and communication technology equipment*)

The device is in conformity with the essential requirements laid down in Directives 2014/53/EU about devices equipped with intentional radiators. The Declaration of Conformity and other available certifications can be downloaded from the site www.custom4u.it.



GUIDELINES FOR THE DISPOSAL OF THE PRODUCT

The crossed-out rubbish bin logo means that used electrical and electronic products shall NOT be mixed with unsorted municipal waste. For more detailed information about recycling of this product, refer to the instructions of your country for the disposal of these products.

- Do not dispose of this equipment as miscellaneous solid municipal waste, but arrange to have it collected separately.
- The re-use or correct recycling of the electronic and electrical equipment (EEE) is important in order to protect the environment and the wellbeing of humans.
- In accordance with European Directive WEEE 2012/19/EU, special collection points are available to which to deliver waste electrical and electronic equipment and the equipment can also be handed over to a distributor at the moment of purchasing a new equivalent type.
- The public administration and producers of electrical and electronic equipment are involved in facilitating the processes of the re-use and recovery of waste electrical and electronic equipment through the organisation of collection activities and the use of appropriate planning arrangements.
- Unauthorised disposal of waste electrical and electronic equipment is punishable by law with the appropriate penalties.
- For the waste sorting of the packaging materials, please check the local waste disposal laws.



The format used for this manual improves use of natural resources reducing the quantity of necessary paper to print this copy.



FCC STATEMENT
(FEDERAL COMMUNICATIONS
COMMISSIONS).

This note is valid only for device bringing FCC trademark.

This device complies with Part 15 of the FCC Rules. Operation is subject to the following conditions:

The devices may not cause harmful interference.
The devices must accept any interference received, including interference that may cause undesired operation.

NOTE: This equipment has been tested and found to comply with the limits for a Class B digital device, pursuant to Part 15 of the FCC Rules. These limits are designed to provide reasonable protection against harmful interference in a residential installation. This equipment generates, uses and can radiate radio frequency energy and, if not installed and used in accordance with the instructions, may cause harmful interference to radio communications. However, there is no guarantee that interference will not occur in a particular installation. If this equipment does cause harmful interference to radio or television reception, which can be determined by turning the equipment off and on, the user is encouraged to try and correct the interference by one or more of the following measures:

Reorient or relocate the receiving antenna.
Increase the separation between the equipment and receiver.
Connect the equipment into an outlet on a circuit different from that to which the receiver is connected.
Consult the dealer or an experienced radio/TV technician for help.

Modifications to this product not authorized by CUSTOM S.p.A. could void the FCC & Industry Canada regulations and negate your authority to operate the product.

This Class B digital apparatus complies with Canadian ICES-003.
Cet appareil numérique de la classe B est conforme à la norme NMB-003 du Canada.

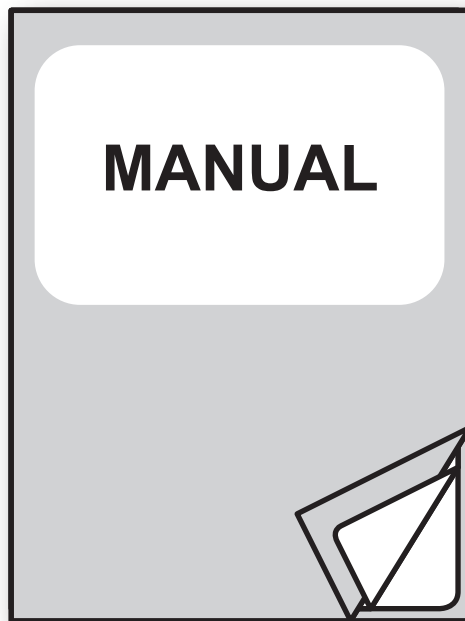

For details on the commands,
refer to the manual with code **77200000004600**

For further information about the use of “PrinterSet” tool
refer to the manual with code **78200000001800**

TABLE OF CONTENTS

1	INTRODUCTION	9
2	IDENTIFICATION OF THE MODELS	11
3	DESCRIPTION	13
3.1	Box contents	13
3.2	Device components: external views	15
3.3	Connectors panel	17
3.4	Device components: internal views	19
3.5	Product label	20
3.6	Key functions: power up	21
3.7	Key functions: standby	22
3.8	Status messages	23
4	INSTALLATION	25
4.1	Fixing	25
4.2	Additional low paper sensor	26
4.3	Connections	30
4.4	Pinout	32
4.5	Driver and SDK	36
5	OPERATION	37
5.1	Opening device cover	37
5.2	Adjusting paper width	38
5.3	Adjusting the alignment sensors	39
5.4	Switch the device on	42
5.5	Loading the paper roll	44

6	CONFIGURATION	51
6.1	Configuration by keys	51
6.2	Configuration by software	54
6.3	Configuration by file	55
6.4	Printhead status	57
6.5	Device status	58
6.6	Communication parameters	59
6.7	Operation parameters	61
6.8	Alignment parameters	64
6.9	Hexadecimal dump	66
6.10	Calendar clock	67
7	ALIGNMENT	69
7.1	Enable alignment	70
7.2	Calibration	75
7.3	Alignment parameters	78
7.4	Printing area	82
8	MAINTENANCE	83
8.1	Printer paper jam	83
8.2	Planning of cleaning operations	84
8.3	Cleaning	85
8.4	Upgrade firmware	88
9	SPECIFICATION	89
9.1	Hardware specifications	89
9.2	Character specifications	93
9.3	Device dimensions	94
9.4	Device dimensions with cut/hold kit	96
9.5	Device dimensions with ejecter / retention ticket plastic kit	97
9.6	Device dimensions with paper roll holder	98
9.7	Device dimensions with metallic ticket tray	99
9.8	Dimensions of power supply, power cord and adapter cable	100
9.9	Paper specification	102
9.10	Character sets in CUSTOM/POS emulation	106
9.11	Character sets in SVELTA emulation	108
10	CONSUMABLES	109
11	ACCESSORIES	111
11.1	Adapter cable for power supply	114
12	TECHNICAL SERVICE	115



1 INTRODUCTION

This document is divided into sections and chapters. Each chapter can be reached by the index at the beginning of this document. The index can be reached by the button on each page as shown in the diagram below.

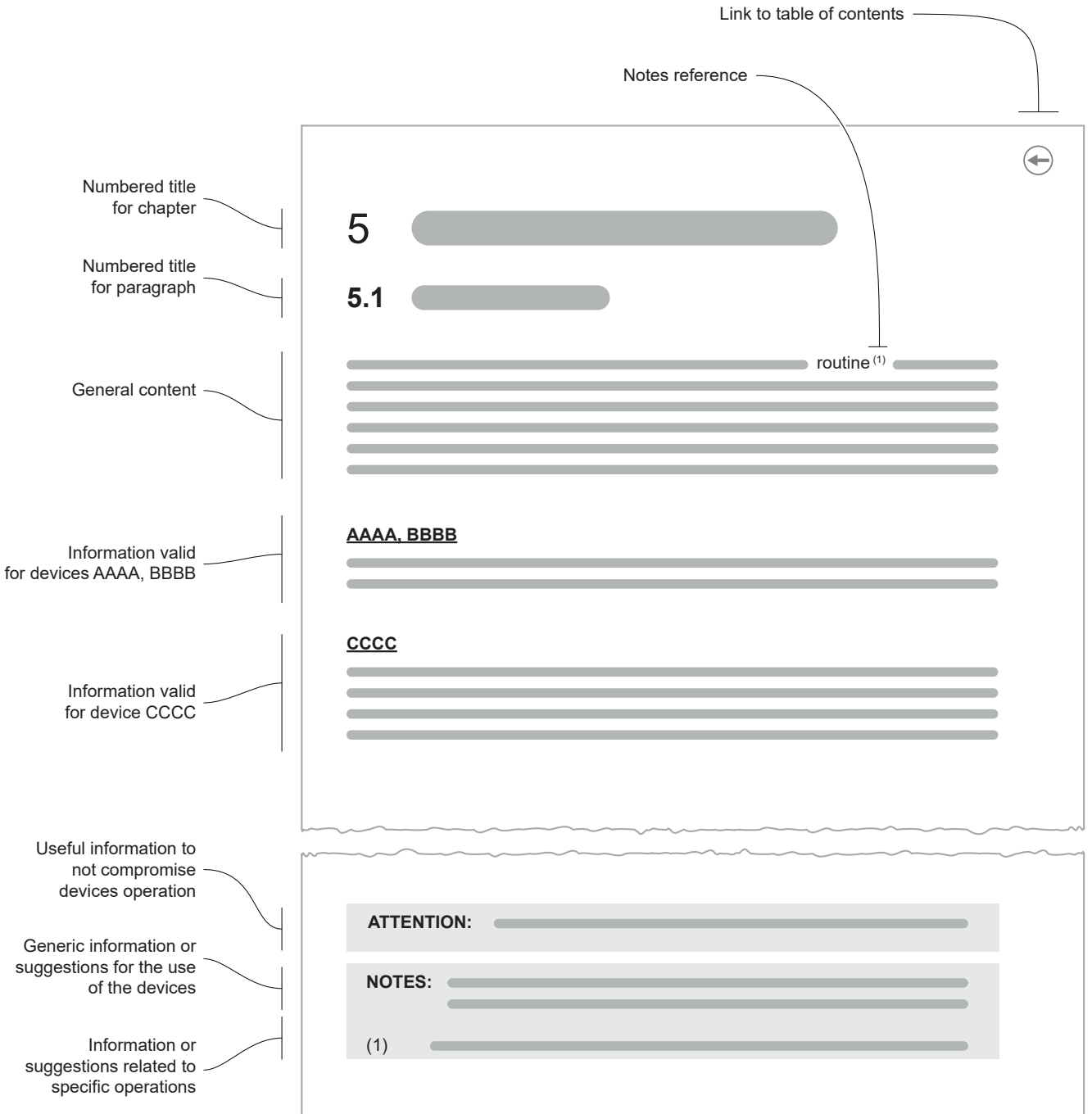





2 IDENTIFICATION OF THE MODELS

NOMENCLATURE	DESCRIPTION
KPM150HIII	KPM150HIII base configuration (OEM model with lateral connectors)
B202HIII	B202HIII base configuration (TKT model)





3 DESCRIPTION

3.1 Box contents

Remove all the box contents (see following figures) being careful not to damage the packing material so that it may be reused if the device is to be transported in the future.

Make sure that all the components illustrated below are present and that there are no signs of damage. If there are, contact Customer Service.

KPM150HIII.

1. Installation instruction sheet
2. Adapter cable for power supply
3. Additional low paper sensor with cable
4. Device

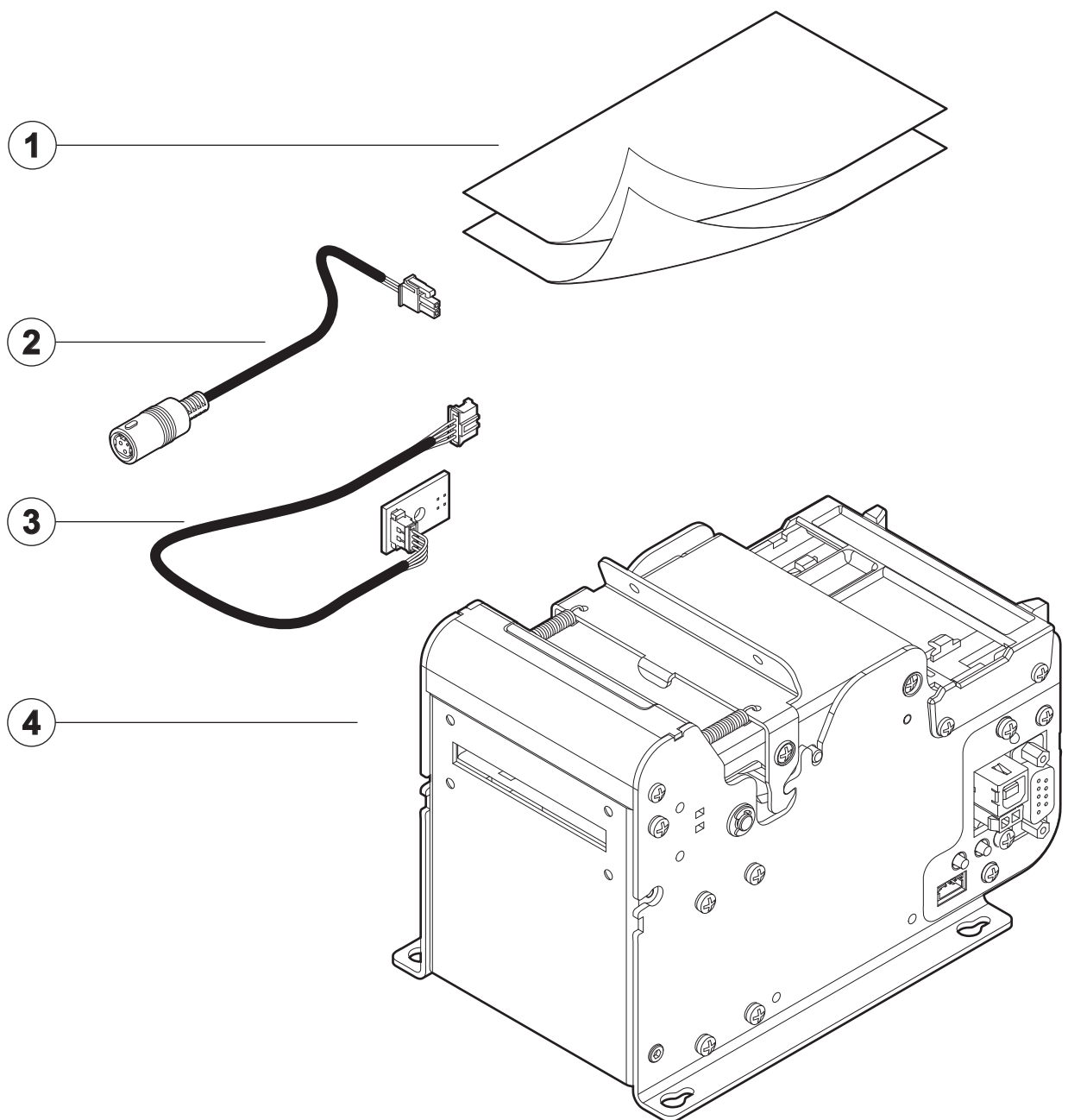



B202HIII

1. Short guide
2. AC Power supply
3. AC power cord
4. Device
5. USB cable

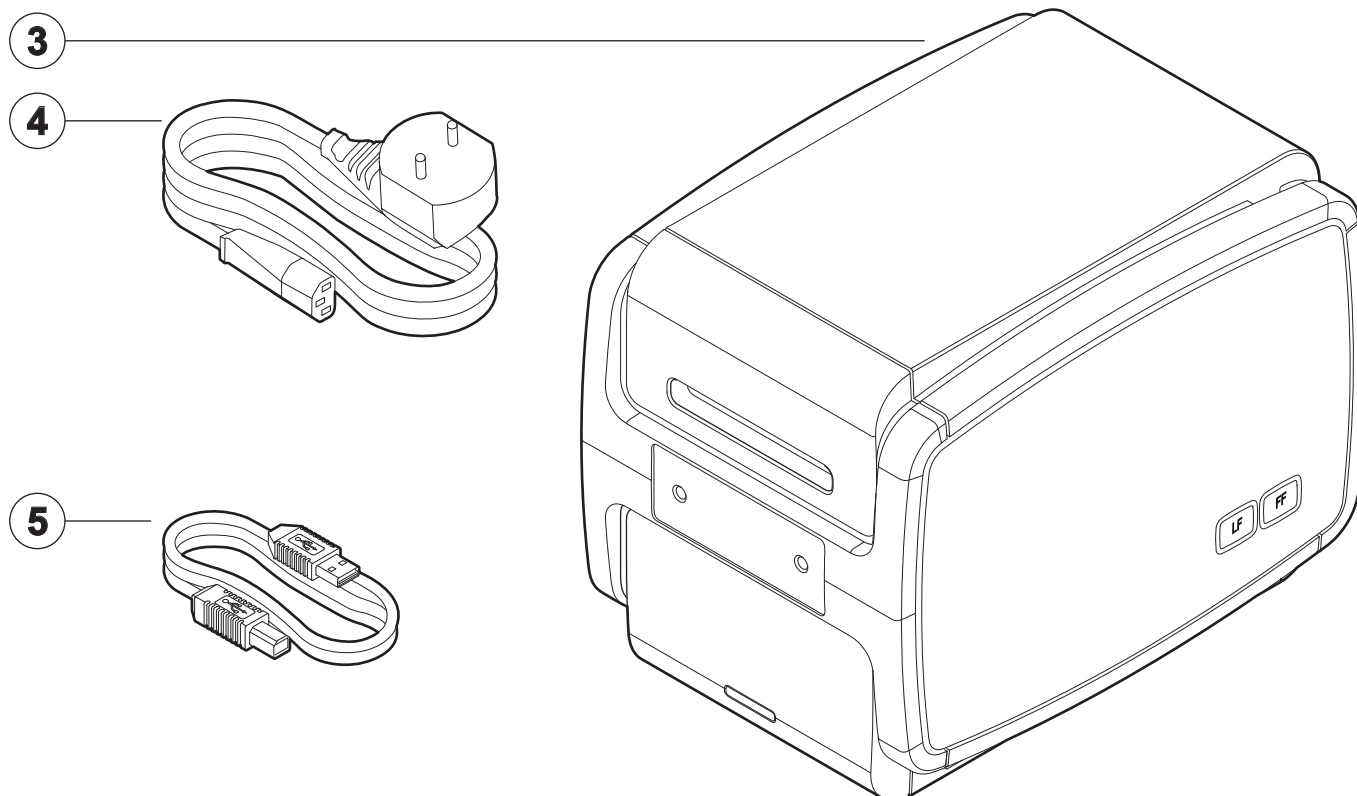
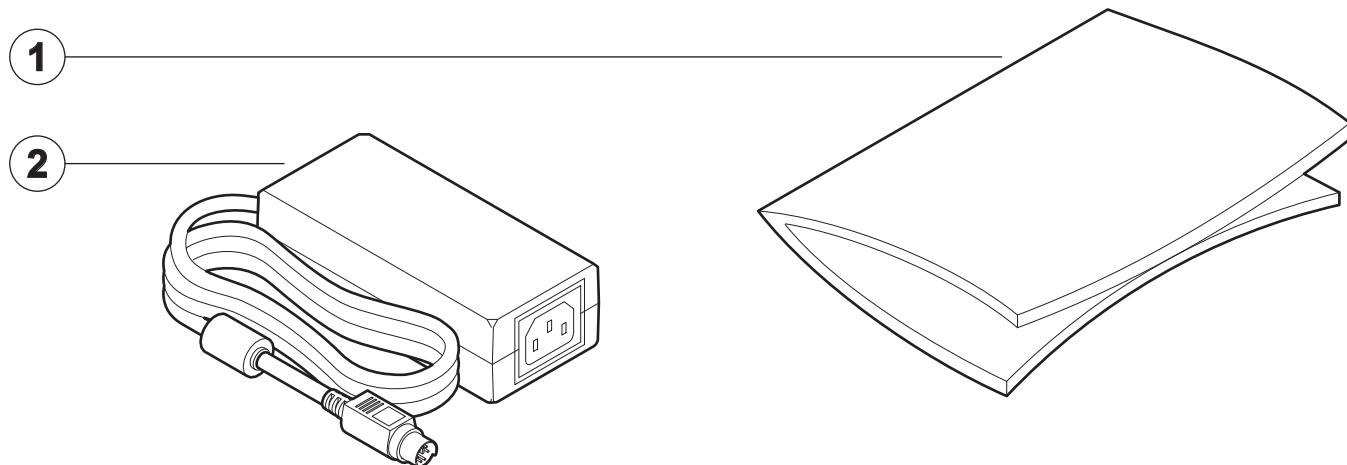

3.2 Device components: external views

KPM150HIII

- | | |
|--|---|
| 1. Printhead group | 5. Connector panel (see paragraph 3.3) |
| 2. Device cover | 6. Paper out |
| 3. Lever of paper mouth guide (adjustable) | 7. Product label (see paragraph 3.5) |
| 4. Paper input | |

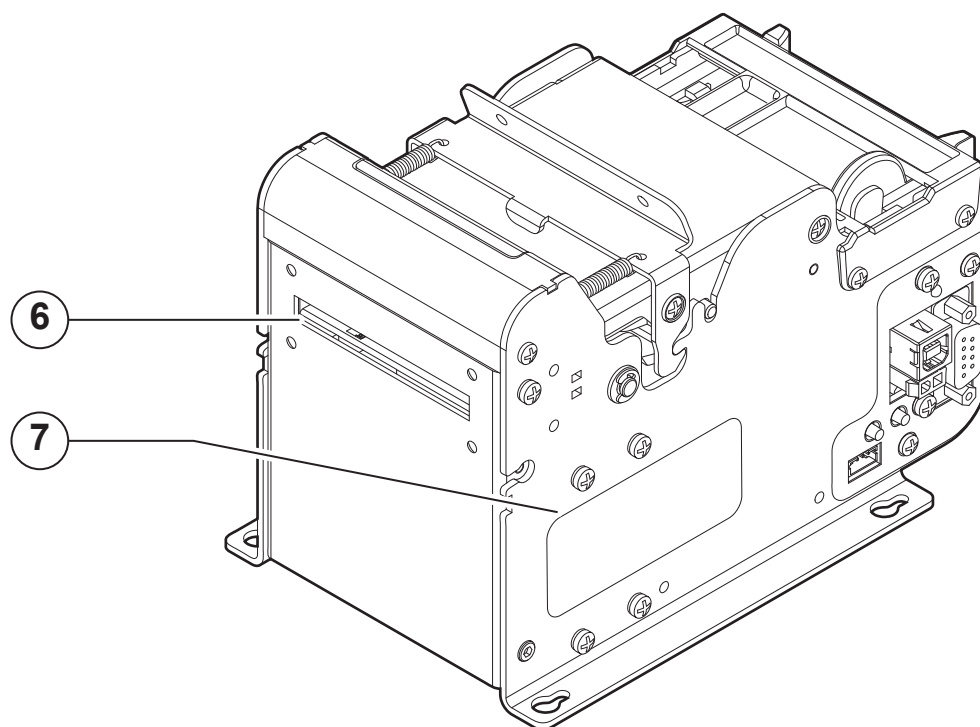
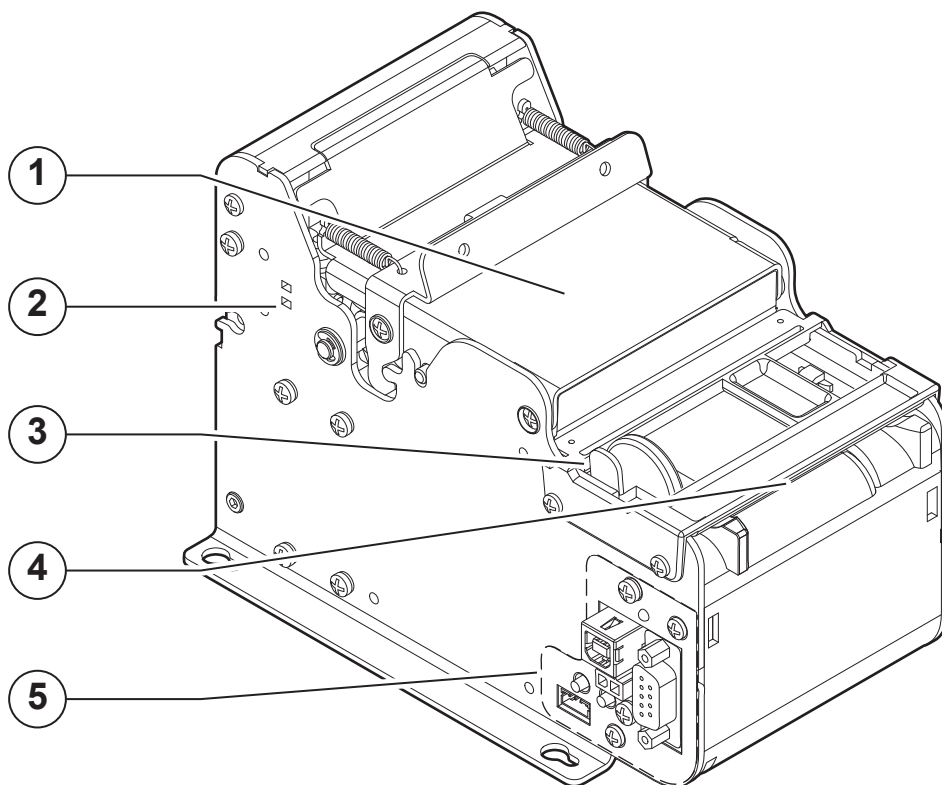



B202HIII

1. Device cover
2. Paper output
3. Status LED
4. Paper input
5. FORM FEED key
6. LINE FEED key
7. ON/OFF key
8. Connector panel (see [paragraph 3.3](#))
9. Product label (see [paragraph 3.5](#))

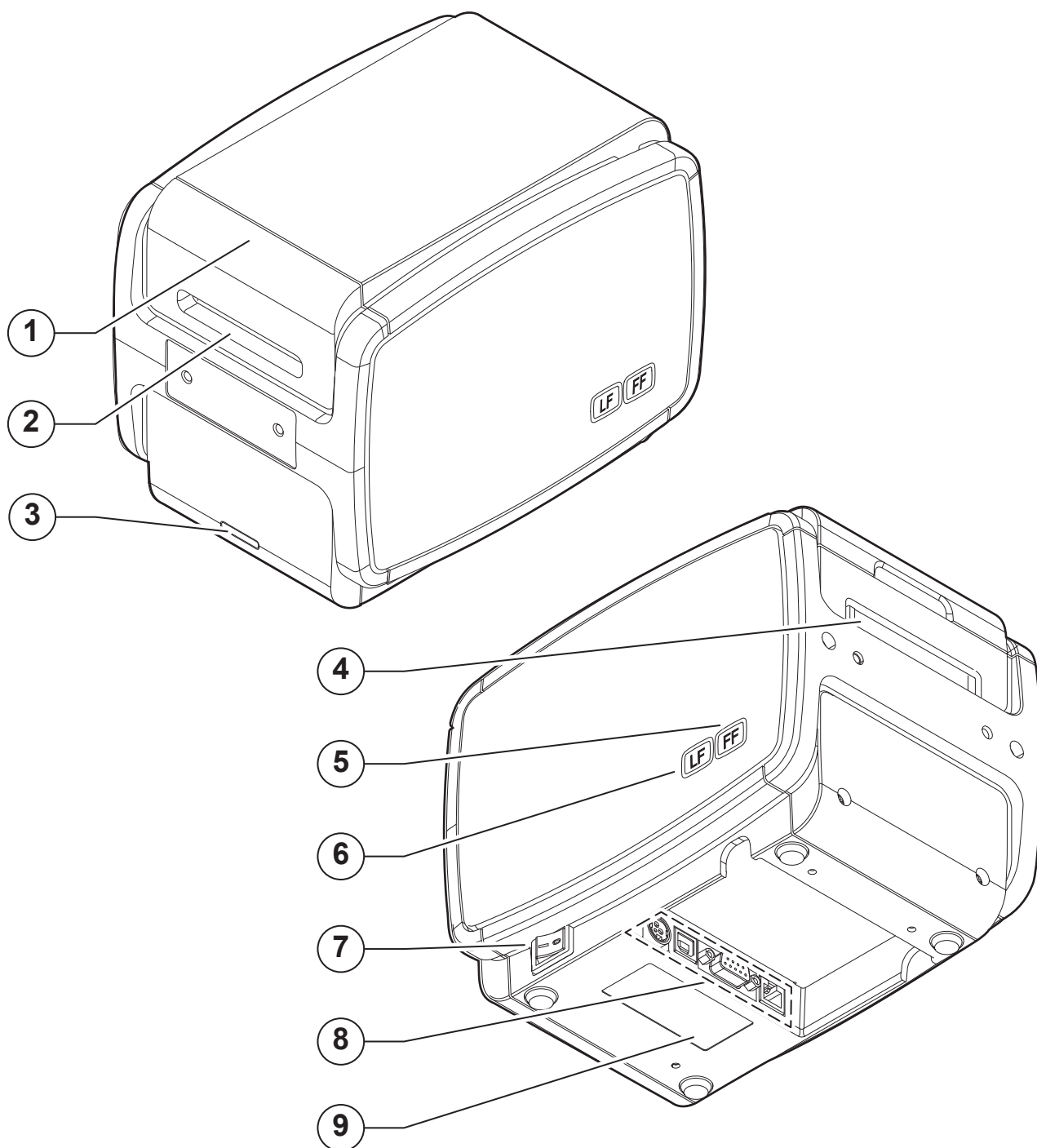

3.3 Connectors panel

KPM150HIII

1. Status LED
2. USB port
3. Power supply port
4. LINE FEED key
5. SD/MMC (optional)
6. External near end of paper sensor port
7. FORM FEED key
8. RS232 serial port

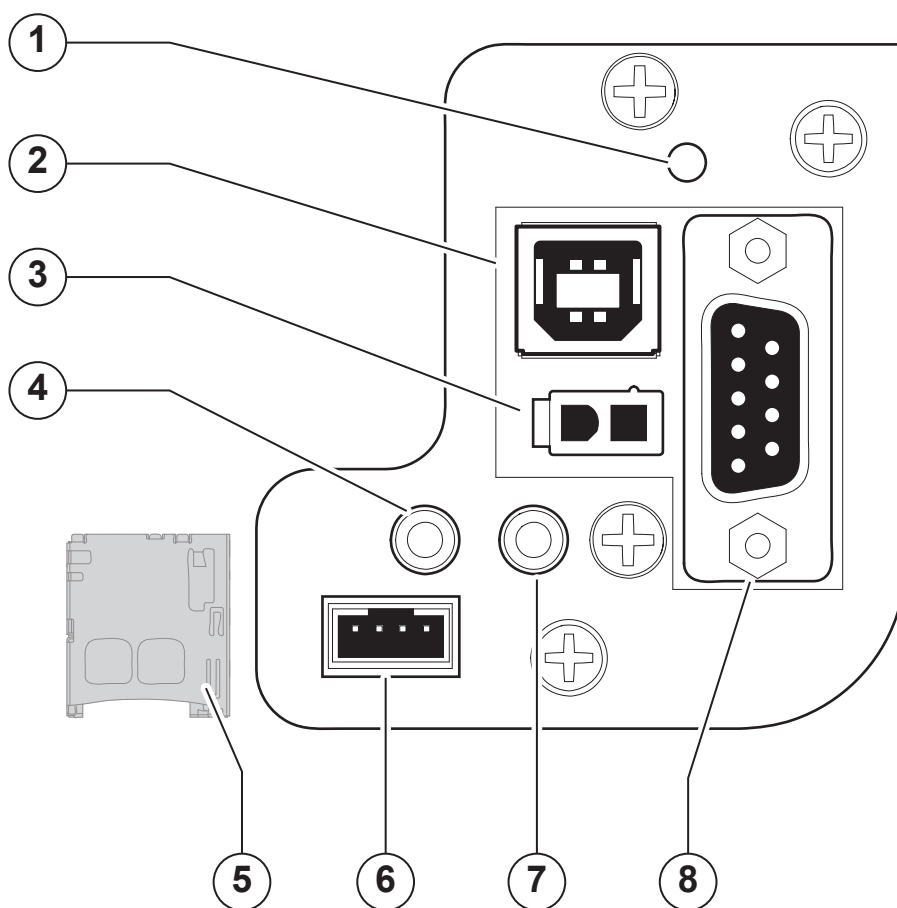



B202HIII

1. Power supply port
2. USB port
3. RS232 serial port
4. External near end of paper sensor port

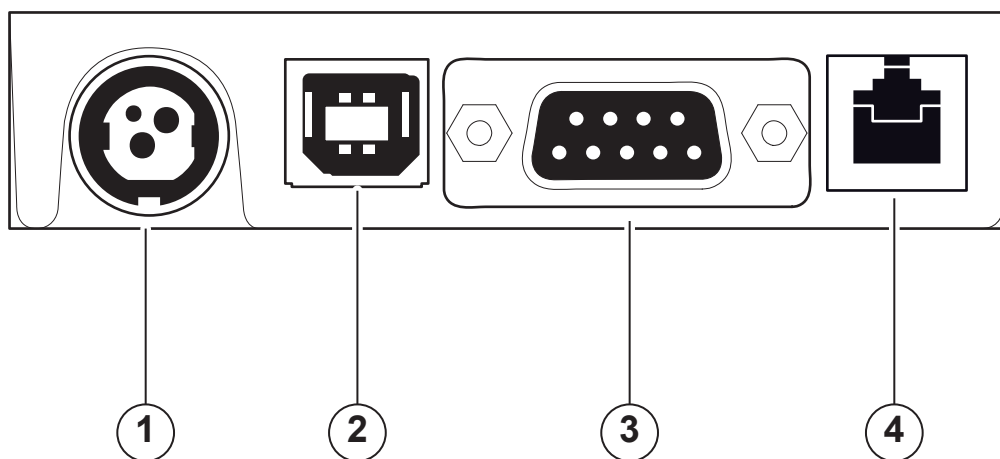

3.4 Device components: internal views

For ease of reference, for some models is represented only the internal printer group without the external plastic chassis.

1. Head temperature sensor
2. Sensor for top black mark
3. Sensors of paper presence
4. Cover open sensor
5. Mobile sensor for bottom black mark
6. Paper presence sensors in output

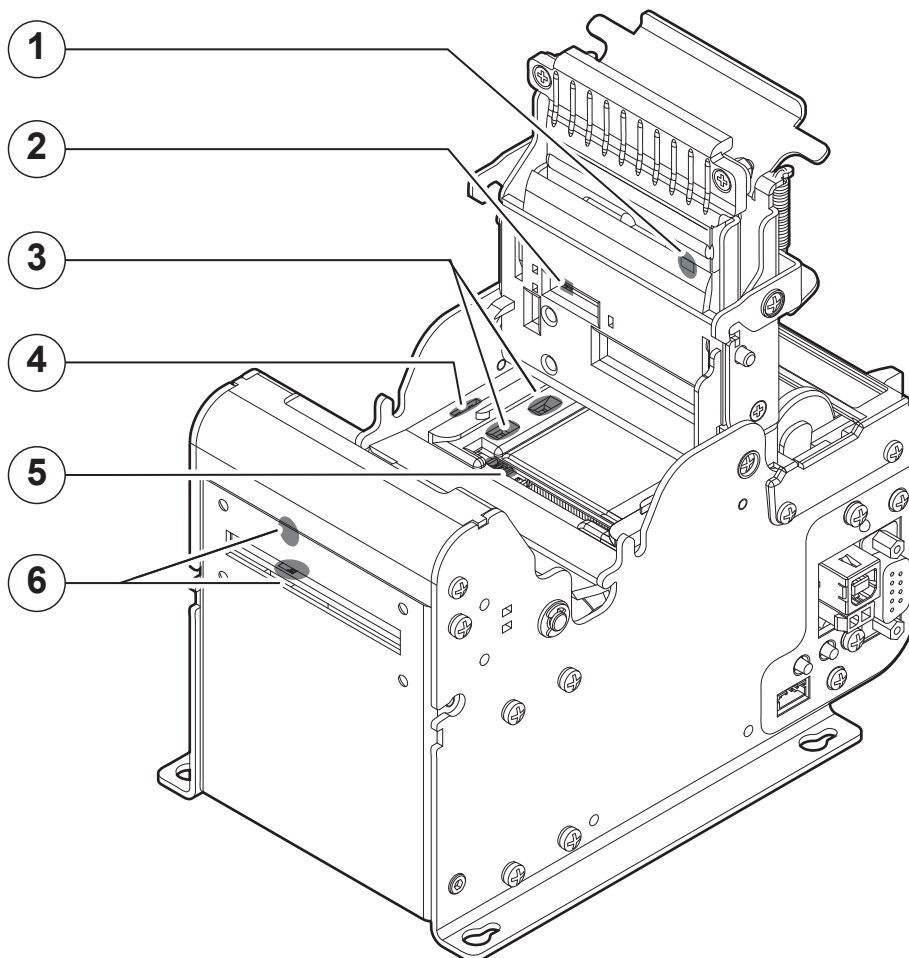



3.5 Product label

The main data used to identify the machine are shown on the label attached to the bottom of the device. In particular, it shows the electrical data for the connection to a power source. It also shows the product code, the serial number and the hardware revision (R).

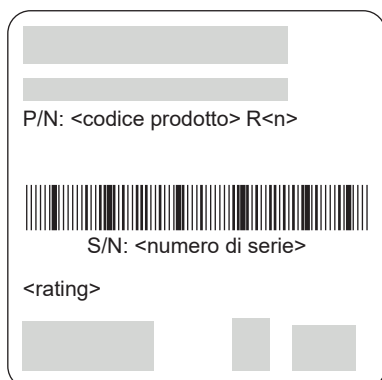

3.6 Key functions: power up

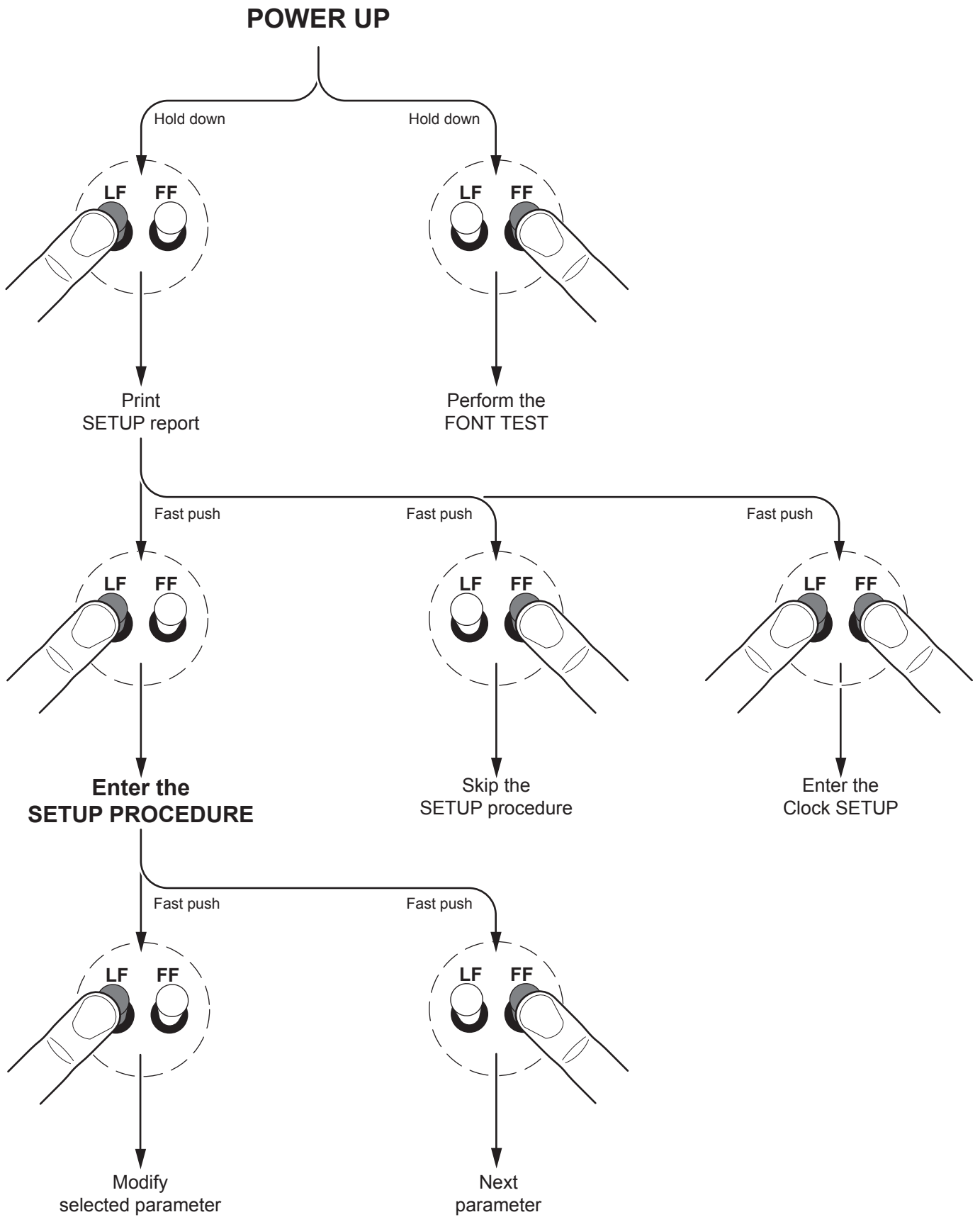

3.7 Key functions: standby

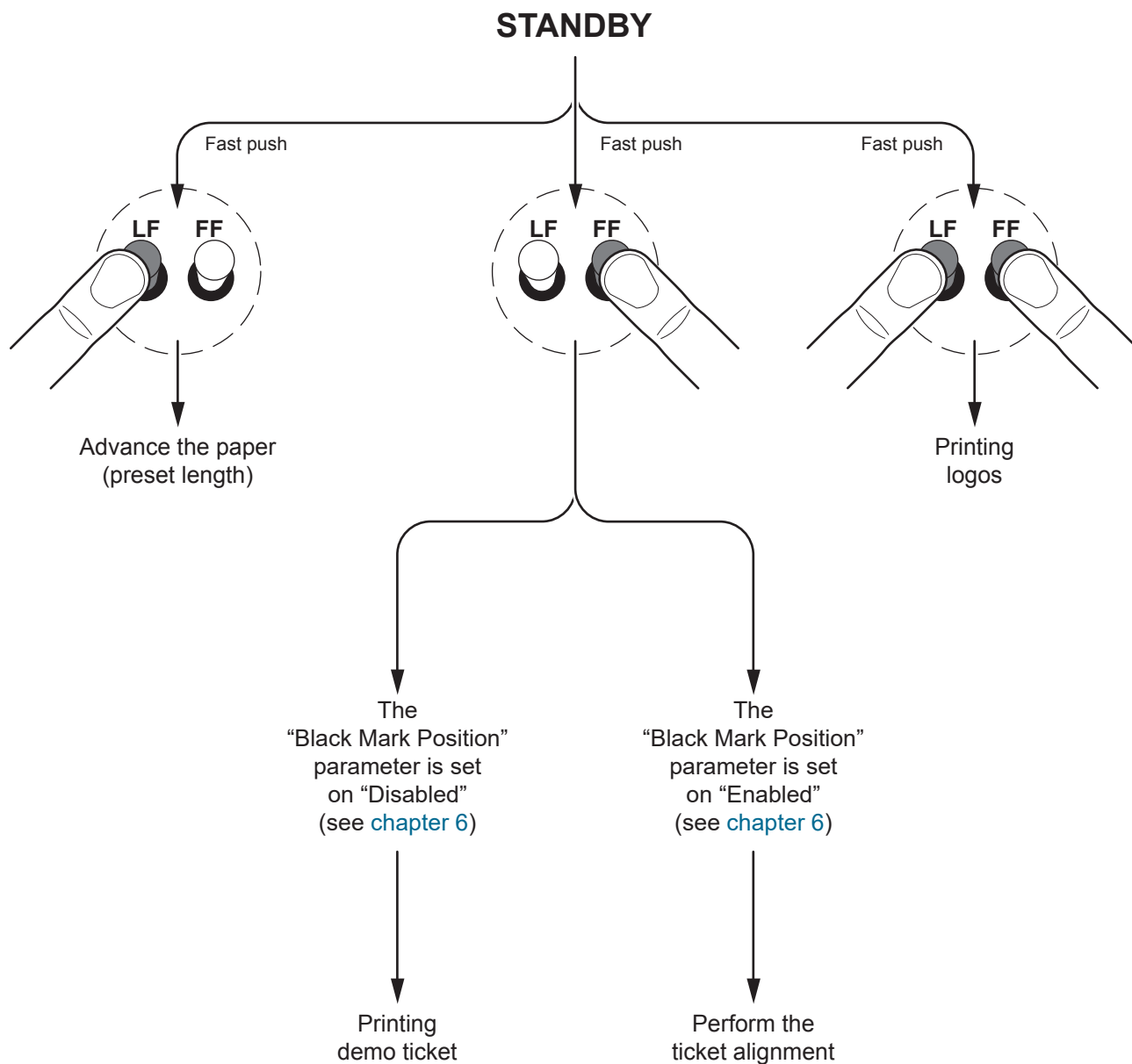



3.8 Status messages

The status LED indicates hardware status of device. Given in the table below are the various LED signals and the corresponding device status.

KPM150HIII.

STATUS LED		DESCRIPTION
-	OFF	PRINTER OFF
GREEN	ON	PRINTER ON: NO ERROR
GREEN COMMUNICATION STATUS	x 1	RECEIVE DATA
	x 2	RECEPTION ERRORS (PARITY, FRAME ERROR, OVERRUN ERROR)
	x 3	COMMAND NOT RECOGNIZED
	x 4	COMMAND RECEPTION TIME OUT
	X 5	LOW PAPER
YELLOW RECOVERABLE ERROR	x 2	PRINthead OVERHEATED
	x 3	PAPER END
	x 4	PAPER JAM
	x 5	POWER SUPPLY VOLTAGE INCORRECT
	x 6	COVER OPEN
RED UNRECOVERABLE ERROR	x 3	RAM ERROR
	x 4	EEPROM ERROR
	x 5	AUTOCUTTER ERROR

**B202HIII**

STATUS LED		DESCRIPTION
-	OFF	DEVICE OFF
BLUE	ON	DEVICE ON: NO ERROR
BLUE COMMUNICATION STATUS	x 1	RECEIVE DATA
	x 2	RECEPTION ERRORS (PARITY, FRAME ERROR, OVERRUN ERROR)
	x 3	COMMAND NOT RECOGNIZED
	x 4	COMMAND RECEPTION TIME OUT
	x 5	LOW PAPER
VIOLET RECOVERABLE ERROR	x 2	PRINthead OVERHEATED
	x 3	PAPER END
	x 4	PAPER JAM
	x 5	POWER SUPPLY VOLTAGE INCORRECT
	x 6	COVER OPEN
RED UNRECOVERABLE ERROR	x 3	RAM ERROR
	x 4	EEPROM ERROR
	x 5	AUTOCUTTER ERROR

4 INSTALLATION

4.1 Fixing

KPM150HIII

The printer is provided with four fixing holes placed on lateral side (see following figure). To fasten the printer on a panel, use four M3 screws.

All the dimensions shown in figures are in millimeters.

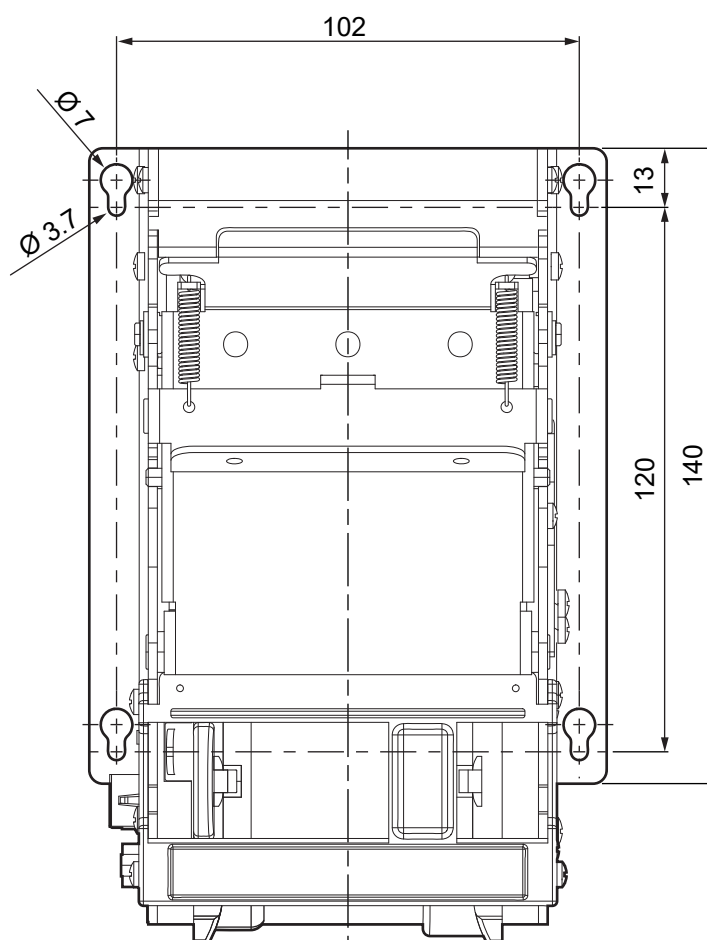



4.2 Additional low paper sensor

KPM150HIII.

The device includes an additional low paper sensor with wiring cable (see following figure). To fix the sensor use an M3 screw not supplied.

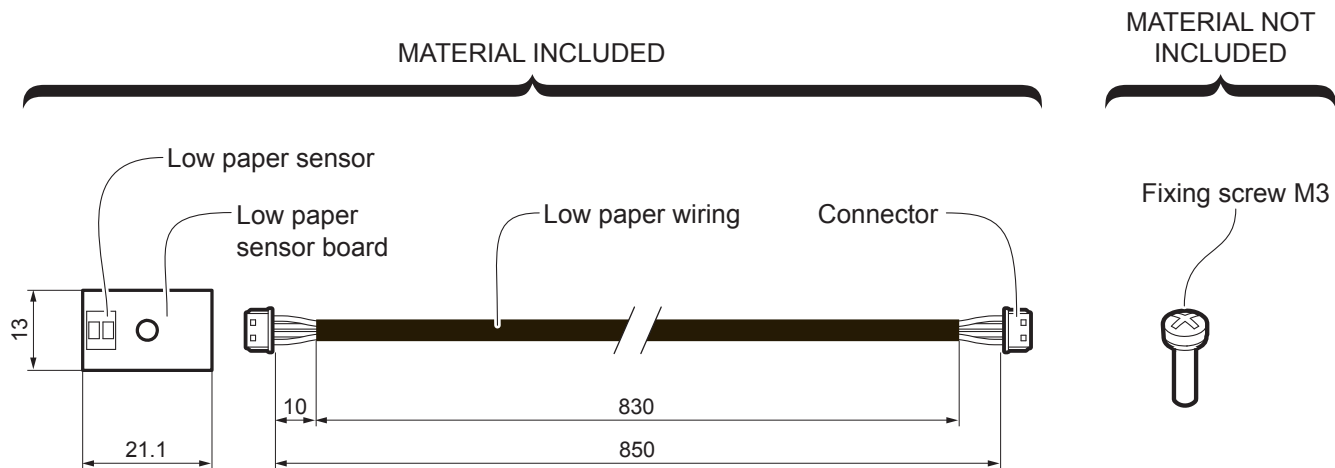

For the assembly procedure, proceed as follows:

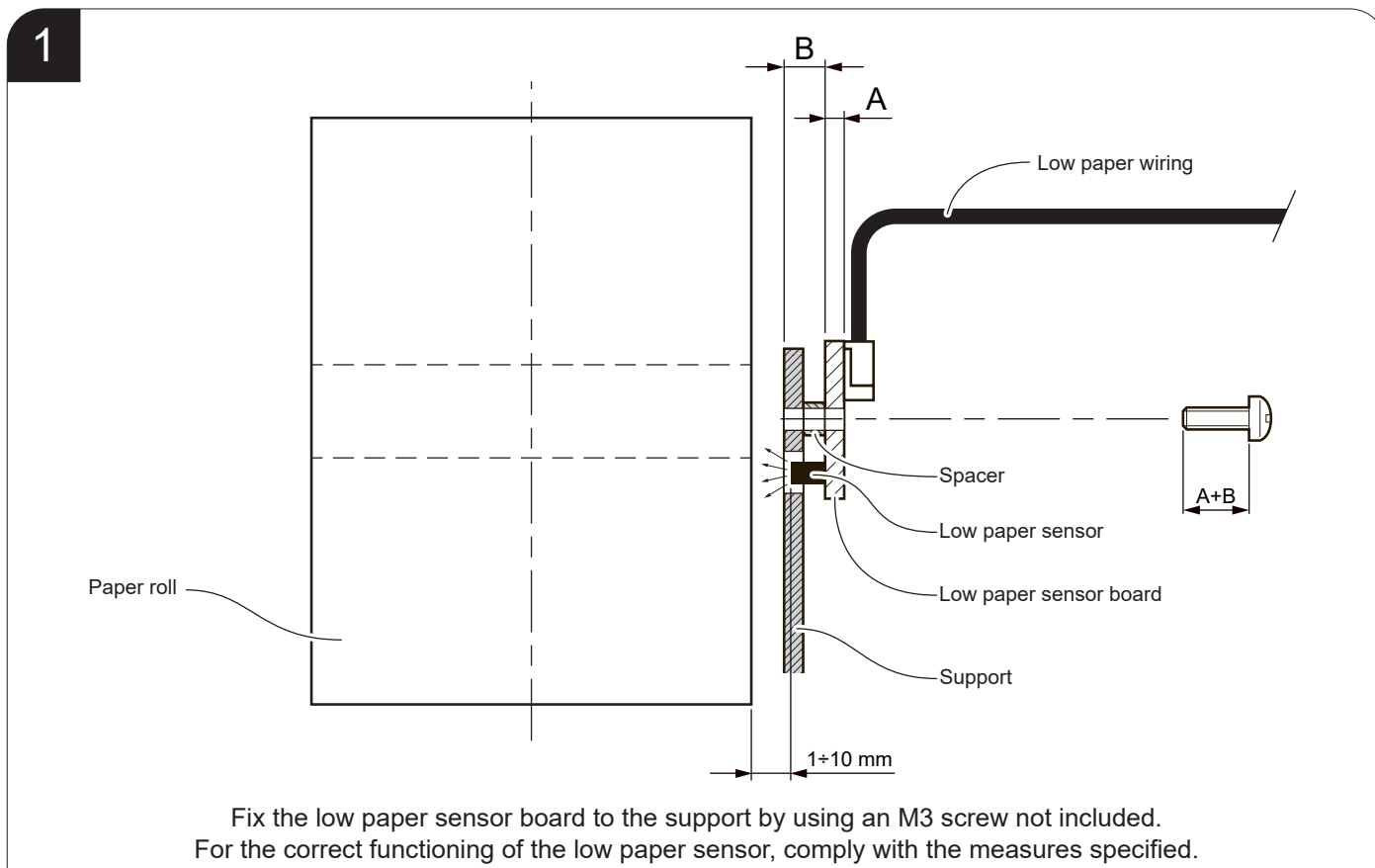

2

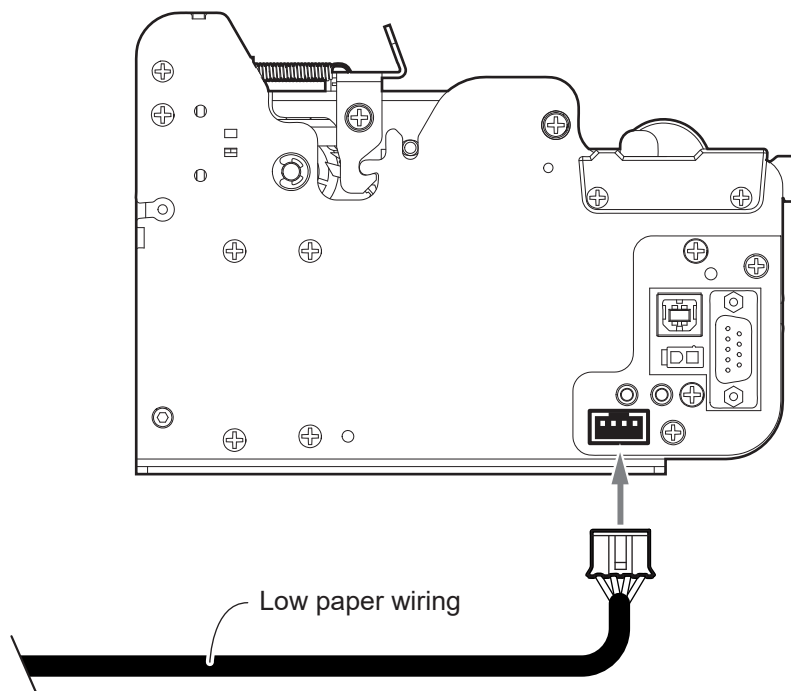

Connect the wiring coming from the low paper sensor board at the connector shown in figure.



B202HIII

The device not includes a low paper sensor kit. It is available as an accessory (see [chapter 11](#)) the low paper sensor board code 81300000000383 and the wiring cable code 26300000000519 (see following figure). To fix the sensor use an M3 screw not supplied.

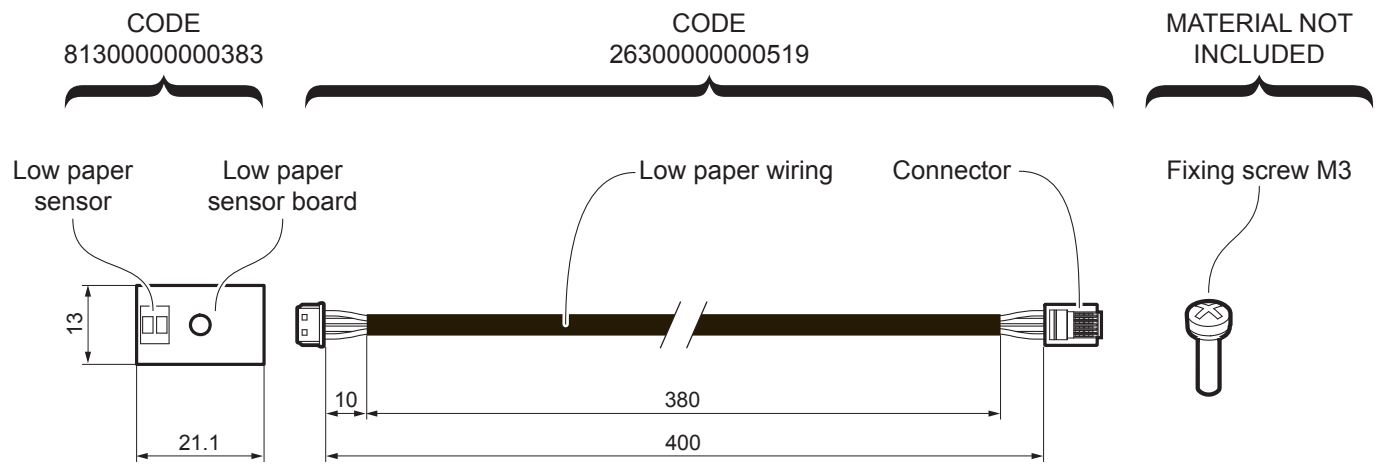

For the assembly procedure, proceed as follows:

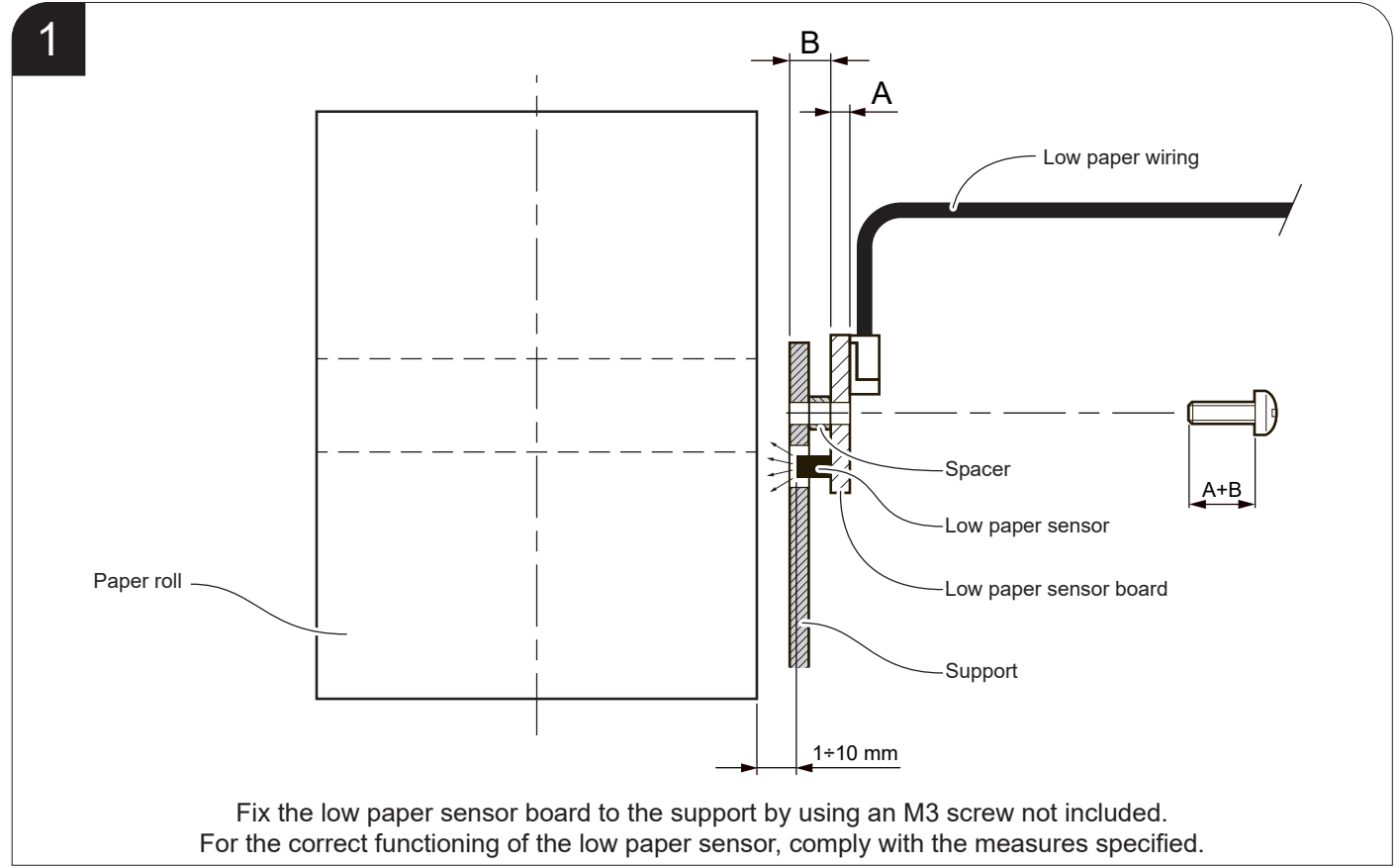

2

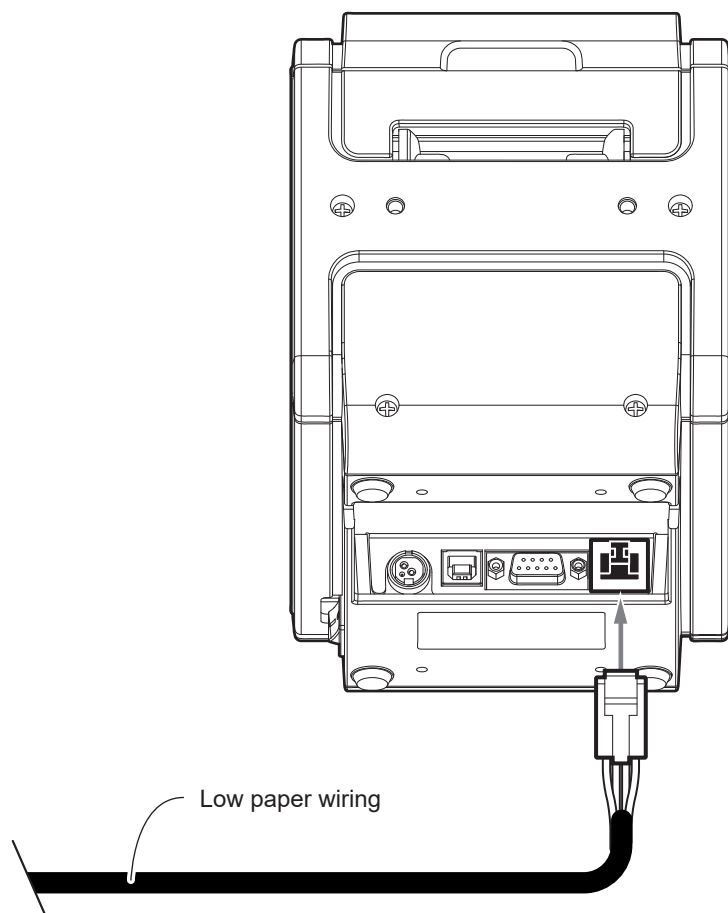

Low paper wiring

Connect the wiring coming from the low paper sensor board at the connector shown in figure

4.3 Connections

The following figures show the possible connections for the devices.

When the RS232 and USB communication cables are connected to the printer at the same time, communication takes place via the USB port.

ATTENTION: In some using conditions, we recommend the installation of a ferrite core on the power supply cable.

KPM150HIII

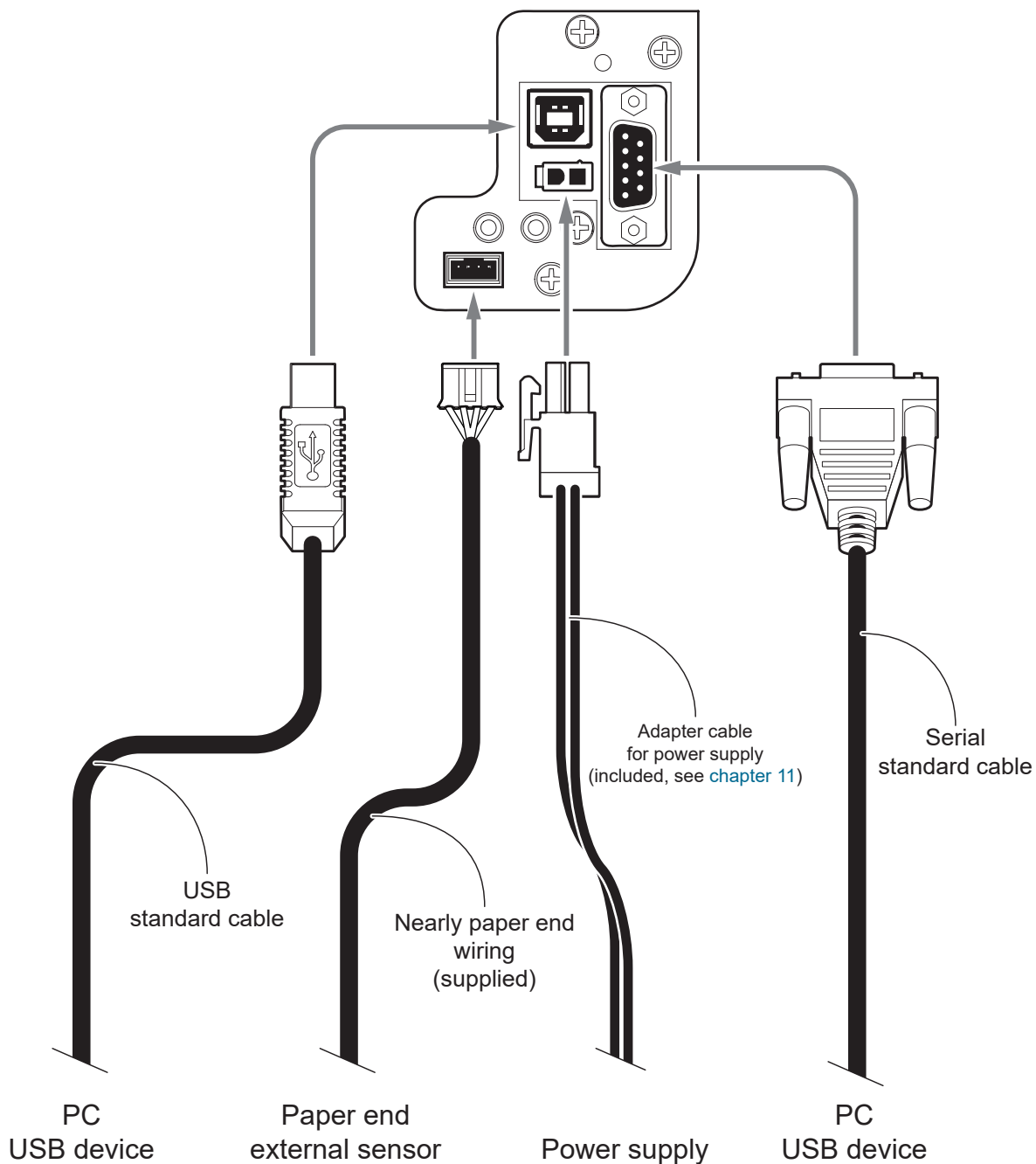

B202HIII

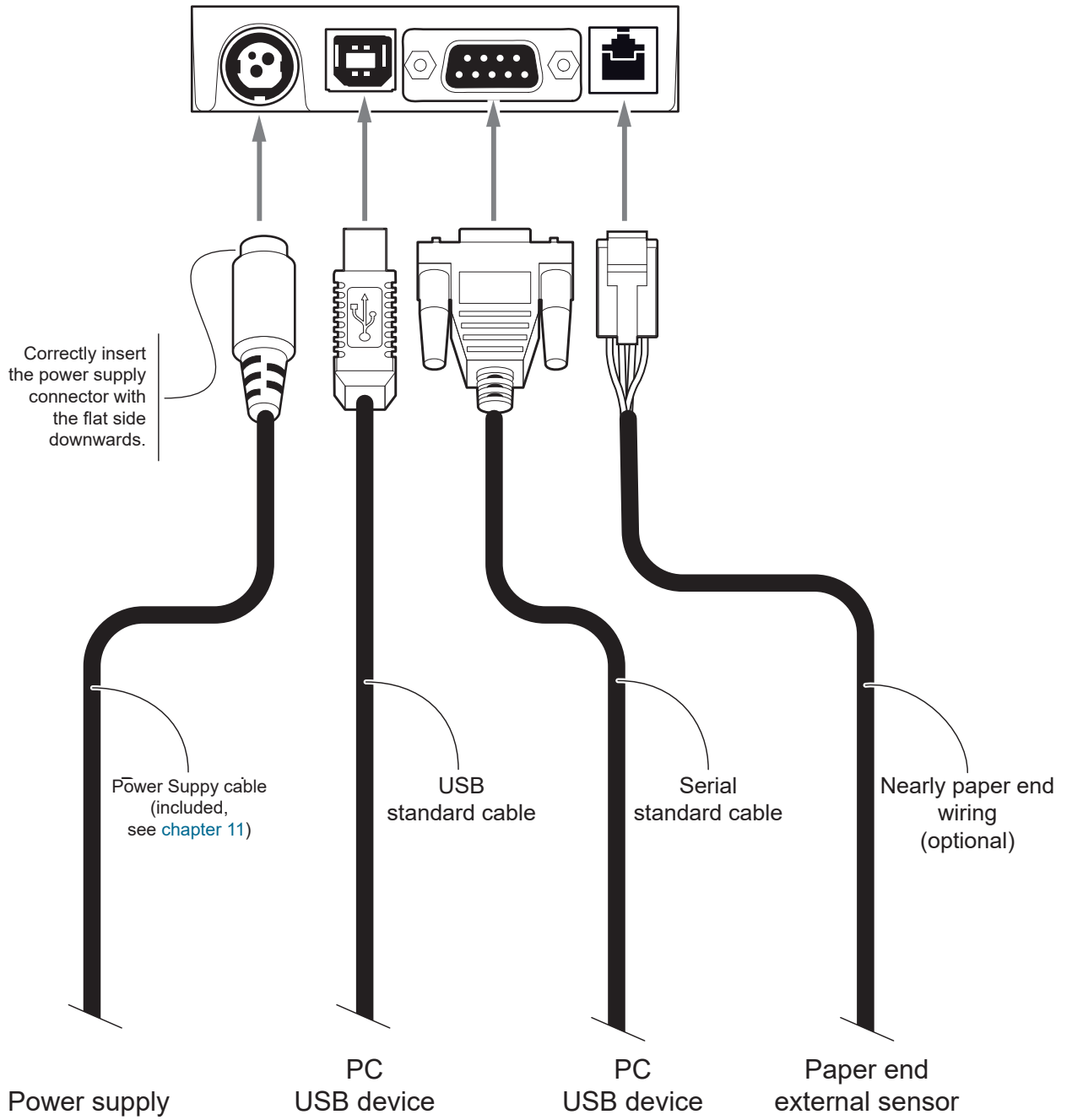

4.4 Pinout

KPM150HIII



POWER SUPPLY

Male Molex connector series 5566 vertical (no. 39-28-1023)

J13	1	+24 Vdc
	2	GND

Power supply cable

The following figure shows the connector pinout of the power supply cable for the device:

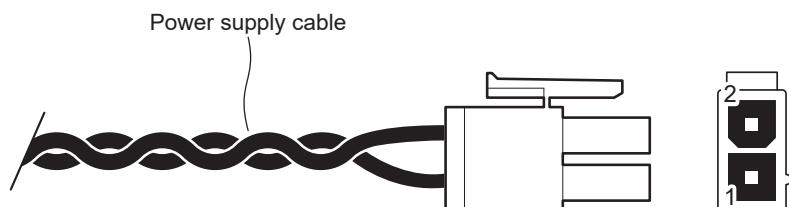

Female Molex connector series 5557 (n° 39-01-3022)

PIN	Cable color	Signal
1	Red	+24 V
2	Black	GND

ATTENTION:
Respect power supply polarity.

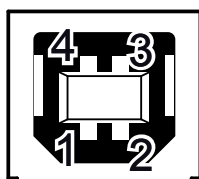

USB INTERFACE

Female USB type B connector

J1	1	USBHS-VBUS	(in)
	2	USBHS_D-	(in/out)
	3	USBHS_D+	(in/out)
	4	GND	
	SH1	SHIELD	
	SH2	SHIELD	



RS232 SERIAL INTERFACE

Female DB9 connector

J3	1	DTR	When +VRS232, device is power on
	2	TX	During transmission, takes the values -VRS232 and + VRS232 depending on data
	3	RX	During reception, takes the values -VRS232 and +VRS232 depending on data
	4	DSR	
	5	GND	
	6	DTR	When +VRS232, device is power on
	7	CTS	
	8	RTS	When +VRS232, device is ready to receive data
	9	n.c.	

Given the presence of the RS232 standard, logic value "0" corresponds to the voltage value +VRS232 (voltage value between +3Vdc and +15Vdc) and logic value "1" corresponds to the voltage value -VRS232 (voltage value between -3Vdc and -15Vdc).

DEVICE > PC connection

The following picture shows an example of connection between the device and a personal computer using a 9 pin RS232 serial connector:

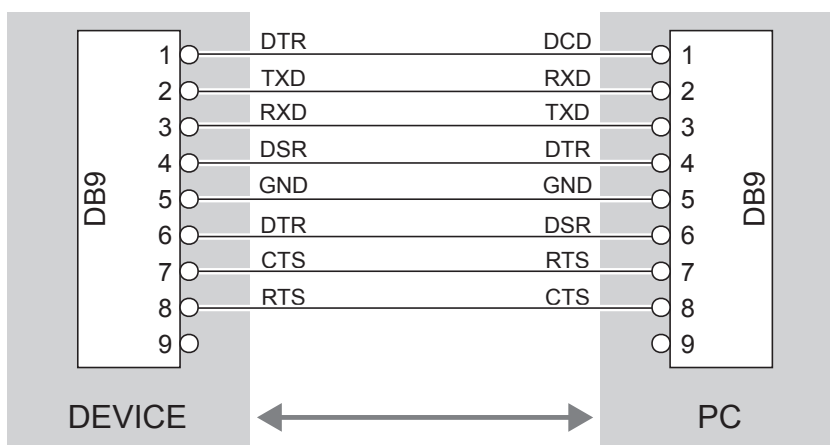

When use a serial cable, we recommend the installation of a ferrite core on the power supply cable.



B202HIII



POWER SUPPLY
Tripolar female connector

J2	1	GND
	2	+24 Vdc
	3	GND
	4	Frame GND

Power supply cable

The following figure shows the connector pinout of the power supply cable for the device:

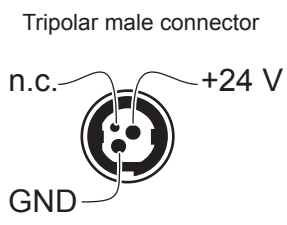
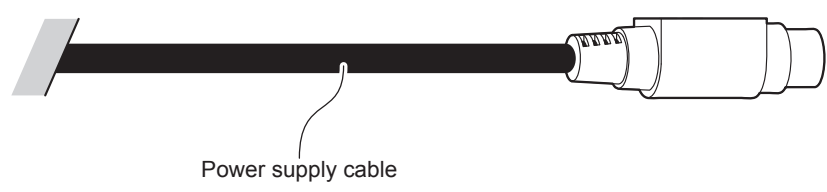

ATTENTION:
Respect power supply polarity.

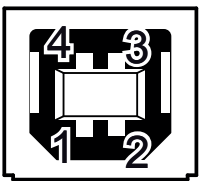

USB INTERFACE
Female USB type B connector

J4	1	VUSB	(in)
	2	D-	(in/out)
	3	D+	(in/out)
	4	GND	
	SH1	SHIELD	
	SH2	SHIELD	

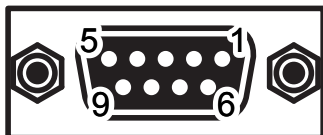

RS232 SERIAL INTERFACE

Female DB9 connector

J3	1	DTR	When +VRS232, device is power on
	2	TX	During transmission, takes the values -VRS232 and + VRS232 depending on data
	3	RX	During reception, takes the values -VRS232 and +VRS232 depending on data
	4	DSR	
	5	GND	
	6	DTR	When +VRS232, device is power on
	7	CTS	
	8	RTS	When +VRS232, device is ready to receive data
	9	n.c.	

Given the presence of the RS232 standard, logic value "0" corresponds to the voltage value +VRS232 (voltage value between +3Vdc and +15Vdc) and logic value "1" corresponds to the voltage value -VRS232 (voltage value between -3Vdc and -15Vdc).

DEVICE > PC connection

The following picture shows an example of connection between the device and a personal computer using a 9 pin RS232 serial connector:

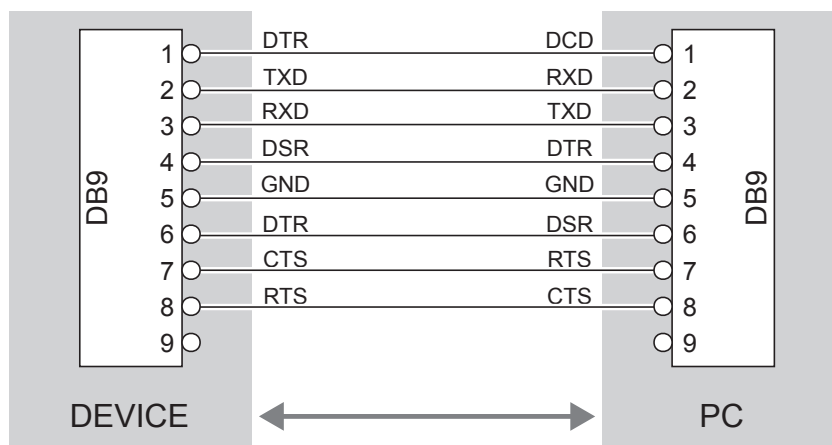

When use a serial cable, we recommend the installation of a ferrite core on the power supply cable.



4.5 Driver and SDK

The drivers for the following operating system are available in the website www.custom4u.it

OPERATING SYSTEM	DESCRIPTION	INSTALLATION PROCEDURE
Windows	Driver for Windows XP	From the START menu, press Run and type-in the path where the SW was saved on your PC, then click OK. Follow the instructions that appear on the screen to install the driver.
	Driver for Windows VISTA (32/64bit)	
	Driver for Windows 7 (32/64bit)	
	Driver for Windows 8 (32/64bit)	
	Driver for Windows 8.1 (32/64bit)	
	Driver for Windows 10 (32/64bit)	
	Self-installing driver for VIRTUAL COM (32/64 bit) (see paragraph 6.6)	
Linux	Driver for Linux (32/64bit)	Follow the instruction get back on the "Readme.txt" file. You can find it in the software package downloaded in advance.
Android	Library for CustomAndroidAPI	Extract the zipped folder to the destination path desired. Follow the instructions present in the software package that you downloaded on how to install and use the library..
iOS	Library for CustomiOSApi	Extract the zipped folder to the destination path desired. Follow the instructions present in the software package that you downloaded on how to install and use the library.

5 OPERATION

5.1 Opening device cover

KPM150HIII.

1

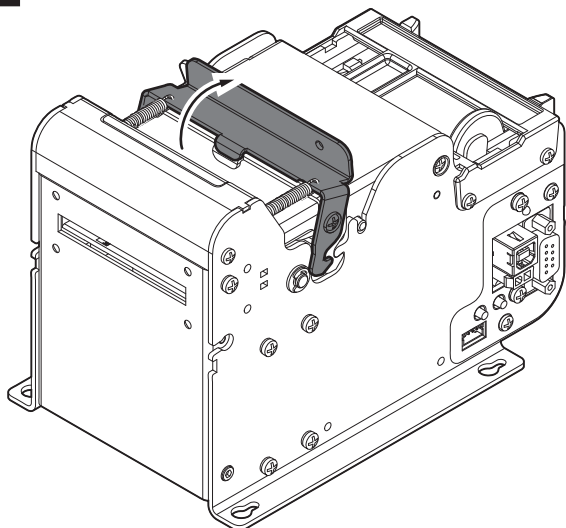

Push the opening lever in the direction shown in the figure.

2

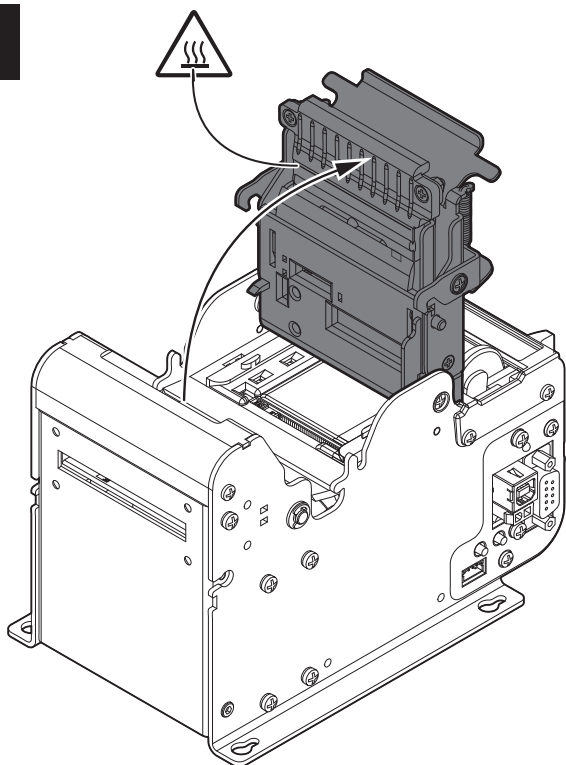

Open the upper cover of the device.

B202HIII

1

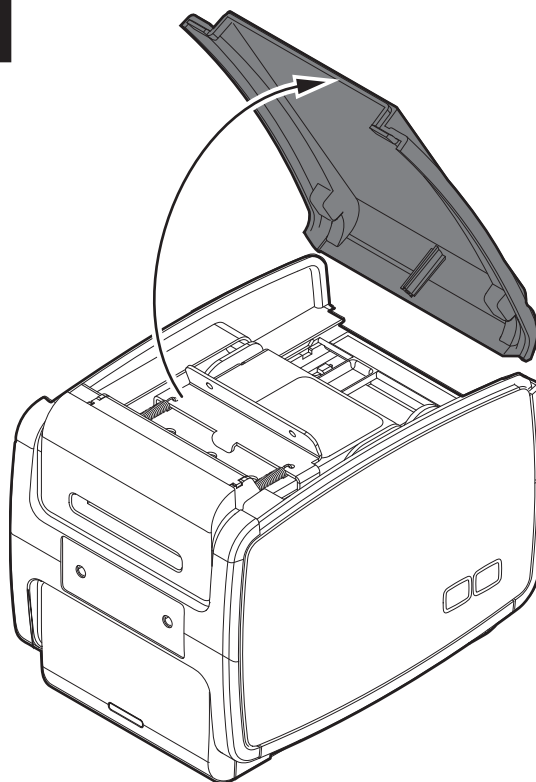

Open the upper plastic cover.

2

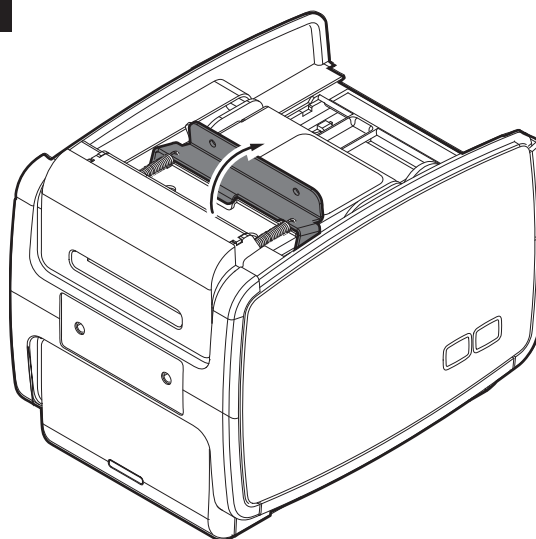

Open the paper compartment cover.

5.2 Adjusting paper width

For ease of reference, it is represented only the internal printer without the external plastic chassis. Paper width may be adjusted from 20 mm to 54 mm using the lever of paper mouth guide located at the paper infeed opening as shown in the following figure.

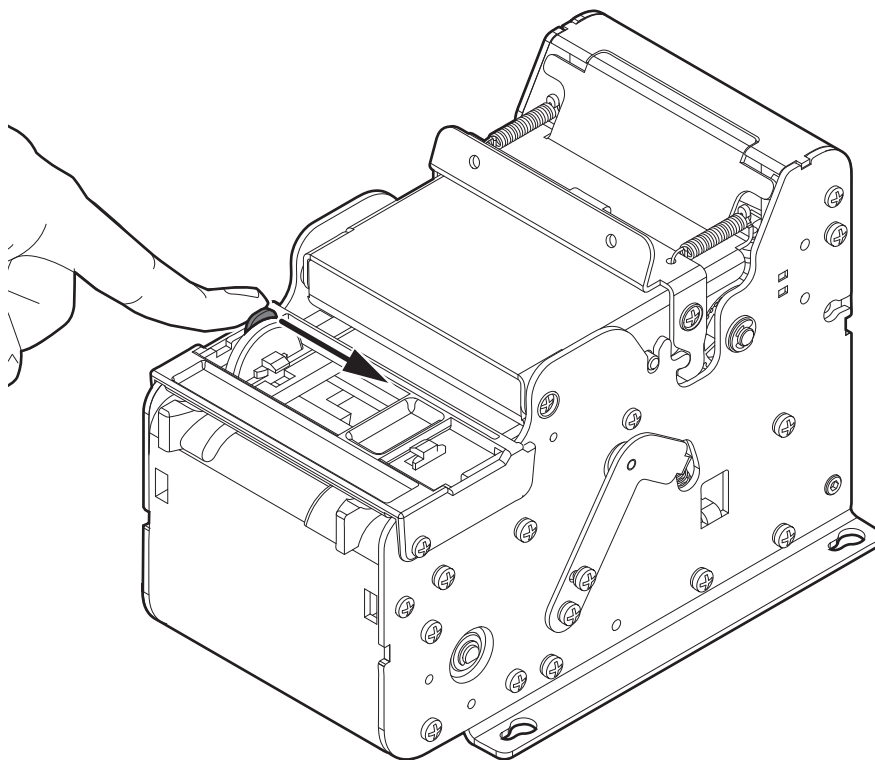

To adjust the paper width, proceed as follows:

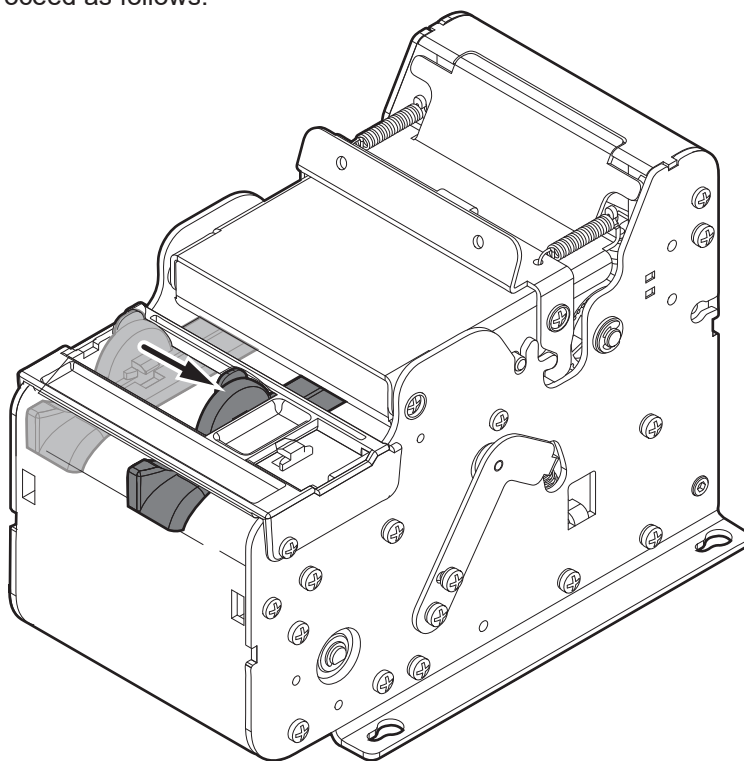

5.3 Adjusting the alignment sensors

For ease of reference, it is represented only the internal printer without the external plastic chassis. The device is equipped with a mobile sensor for the detection of the alignment black mark placed both on the non-thermal side of paper (located lower than the plane of the paper inside the device) as shown in the following figure. The device user will need to manually move this mobile sensor according to the position of the black mark on the paper (see [chapter 7](#)). To use this sensor, you must set the “Black Mark Position” setup parameter on the “Bottom” value (see [chapter 6](#)).

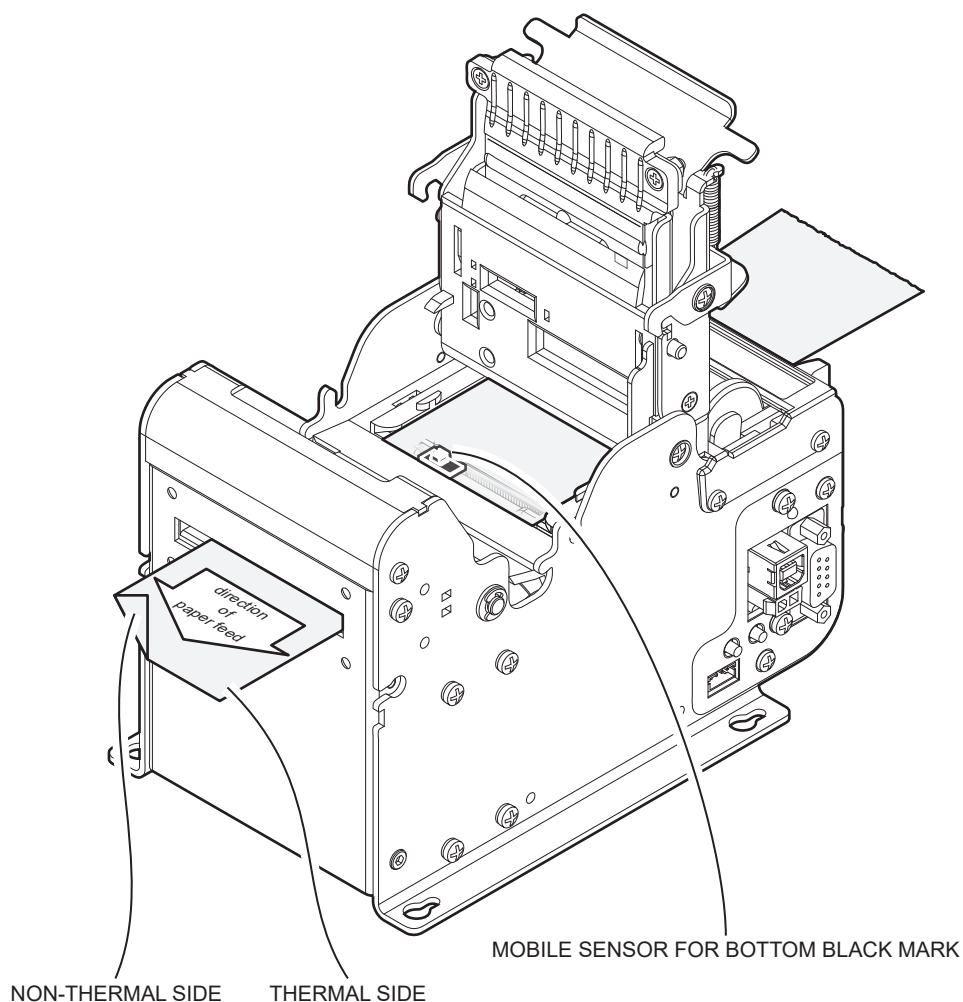



In addition, the device is equipped with another sensor for black mark alignment placed on the thermal side of paper (located upper than the plane of the paper inside the device). This sensor is positioned on the upper flat under the print head and is fixed.

To use this sensor for black mark detection, you must set the “Black Mark Position” setup parameter on the “Top” value (see [chapter 6](#)).

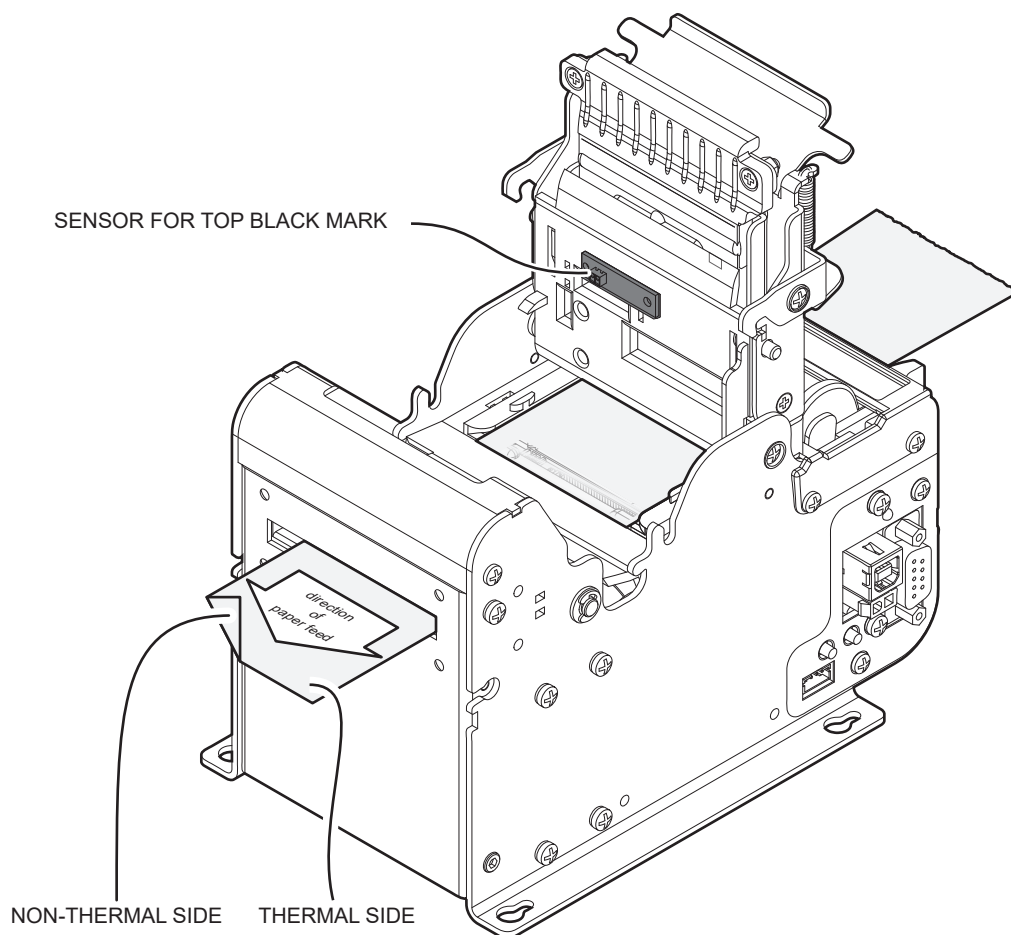



To adjust the mobile sensor position according to the Black Mark Position on paper, first adjust the paper width (see [paragraph 5.2](#)), then open the device cover (see [paragraph 5.1](#)) and move the sensor to the desired using a small screwdriver or a pointed object.

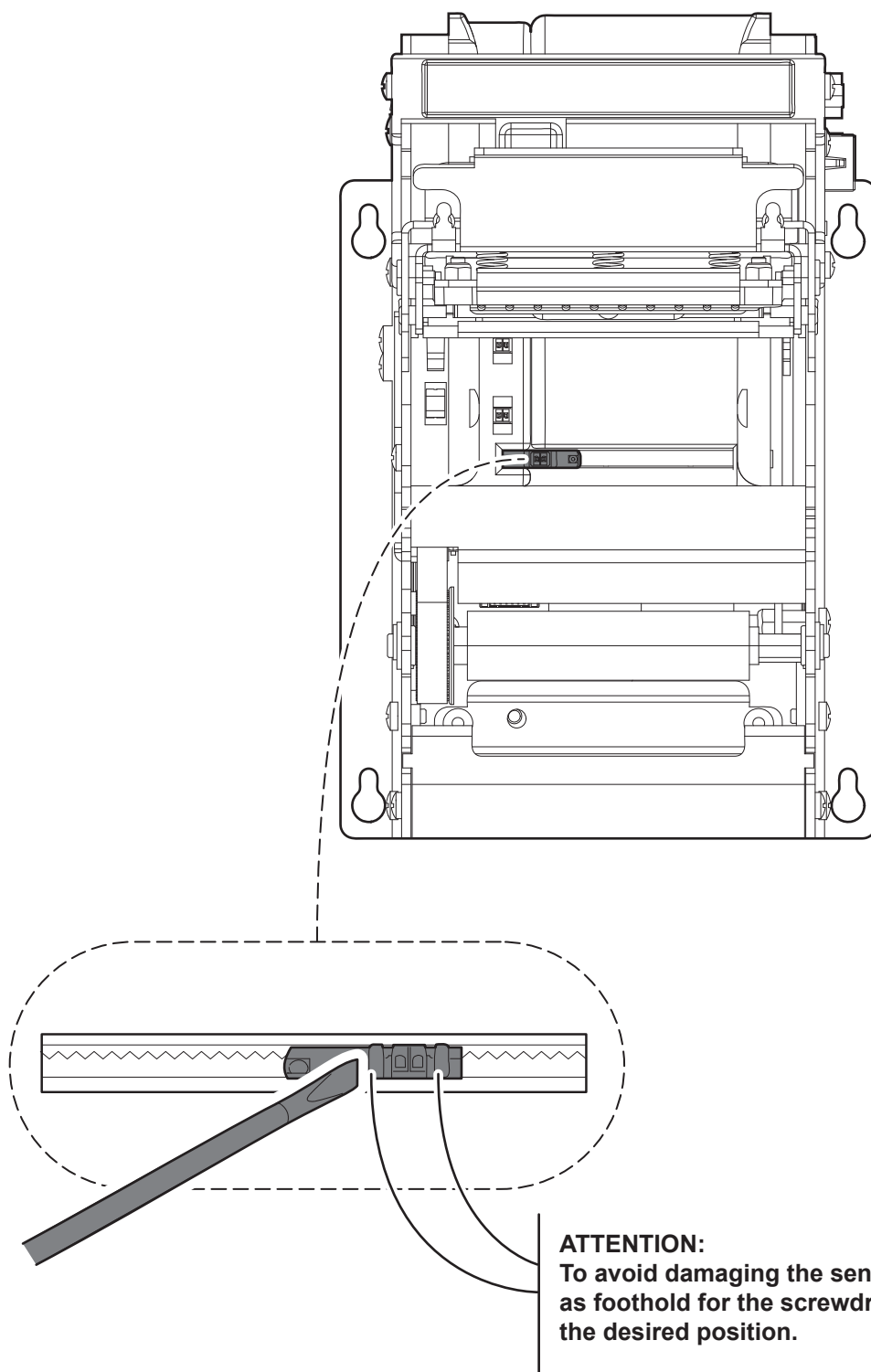

5.4 Switch the device on

KPM150HIII

1

Power supply
(optional)

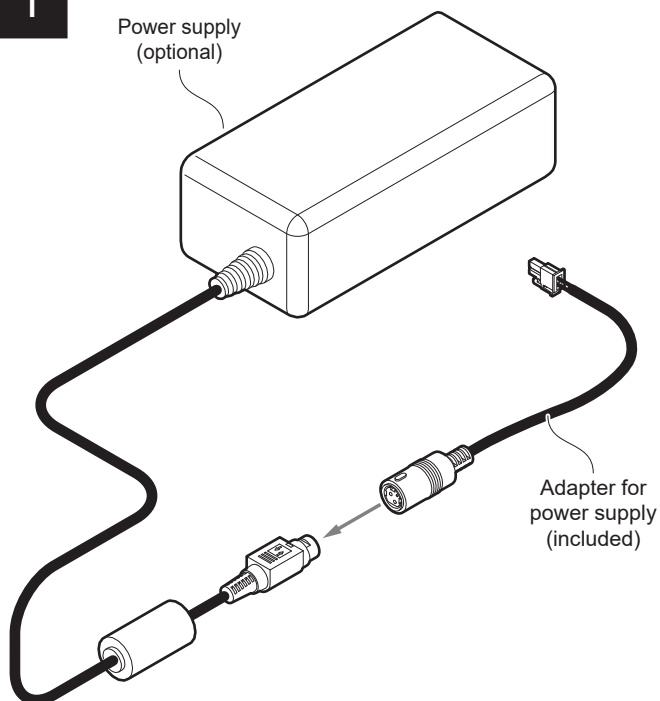

Adapter for
power supply
(included)

Connect the power adapter (included)
to an external power supply unit.

2

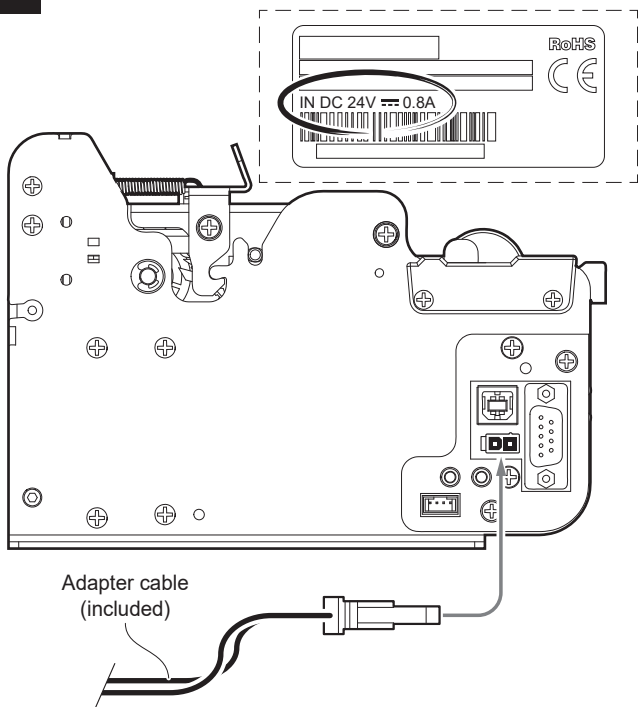

Adapter cable
(included)

Connect the power adapter cable to the device.
Use the type of electrical power supply
indicated on the label.

3

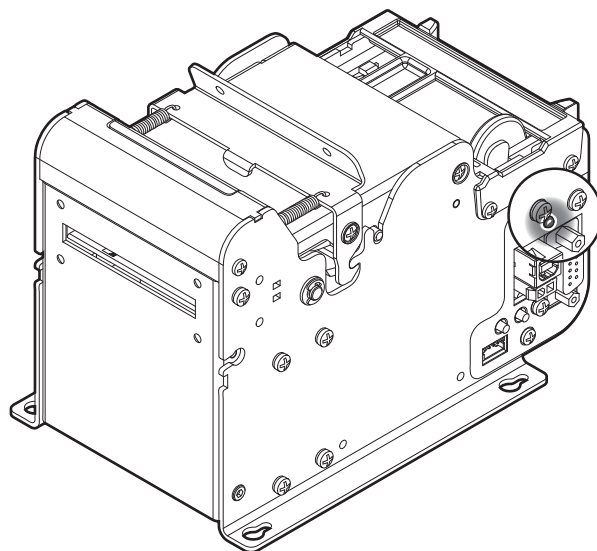

The green LED turns on
and the device is ready.

B202HIII

1

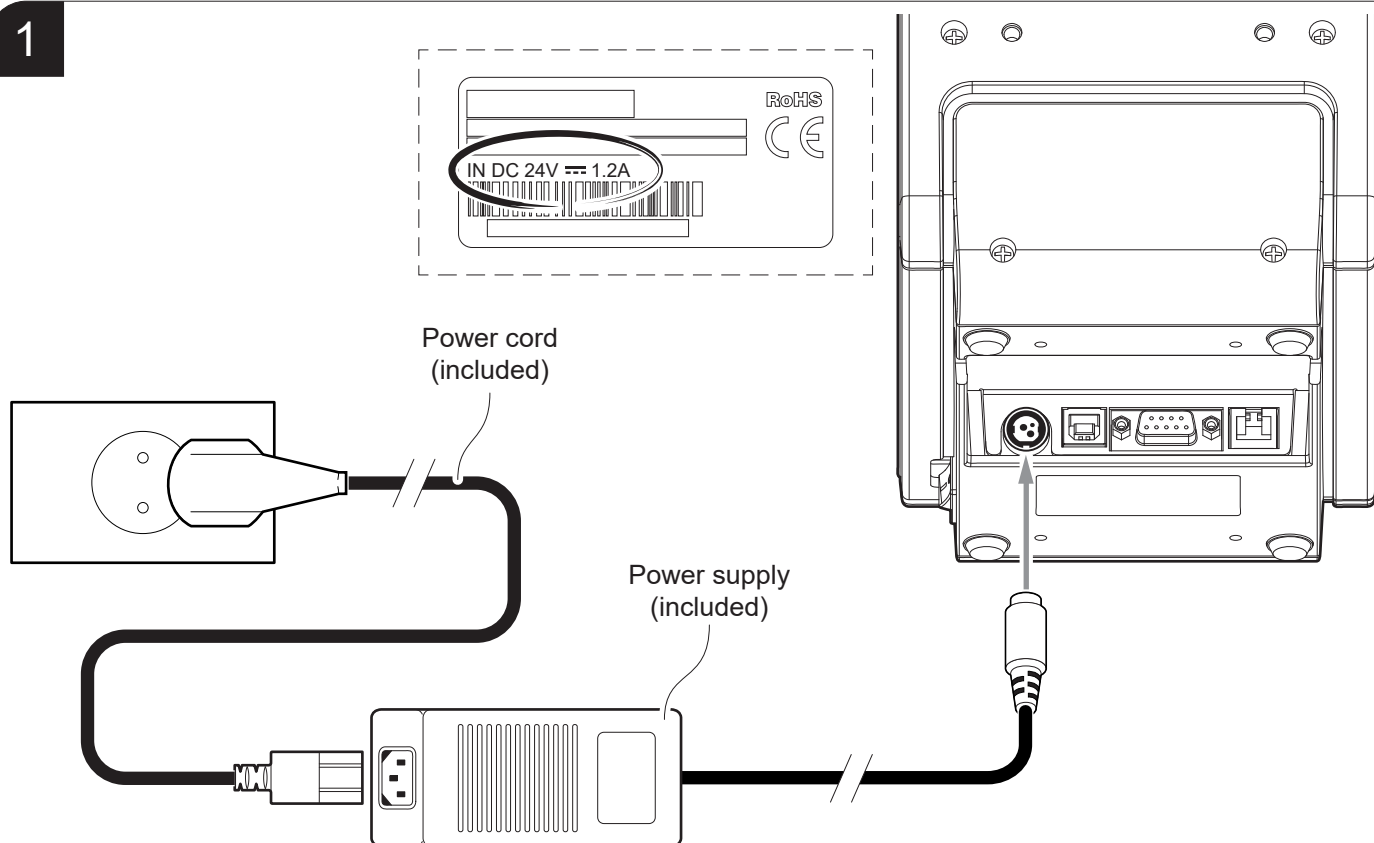

Connect the power adapter (included) to the device and the mains outlet.
Use the type of electrical power supply indicated on the label.

2

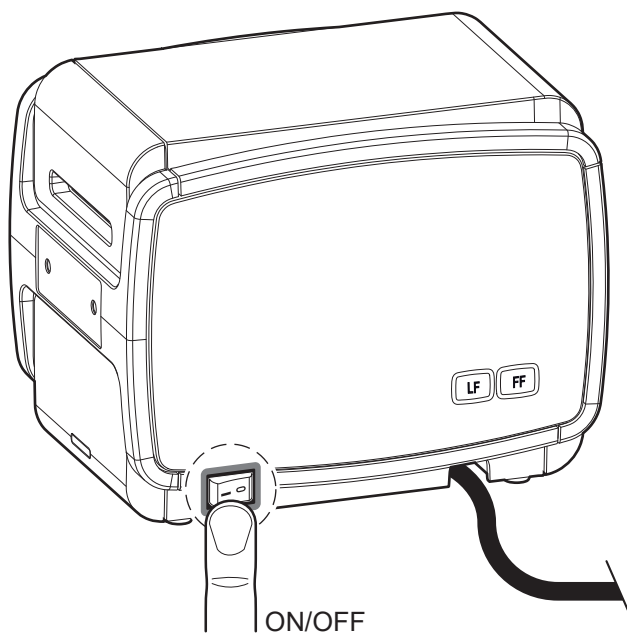

Switch the device on pressing ON/OFF key.
The blue LED turns on and the device is ready.



5.5 Loading the paper roll

At every change of paper, check inside the device. To change the paper proceed as follows.

KPM150HIII

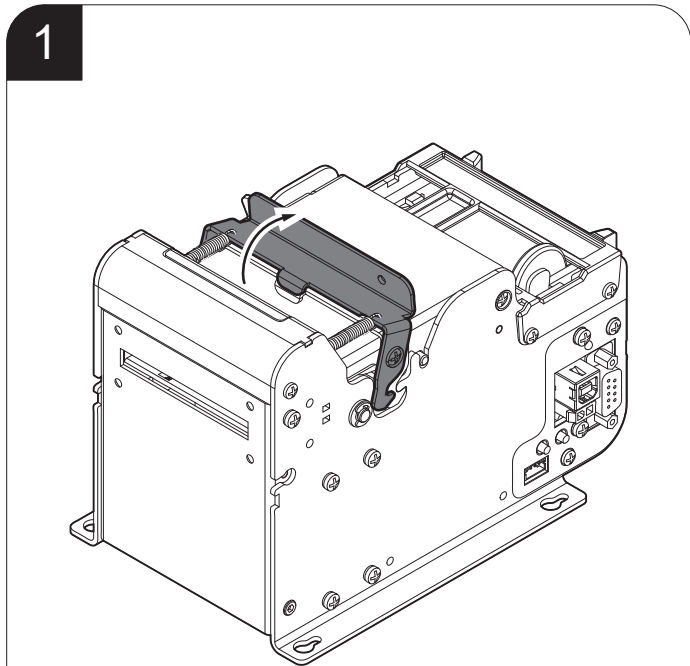

Push the opening lever in the direction shown in the figure.

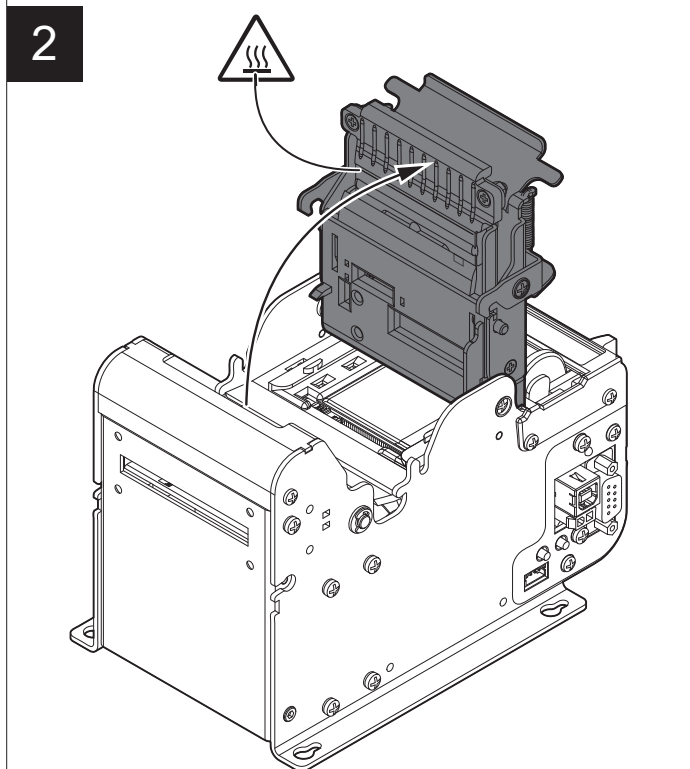

Open the upper cover of the device.

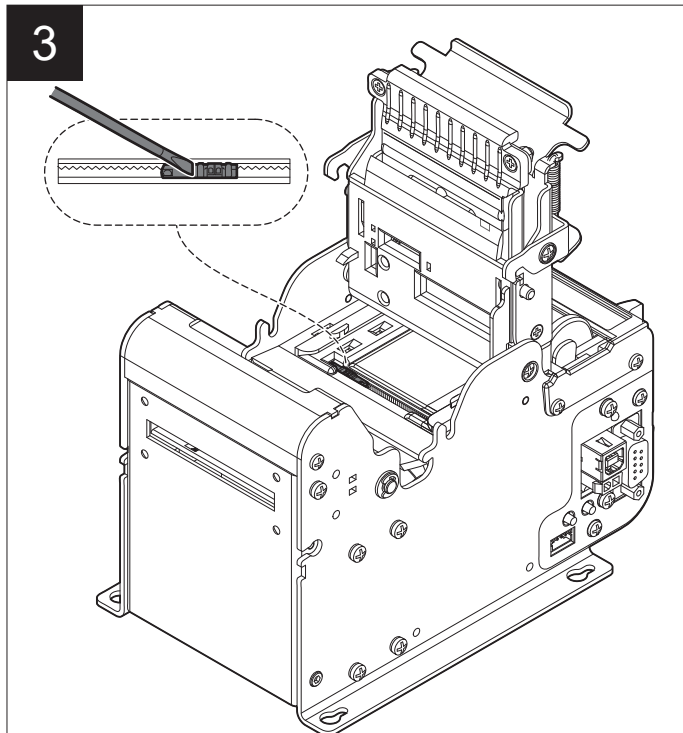

Adjust black mark sensor position (see [paragraph 5.3](#)).

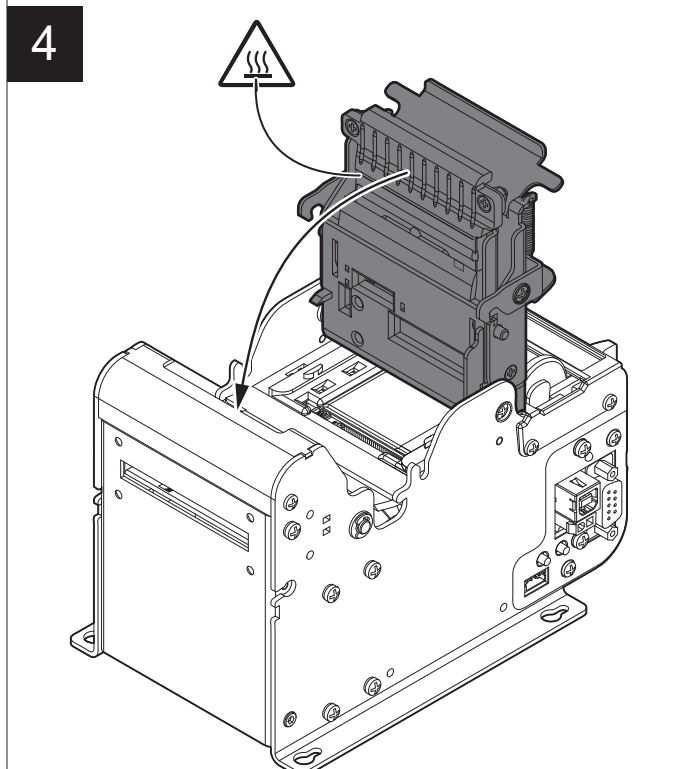

Close the upper cover of the device.

5

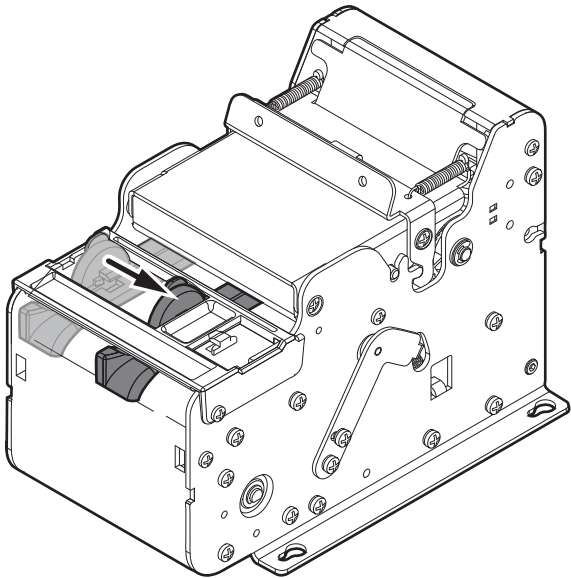

Adjust the paper width
(see [paragraph 5.2](#)).

6

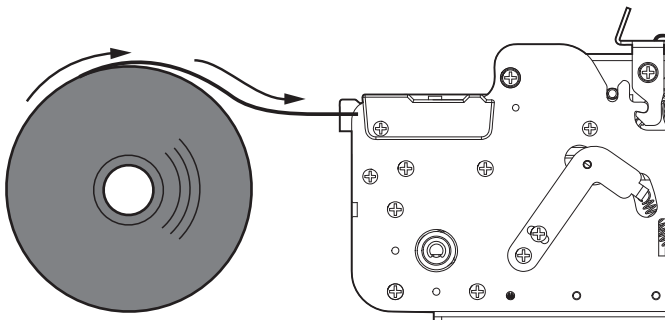

Insert the paper into the input mouth so that it unrolls correctly. Be sure that the paper is correctly positioned into paper guides.

7

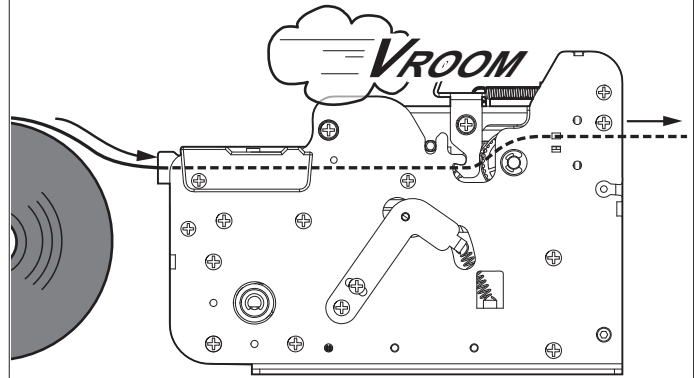

Wait until the paper is
automatically loaded.



B202HIII

1

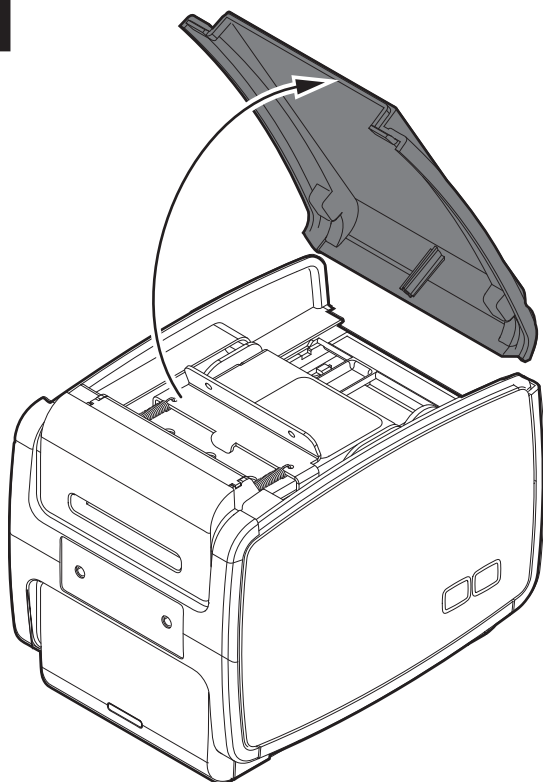

Open the upper plastic cover.

2

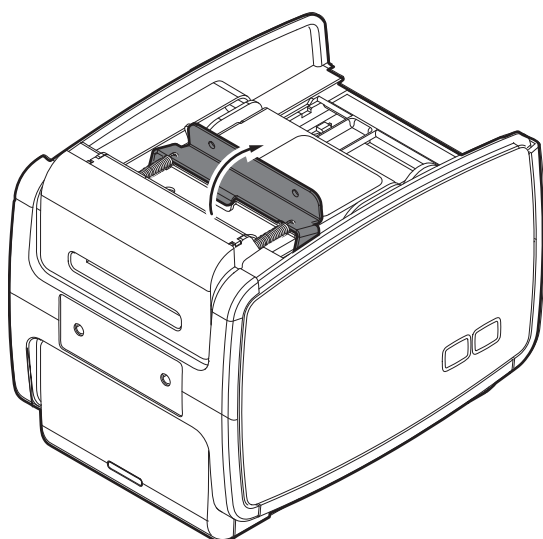

Adjust the paper width properly.

3

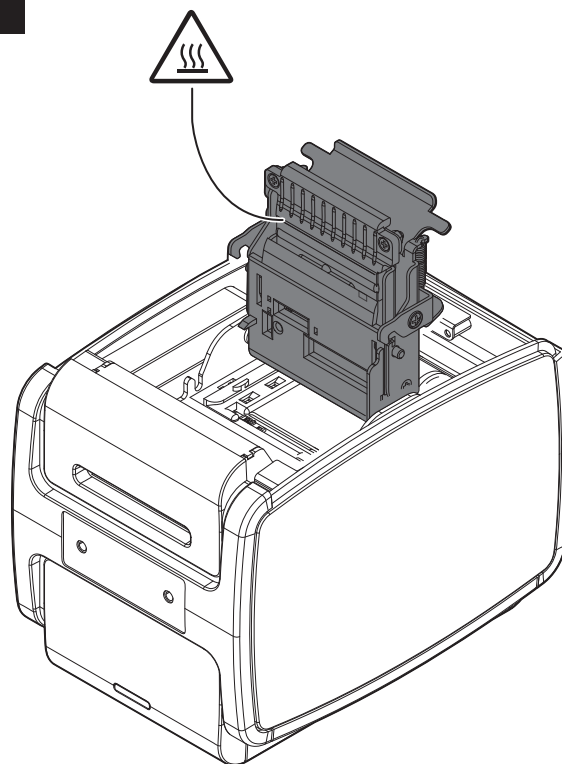

Open the paper compartment cover.

4

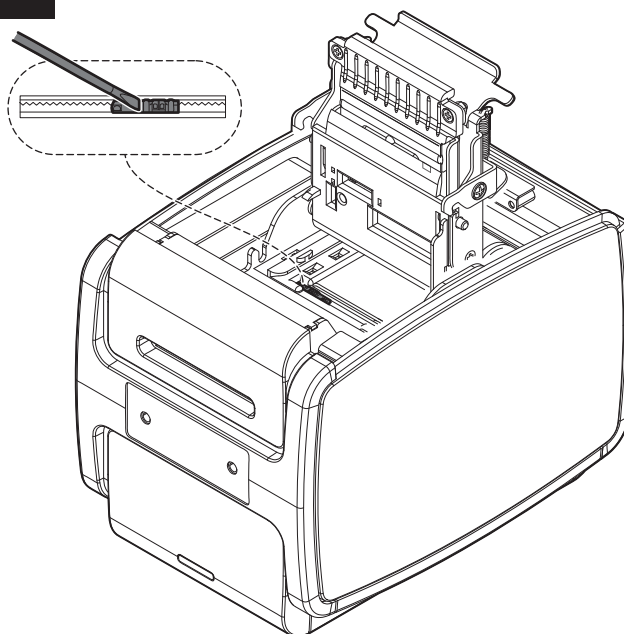

Adjust black mark sensor position
(see [paragraph 5.3](#)).

5

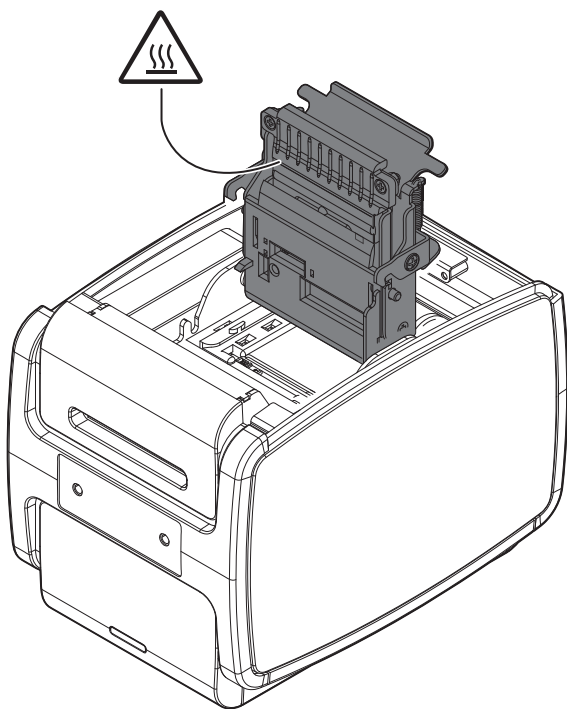

Close the paper compartment cover.

6

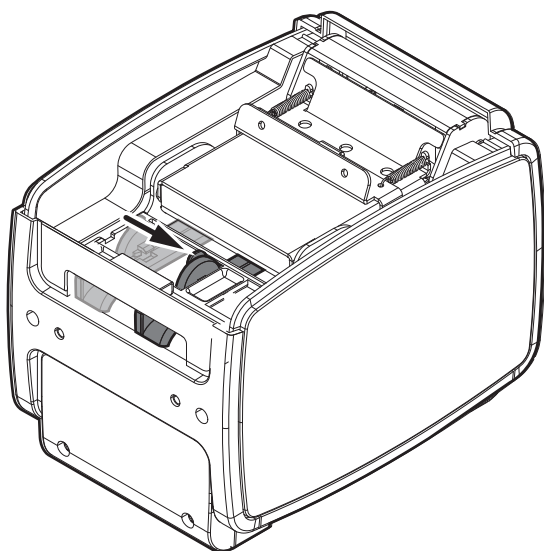

Adjust the paper width
(see [paragraph 5.2](#)).

7

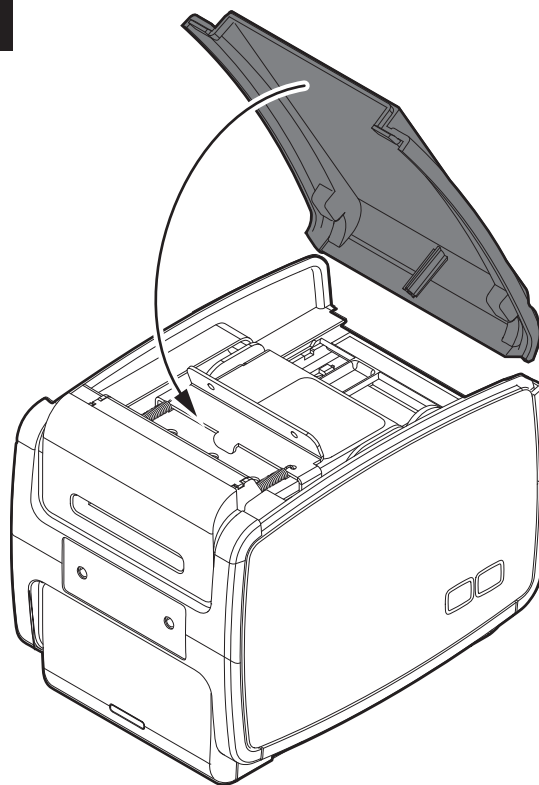

Close the
upper plastic cover.

8

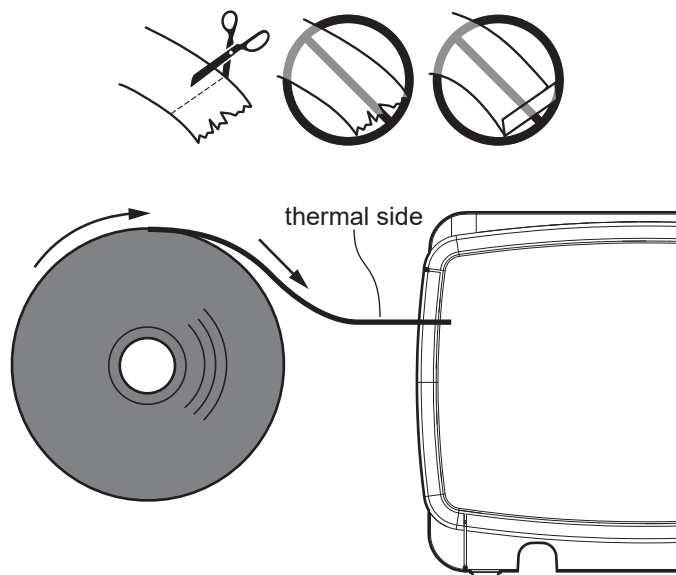

Insert the paper into the input mouth so that it unrolls
correctly. Be sure that the paper is
correctly positioned into paper guides.

9

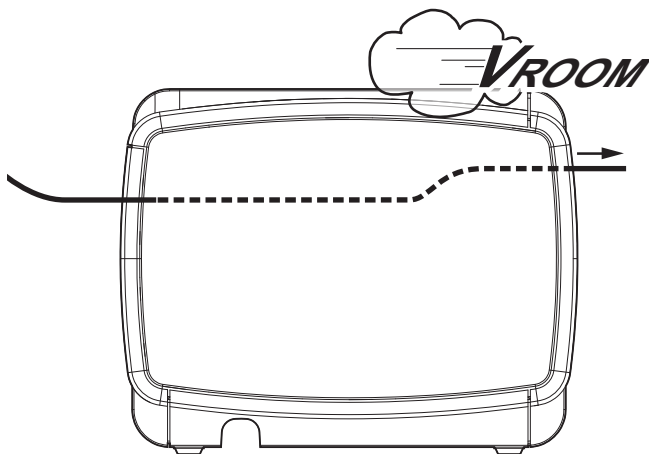

Wait until the paper is automatically loaded.



The following figure gives the limit positions of the paper roll related to the printer for a correct paper loading without a paper roll holder support.

The direction of the paper will always form a maximum angle of 90° or -90° with the insertion plane of paper inside the printer.

For ease of reference, in some figures is represented only the internal printer without the external plastic chassis.

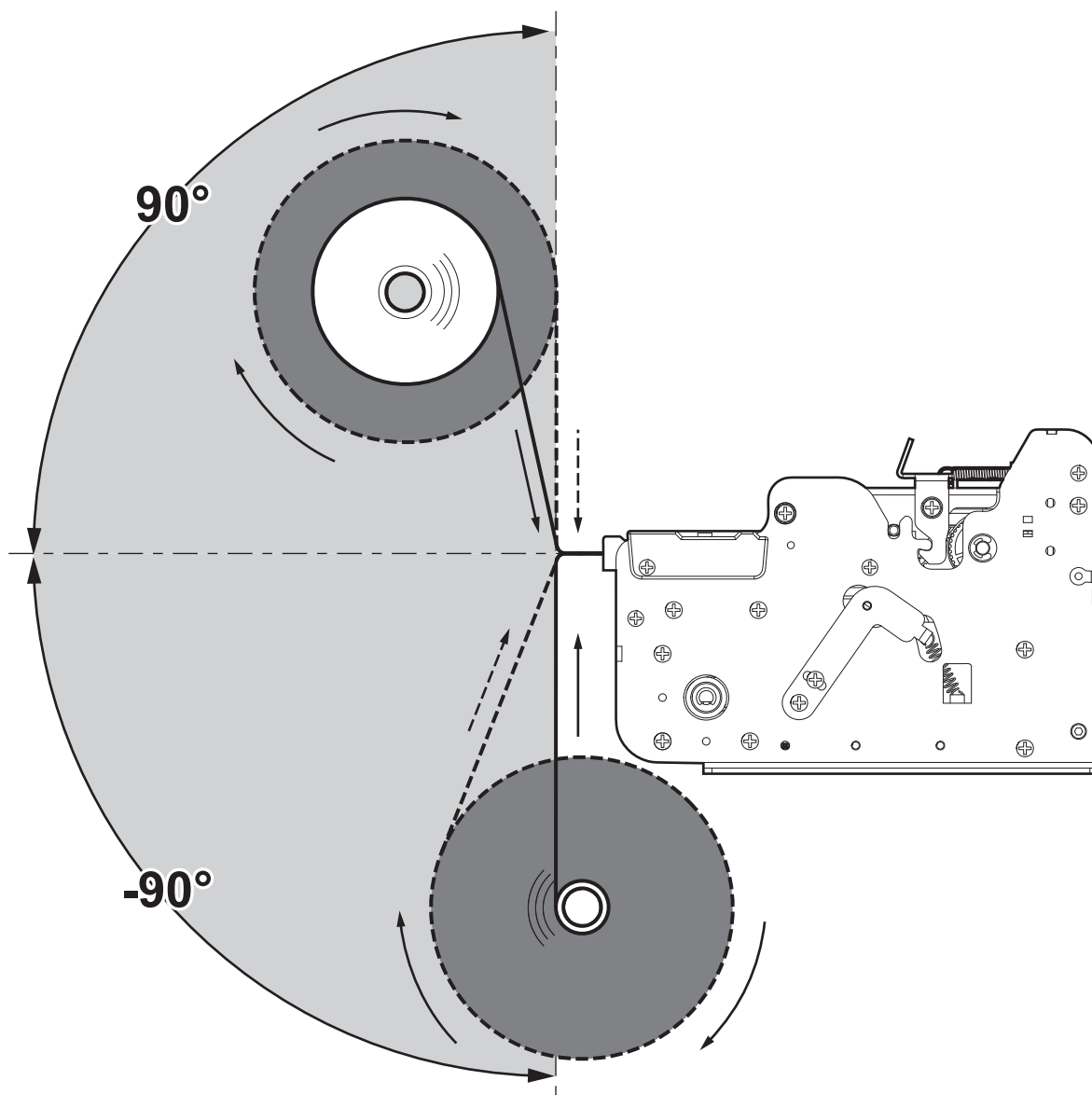



6 CONFIGURATION

6.1 Configuration by keys

To enter the configuration mode and print a setup report with the operating parameters of the device, proceed as follows.

KPM150HIII

1

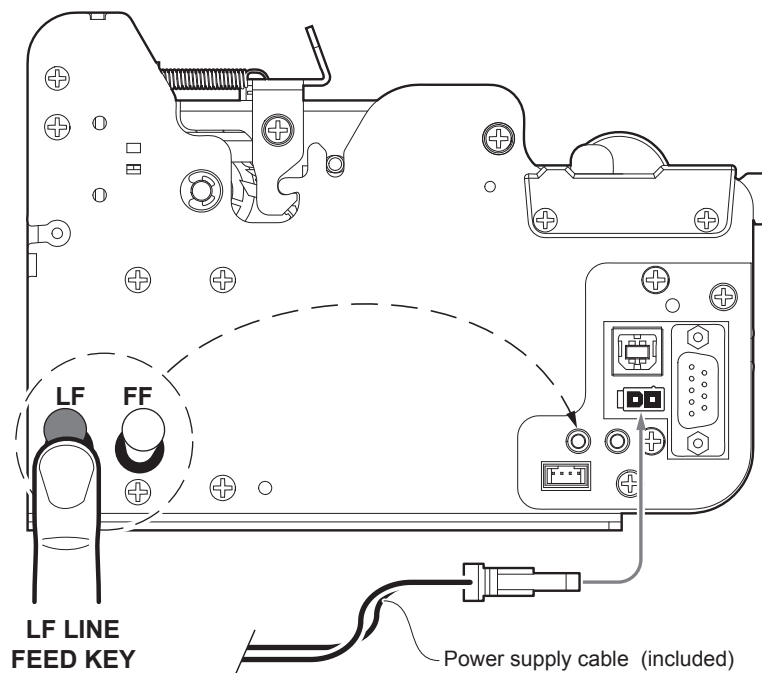

While pressing the LF LINE FEED key, switch on the device by connecting the power supply cable (see [paragraph 5.4](#)).

2

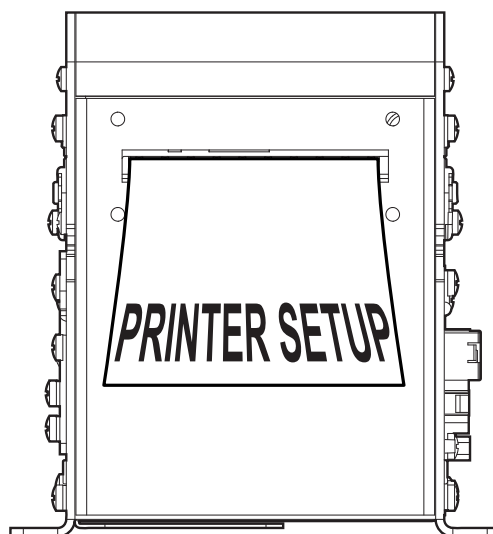

The device prints the report with the settings parameters.
Follow the instruction printed on the paper to proceed with configuration procedure.

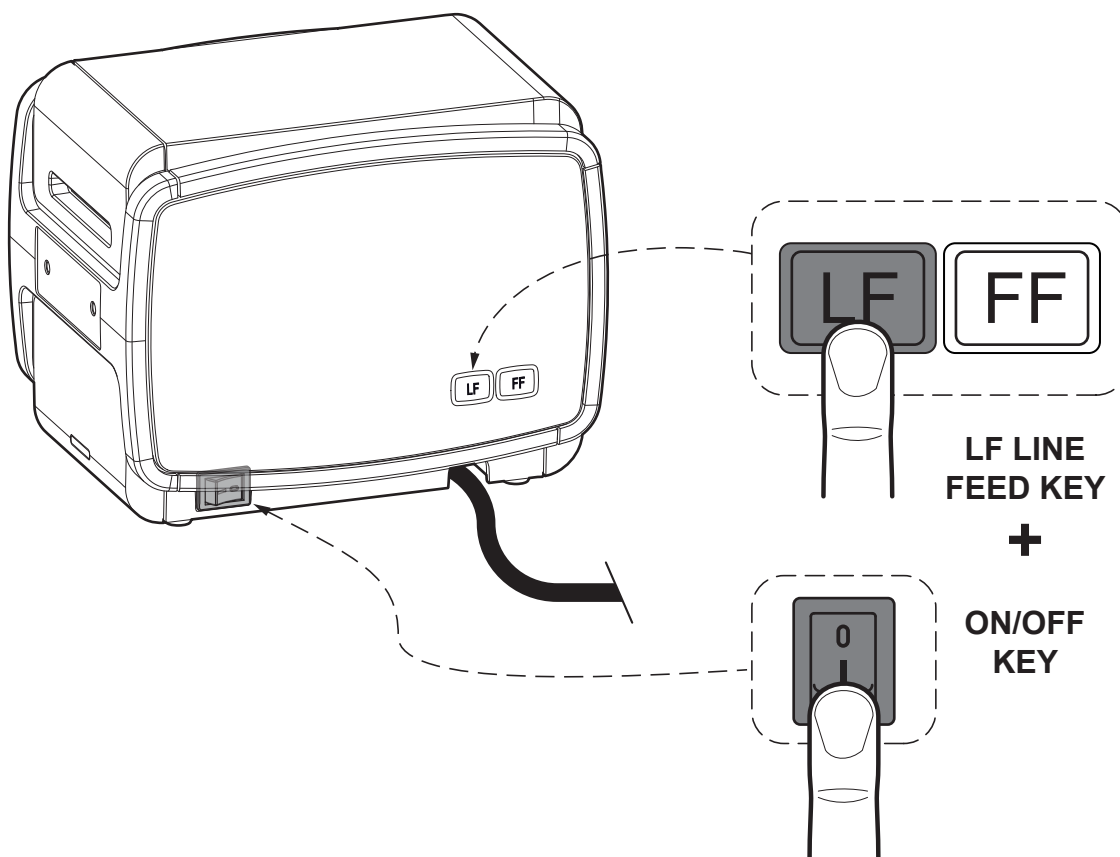
B202HIII**1**

While pressing the LF LINE FEED key, switch on the device by pressing the ON/OFF key (see [paragraph 5.4](#)).

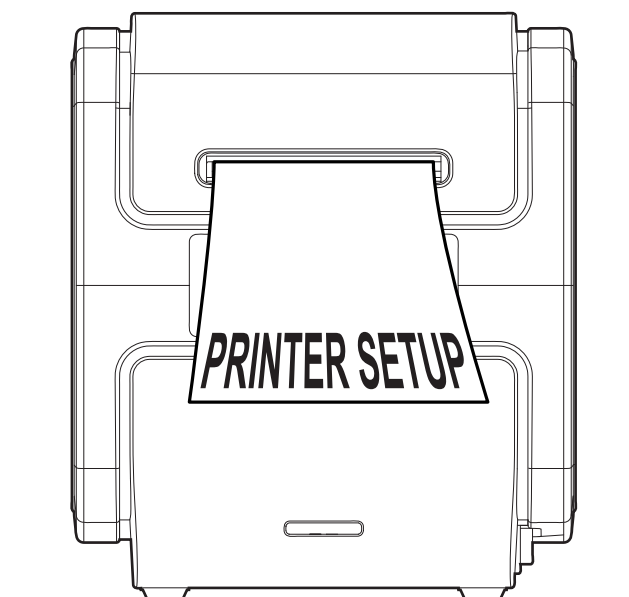
2

The device prints the report with the settings parameters. Follow the instruction printed on the paper to proceed with configuration procedure.



The following figure shows the device setup report. The shown values for parameters are sample values; for a detailed description of the device operating parameters see the following paragraphs.

DEVICE NAME, FIRMWARE MODULES RELEASE and SERIAL NUMBER	}	<p><device name></p> <p>SCODE: <code> - rel 1.00 FCODE: <code> - rel 1.00 DCODE: <code> - rel 1.00</p> <p>S/N: <number></p>
PRINthead STATUS	}	<p>PRINTER SETTINGS</p> <p>1 448</p> <hr style="border-top: 1px dashed black;"/> <p>PRINthead WORKING GOOD!</p>
DEVICE STATUS	}	<p>PRINTER TYPE <device model> INTERFACE USB PROGRAM MEMORY TEST OK DYNAMIC RAM TEST OK CUTTER TEST OK HEAD VOLTAGE [V] = 25.26 HEAD TEMPERATURE [°C] = 22 POWER ON COUNTER = 9 PAPER PRINTED [cm] = 1290 CUT COUNTER = 13 DATE-TIME = <date> <time></p>
PRINTER PARAMETERS	}	<p>Printer Emulation : CUSTOM/POS RS232 Baud Rate : 115200 bps RS232 Data Length : 8 bits/chr RS232 Parity : None RS232 Handshaking : Xon/Xoff Busy Condition : RxFull Chars / inch : A=15 B=20cpi USB Class : Printer USB Address Number : 0 Print Mode : Normal Autofeed : Disabled Speed / Quality : High Speed Paper Width : 54 mm Black mark Position : Bottom Autodetect Jam : Disabled Autoload No Recovery : Disabled Low Paper : Disabled Paper Threshold : 40% Black mark Threshold : 60% Black mark Distance [mm] : +00.0 Black mark Min. Width : 0 mm Ticket Locking : Disabled Ticket Management : Disabled PaperEnd Buffer Clear : Disabled Font Type : International Code Page [num] : 0 Print Test Head Power On : Disabled Ejector Speed : 100% Print Density : 0%</p>
KEYS FUNCTIONS	}	<p>[LF] <i>enter Printer Setup</i> [LF+FF] <i>enter Clock Setup</i> [FF] <i>skip Setup</i></p>



6.2 Configuration by software

The setup parameters can be set by using the “PrinterSet” software tool available on www.custom4u.it. For a detailed description of the device operating parameters see the following paragraphs. To configure the device by software, proceed as follows:

1

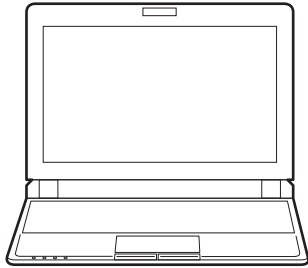

Connect the device to a PC directly (see paragraph 4.3), without using HUB devices.

2

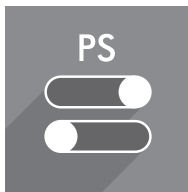

Start “PrinterSet” software tool.

3

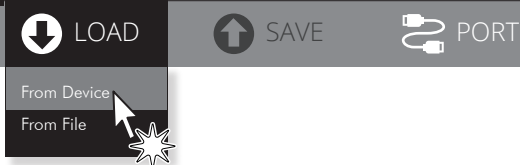

Click on LOAD > FROM DEVICE and select the device connected to the PC.

4

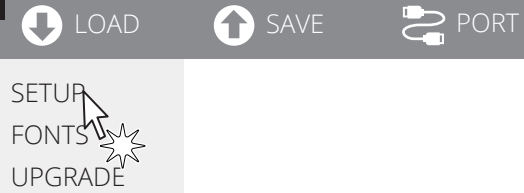

Click on SETUP to access the operating parameters of the device to be configured.

5

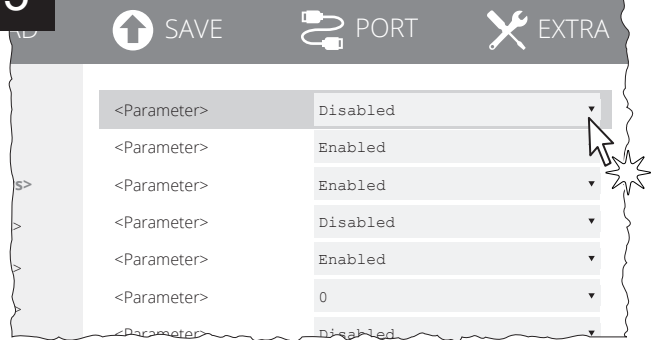

Make the desired changes to the device operating parameters.

6

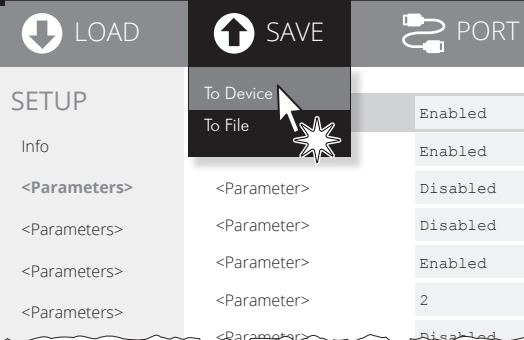

Click on SAVE > TO DEVICE to make the changes made effective.

ATTENTION:

During saving, it is strongly discouraged to disconnect the communication cable or to remove the power supply of the PC or the device.

6.3 Configuration by file

The setup parameters can be set by editing the "Setup.ini" file stored on the Flash Drive of the device. Proceed as follows:

1

↓

Enter setup

Enter the configuration procedure by keys (see [paragraph 6.1](#)) or by software (see [paragraph 6.2](#)).

2

<parameter> : <value>
<parameter> : <value>
<parameter> : <value>
<parameter> : <value>
USB Class : Mass Storage
<parameter> : <value>
<parameter> : <value>
<parameter> : <value>
<parameter> : <value>

Check that the "USB Class" parameter is set to "Mass Storage". Otherwise, this configuration mode is not available.

3

USB

↓

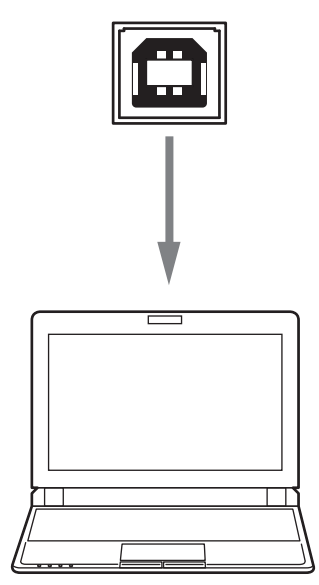

Plug the device to a Personal Computer via USB.

4

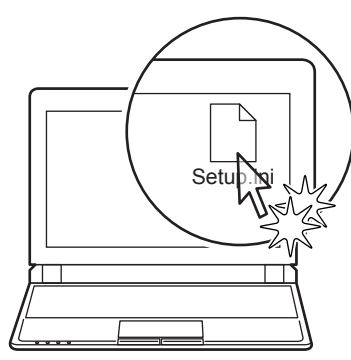

Enter the Flash drive of the device and edit the "Setup.ini" file.

The "Setup.ini" file is a configuration file that contains all the configurable parameters listed in text format and divided into some sections (indicated between square brackets). For each parameter, you find the parameter name followed by the value currently set and then the available values listed with a reference number. The reference number marked with the symbol ' * ' is the default one (see figure).

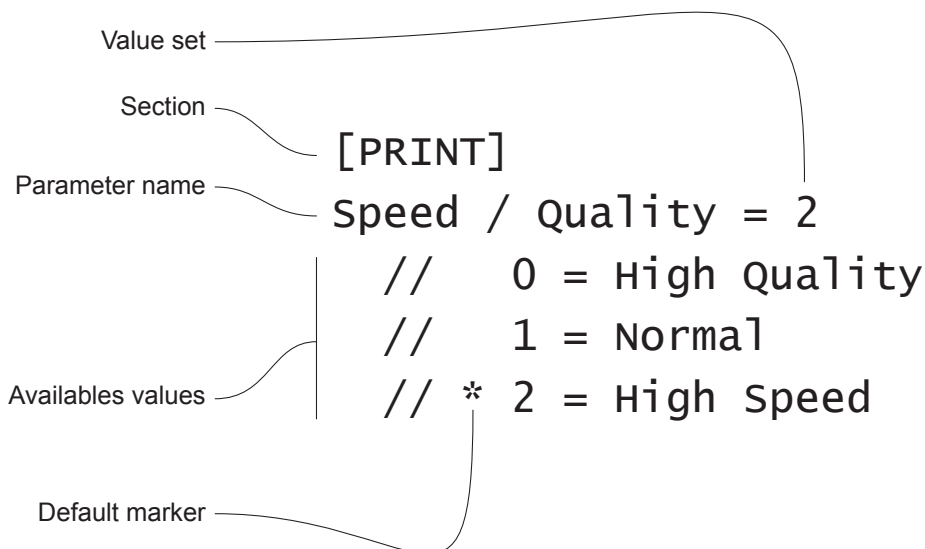

To modify the parameter, change the numeric value after the parameter name or use the default value by typing "D". After editing device's parameter, simply save the "Setup.ini" file to make the modifies activated. For a detailed description of the device operating parameters see the following paragraphs.

ATTENTION:

The change of value for the "USB Class" parameter may compromise the access to the Setup.ini file. Be careful to keep the "Mass Storage" value to allow a new access to the Flash Drive.



6.4 Printhead status

The device performs the printhead operating status when printing the setup report. The total number of dots is reported. Are indicated the total dots number of the printhead and their status (see figure below).

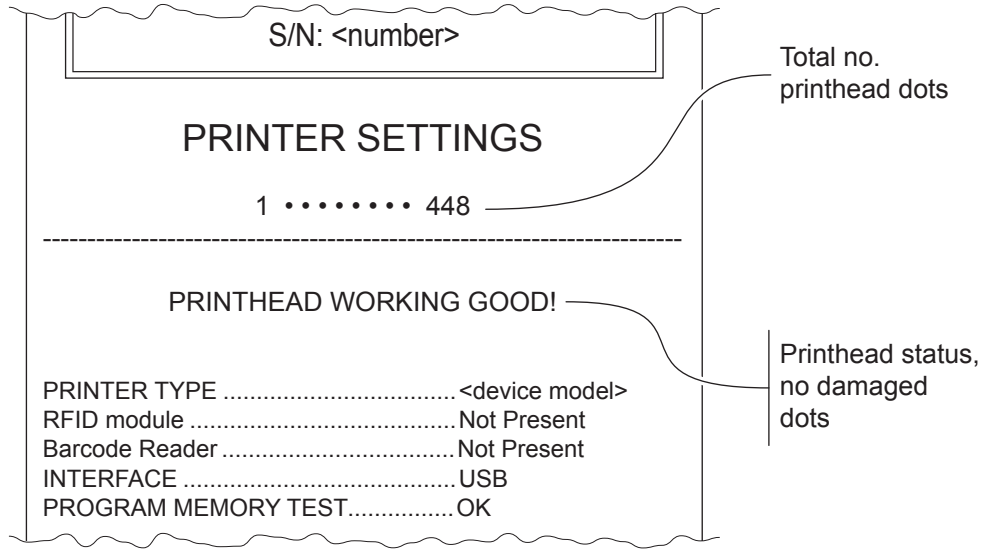

In case of damaged dots, these are listed in the print out in according to their position on the heating line (see figure below).

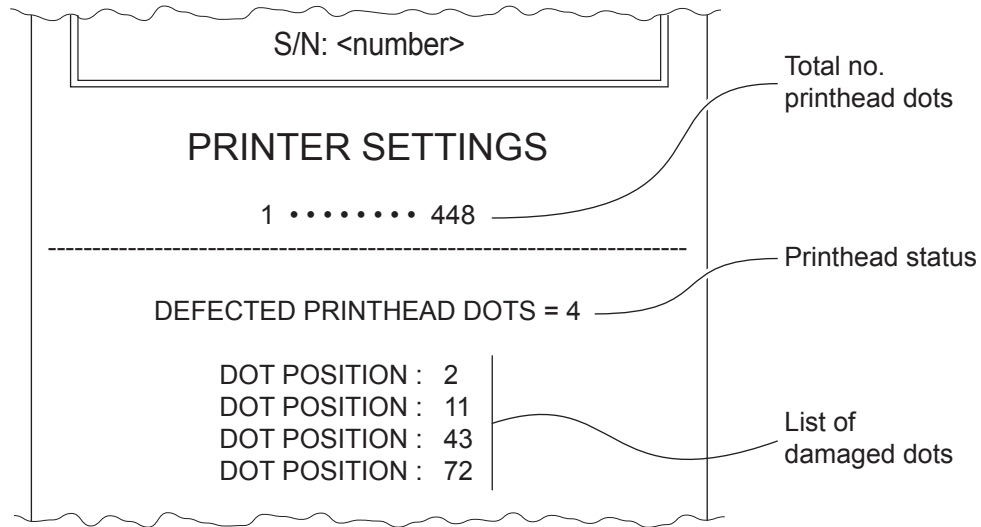



6.5 Device status

The device operating status is indicated in the configuration print-out in which, next to the name of the components displayed, the following information is given:

PRINTER TYPE	device model
INTERFACE	interface present
PROGRAM MEMORY TEST	OK appears if functioning and NOT OK if faulty
DYNAMIC RAM TEST	OK appears if functioning and NOT OK if faulty
CUTTER TEST	OK appears if functioning and NOT OK if faulty
HEAD VOLTAGE	voltage of the head
HEAD TEMPERATURE	temperature of the head
POWER ON COUNTER	number of power-ups made
PAPER PRINTED	centimetres of paper printed
CUT COUNTER	number of cuts made
DATE - TIME	date and time of the device



6.6 Communication parameters

These devices allow the configuration of the parameters listed in the following table. The parameters marked with the symbol ^D are the default values. Settings remain active even after the device has been turned off and they are stored in non-volatile memory.

RS232 BAUD RATE	Communication speed of the serial interface: 115200 ^D 38400 9600 57600 19200 This parameter is valid only with serial interface.
RS232 DATA LENGTH	Number of bit used for characters encoding: 8 bits/car ^D 7 bits/car This parameter is valid only with serial interface.
RS232 PARITY	Bit for the parity control of the serial interface: None ^D = parity bit omitted Even = even value for parity bit Odd = odd value for parity bit This parameter is valid only with serial interface.
RS232 HANDSHAKING	Handshaking: XON/XOFF ^D = software handshaking Hardware = hardware handshaking (CTS/RTS) This parameter is valid only with serial interface. When the receive buffer is full, if handshaking is set to XON/XOFF, the device sends the XOFF (0x13) on the serial port. When the receive buffer has cleared once again, if handshaking is set to XON/XOFF, the device sends the XON (0x11) on the serial port.
BUSY CONDITION	Activation mode for Busy signal: OffLine/ RXFull = Busy signal is activated when the device is both in OffLine status and the buffer is full RXFull ^D = Busy signal is activated when the buffer is full This parameter is valid only with serial interface.
USB CLASS	USB communication class definition. Printer ^D = setting the printer function Mass Storage = setting the sharing mode from Mass Storage Virtual COM = setting the USB port as a virtual serial port To use the “Virtual COM” value, it is necessary to install an additional driver (see paragraph 4.5).



USB ADDRESS NUMBER

Numerical address code for the univocal identification of the USB device (in case of more than a USB device connected with the same PC):

0 ^D	2	4	6	8	
1	3	5	7	9	None

If this parameter is set to None it is Windows that automatically identifies the USB devices connected to the PC in a univocal way adding the suffix copy 1, copy no.



6.7 Operation parameters

These devices allow the configuration of the parameters listed in the following table.

The parameters marked with the symbol ^D are the default values.

Settings remain active even after the device has been turned off and they are stored in non-volatile memory.

PRINTER EMULATION	Available emulations for the device: CUSTOM/POS SVELTA ^D
--------------------------	---

AUTOLOAD NO RECOVERY	This parameter, if enabled, does not perform the paper recovery mode after autoloading. Disabled ^D = performs the paper recovery mode after autoloading Enabled = does not perform the paper recovery mode after autoloading It is possible to use this feature only if the option "Paper Recovery Mode" is set to "Recovery at start page" into the driver properties.
-----------------------------	---

AUTOFEED	Setting of the Carriage Return character: Disabled ^D = Carriage Return disabled Enabled = Carriage Return enabled The parameter is printed only with CUSTOM/POS emulation enabled.
-----------------	--

CHARS / INCH	Font selection: A = 11 cpi, B = 15 cpi A = 15 cpi, B = 20 cpi ^D A = 25 cpi, B = 25 cpi CPI = Characters Per Inch The parameter is printed only with CUSTOM/POS emulation enabled.
---------------------	---

PAPER WIDTH	Width of printing area: 20 mm 28 mm 36 mm 44 mm 52 mm 22 mm 30 mm 38 mm 46 mm 54 mm ^D 24 mm 32 mm 40 mm 48 mm 26 mm 34 mm 42 mm 50 mm
--------------------	--

AUTODETECT JAM	This parameter allows to detect the regular alternation of label and gap, in order to avoid serious jams due to curling of the roll or peeling of the labels. The printer stops if the alarm jam occurs. Disabled ^D = automatic detection jam disabled Enabled = automatic detection jam enabled
-----------------------	---

LOW PAPER	Setting the low paper sensor: Disabled ^D = Sensor disabled Enabled = Sensor enabled
------------------	--



TICKET MANAGEMENT This parameter allows the ticket management:

Disabled ^D = no check
 Short Ticket = it is possible to manage tickets with length less than the distance between the black mark sensor and the printing line

PAPEREND BUFFER CLEAR Cleaning mode of the data in receive buffer, if the printing is stopped due to lack of paper:

Disabled ^D = The data remain in the receive buffer. When the paper runs out, the device keeps the remaining data in the receive buffer and prints the remaining portion of the ticket after that the new paper is loaded.
 Enabled = When the paper runs out, all data in the receive buffer are deleted.

FONT TYPE Setting of the font type:

International ^D = Enables the use of the 256 characters font tables
 Chinese GB18030 = Enables the use of the chinese extended font GB18030-2000
 Korean CP949 = Enables the use of the korean font CP949

When the “International” font is enabled, you need to choose the character code table (“Code Page” parameter). When the Chinese or Korean fonts is enabled, the selection of the character code table is suspended (“Code Page” parameter).

CODE PAGE [num] Identifier number of the character code table to use.
 The numeric value of the identifier is made up with the following two parameters for the setting of two digits for the tens and the units:

	Setting the digit for tens:						
Code Page [num x 10]	<table style="margin-left: auto; margin-right: auto;"> <tr> <td style="padding-right: 20px;">0 ^D</td> <td style="padding-right: 20px;">2</td> <td>4</td> </tr> <tr> <td>1</td> <td>3</td> <td>5</td> </tr> </table>	0 ^D	2	4	1	3	5
0 ^D	2	4					
1	3	5					

	Setting the digit for units:										
Code Page [num x 1]	<table style="margin-left: auto; margin-right: auto;"> <tr> <td style="padding-right: 20px;">0 ^D</td> <td style="padding-right: 20px;">2</td> <td style="padding-right: 20px;">4</td> <td style="padding-right: 20px;">6</td> <td>8</td> </tr> <tr> <td>1</td> <td>3</td> <td>5</td> <td>7</td> <td>9</td> </tr> </table>	0 ^D	2	4	6	8	1	3	5	7	9
0 ^D	2	4	6	8							
1	3	5	7	9							

See the [paragraph 9.10](#) to learn about the character tables corresponding to the identification numbers set with this parameter.
 The character tables set with this parameter are the same set with the command 0x1B 0x74 (refer to the commands manual of the device).

PRINTHEAD TEST POWERON Setting of the performing of the print head test:

Disabled ^D = the test is performed only during the printing of the setup report
 Enabled = the test is performed at each power on

PRINT DENSITY Adjusting the printing density:

-25% -12% 0 ^D +12% +25%

The print quality is strongly influenced by the type of chemical treatment and the type of storage to which the thermal paper has been subjected, as well as by the weight of the same. It may therefore necessary to act on this parameter to obtain the desired print quality.



PRINT MODE	Printing mode: Normal ^D = enables printing in normal writing way Reverse = enables printing rotated 180 degrees
SPEED / QUALITY	Setting of printing speed and printing quality: Normal High Quality High Speed ^D
PAPER THRESHOLD	Threshold value (in percent) for the recognition of the presence of paper by the paper presence sensor: 30% 60% 90% 40% ^D 70% 50% 80%
EJECTOR SPEED	Setting the ejector speed. 25% 75% 50% 100% ^D This parameter is valid only for models with optional plastic motorized kit ejection/retention ticket (see chapter 11).
TICKET X DIMENSION	Length in mm of the ticket to print 152 ^D The parameter is printed only with SVELTA emulation enabled.
TICKET OFFSET X	Fixed offset in mm of horizontal positioning of the ticket to be printed 0 ^D The parameter is printed only with SVELTA emulation enabled.
TICKET OFFSET Y	Fixed offset in mm of vertical positioning of the ticket to be printed 0 ^D The parameter is printed only with SVELTA emulation enabled.



6.8 Alignment parameters

These devices allow the configuration of the parameters listed in the following table.

The parameters marked with the symbol ^D are the default values.

Settings remain active even after the device has been turned off and they are stored in non-volatile memory.

BLACK MARK POSITION	Position of the black mark alignment and choice of appropriate black mark sensor:
	Disabled ^D = the black mark alignment is not performed
	Bottom = the black mark position is detected by the lower sensor (reflection)
	Transparent = the black mark position is detected by both the sensors (transparence)
	Top = the black mark position is detected by the upper sensor (reflection)

BLACK MARK THRESHOLD	Threshold value (in percent) for the recognition of the presence of black mark by the black mark sensor:
	30% 70%
	40% 80%
	50% 90%
	60% ^D

If the “Black Mark Position” parameter is disabled, this parameter is not printed.

BLACK MARK DISTANCE	“Black Mark Distance” is the minimum distance (in mm) between the upper edge of ticket and the black mark (see chapter 7). The numeric value of the distance is made up with the following four parameters for the setting of three digits (two for the integer part of the number and one for the decimal part) and of the sign:
----------------------------	---

	Sign setting:
BLACK MARK DISTANCE SIGN	+ ^D = positive distance
	- = negative distance

	Setting the digit for tens:
BLACK MARK DISTANCE [mm x 10]	0 ^D 2 4 6 8
	1 3 5 7 9

	Setting the digit for units:
BLACK MARK DISTANCE [mm x 1]	0 ^D 2 4 6 8
	1 3 5 7 9

	Setting the digit for decimals:
BLACK MARK DISTANCE [mm x .1]	0 ^D 2 4 6 8
	1 3 5 7 9



For example, to set a positive black mark distance value of 15mm, modify the parameters as follows:

Black Mark Distance Sign = +
 Black Mark Distance [mm x 10] = 1
 Black Mark Distance [mm x 1] = 5
 Black Mark Distance [mm x .1] = 0

If the “Black Mark Position” parameter is disabled, the parameters for the “Black Mark Distance” are not printed.

**BLACK MARK
MIN. WIDTH**

Minimum length for the black mark alignment:

0 mm ^D	5 mm	10 mm	15 mm	20mm
1 mm	6 mm	11 mm	16 mm	
2 mm	7 mm	12 mm	17 mm	
3 mm	8 mm	13 mm	18 mm	
4 mm	9 mm	14 mm	19 mm	

If the “Black Mark Position” parameter is disabled, this parameter is not printed.

This parameter describes the dimensions of the black mark alignment in order to avoid that other graphics on the ticket is detected erroneously as a black mark

TICKET LOCKING

This parameter enables/disables the block of the paper inside the device where the ticket is not cut with the autocutter, but is presented for the manual tear off by the user:

Disabled^D = paper block disabled
 Enabled = paper block enabled

If the “Black Mark Position” parameter is disabled, the parameter is not printed.



6.9 Hexadecimal dump

This function is used for the diagnosis of the characters received from the communications port. Characters are printed as hexadecimal code and the corresponding ASCII code (see below). Each line is preceded by a counter in hexadecimal that indicates the number of bytes received.

During the startup, if you hold down the LF LINE FEED key, the device enters the self-test routine and print the setup report. The printer remains in standby until a key is pressed or characters are received through the communication port (Hexadecimal Dump mode). For each character sent, the ticket shows the hexadecimal value and the ASCII codes (if the characters are underlined, the receive buffer is full). Shown below is an example of a Hexadecimal Dump:

```

                                HEXADECIMAL DUMP

31 32 33 34 35 ...      12345 ...
39 30 31 32 33 ...      90123 ...
37 38 39 75 69 ...      789ui ...
68 6B 6A 73 64 ...      hkjsd ...
73 64 66 6B 6A ...      sdfkj ...
66 73 64 66 6B ...      fsdfk ...
65 69 6F 79 75 ...      eioyu ...
6F 72 69 75 77 ...      oriuw ...
6F 75 77 65 72 ...      ouwer ...
77 65 72 69 6F ...      werio ...
72 69 6F 75 77 ...      riouw ...
6B 6C 73 64 66 ...      klsdf ...
64 66 6B 73 64 ...      dfksd ...
73 64 66 6B 6A ...      sdfkj ...
66 6B F2 6A 73 ...      fk≥j ...
6A 6B 6C 68              jklh
```



6.10 Calendar clock

The devices are equipped with a Real Time Clock. During power-up, held down the LF LINE FEED key to enter in the printer configuration mode. Pressing both the LF and FF keys to enter in the clock configuration (see following figure). Press the LF LINE FEED key to modify date/time; the device will print the updated date and time.

Follow the instructions printed on the paper for the key functionality. The highlighted digit (the number is written in negative mode) indicates the digit to be modified. Press the LF LINE FEED key to modify the value of the highlighted digit; every single LF LINE FEED key pressure increases of 1 his value. Once the value 9 is reached the counting starts again from 0.

Press the FF FORM FEED key to move the cursor on the next digit; if the cursor position is on the latest digit you can proceed to next parameter by pressing the FF FORM FEED key again.

CLOCK SETUP

[LF] to modify date/time
[FF] to next field

0 1/01/21	12:00:00
0 1 /01/21	12:00:00
01/ 0 1/21	12:00:00
01/0 1 /21	12:00:00
01/01/ 2 1	12:00:00
01/01/2 1	12:00:00
01/01/21	1 2:00:00
01/01/21	1 2 :00:00
01/01/21	12: 0 0:00
01/01/21	12:0 0 :00
01/01/21	12:00: 0 0
01/01/21	12:00:0 0

Date Time Setting :
01/01/21 12:00:00





7 ALIGNMENT

Device is provided with sensors for the use of alignment black mark in order to handle:

- roll of tickets with pre-printed fields and a fixed length;
- Fan-fold module of tickets with pre-printed fields and a fixed length.

The black mark alignment may be formed by (see [paragraph 9.9](#)):

- black mark printed on paper;
- hole between two tickets;
- gap between two labels.

All alignment sensors are “reflection” sensors: this kind of sensor emits a band of light and detects the quantity of light reflected to it.

The presence of the black mark is therefore detected by the amount of light that returns to the sensor, considering that the light is reflected by the white paper and absorbed by the black mark.

To use tickets with holes or labels with gap, it is possible to use the same sensors as “transparence” sensors, coupled two by two: a beam of light is emitted by the transmitter sensor and the quantity of light which reaches the opposite receiver sensor is detected.

The presence of the hole/gap is detected evaluating the amount of light that arrives to the opposite sensor, considering that the paper doesn't allow the beam of light to reach the receiver, whereas a gap or a hole lets the light to reach the receiver.

The following paragraphs show how to correctly set the configuration parameters of device in order to assure the alignment.

7.1 Enable alignment

Device is provided with two sensors for alignment, placed as follows:

- one mobile sensor on the lower flat
- one sensor on the upper flat.

To guarantee the alignment, it is necessary to correctly choose the sensor to use for the black mark detection depending on the type of black mark and its location on the ticket.

To do this, you must enable the parameter “Black Mark Position” during the setup procedure (see [chapter 6](#)) and set the correct value of this parameter as described in the following table.

SENSOR USED	VALUE OF THE “BLACK MARK POSITION” PARAMETER	USING MODE OF SENSORS	BLACK MARK TYPE
-	Disabled	-	Alignment disabled
1	Bottom	Reflection	Black mark printed on the non-thermal side of paper
2	Top	Reflection	Black mark printed on the lateral thermal side of paper
1 + 2	Transparent	Transparence	Hole between tickets or gap between labels in lateral position

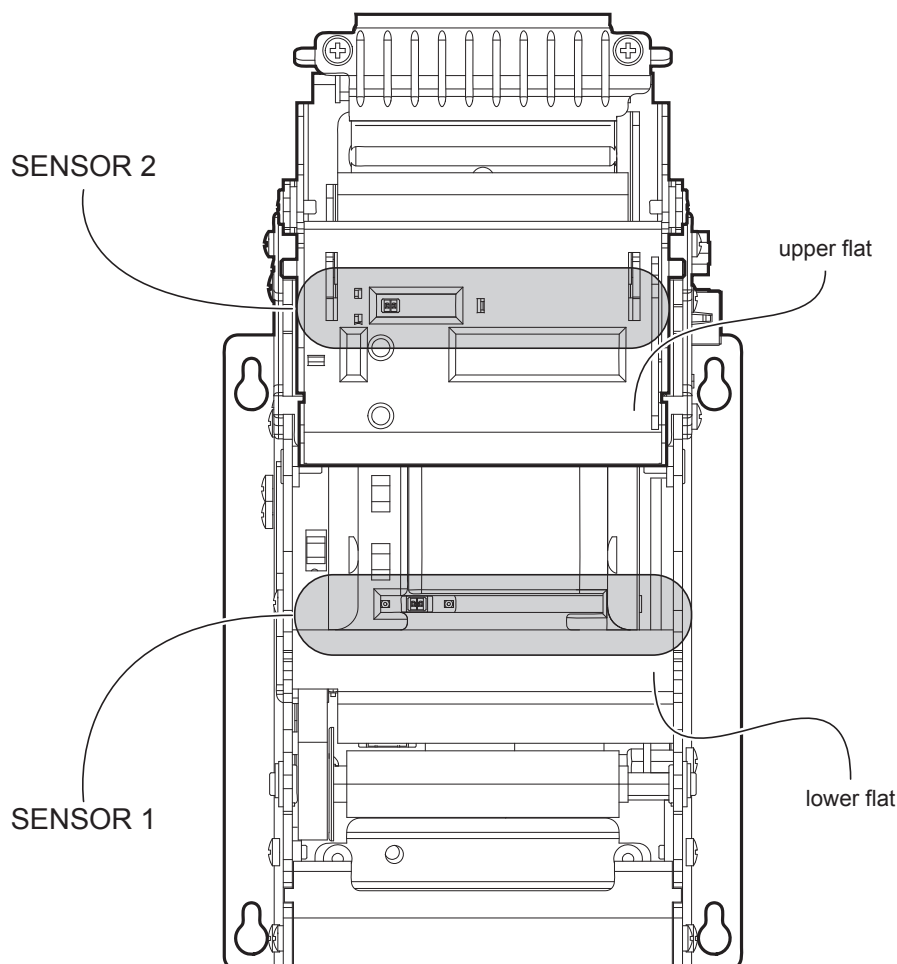

The following figures show the usable format of paper and the corresponding sensors used for alignment:

For ease of understanding, the image shows the two flats represented in the same plane.

For ease of reference, for some models is represented only the internal printer group without the external plastic chassis.

Paper with black mark on the non-thermal side

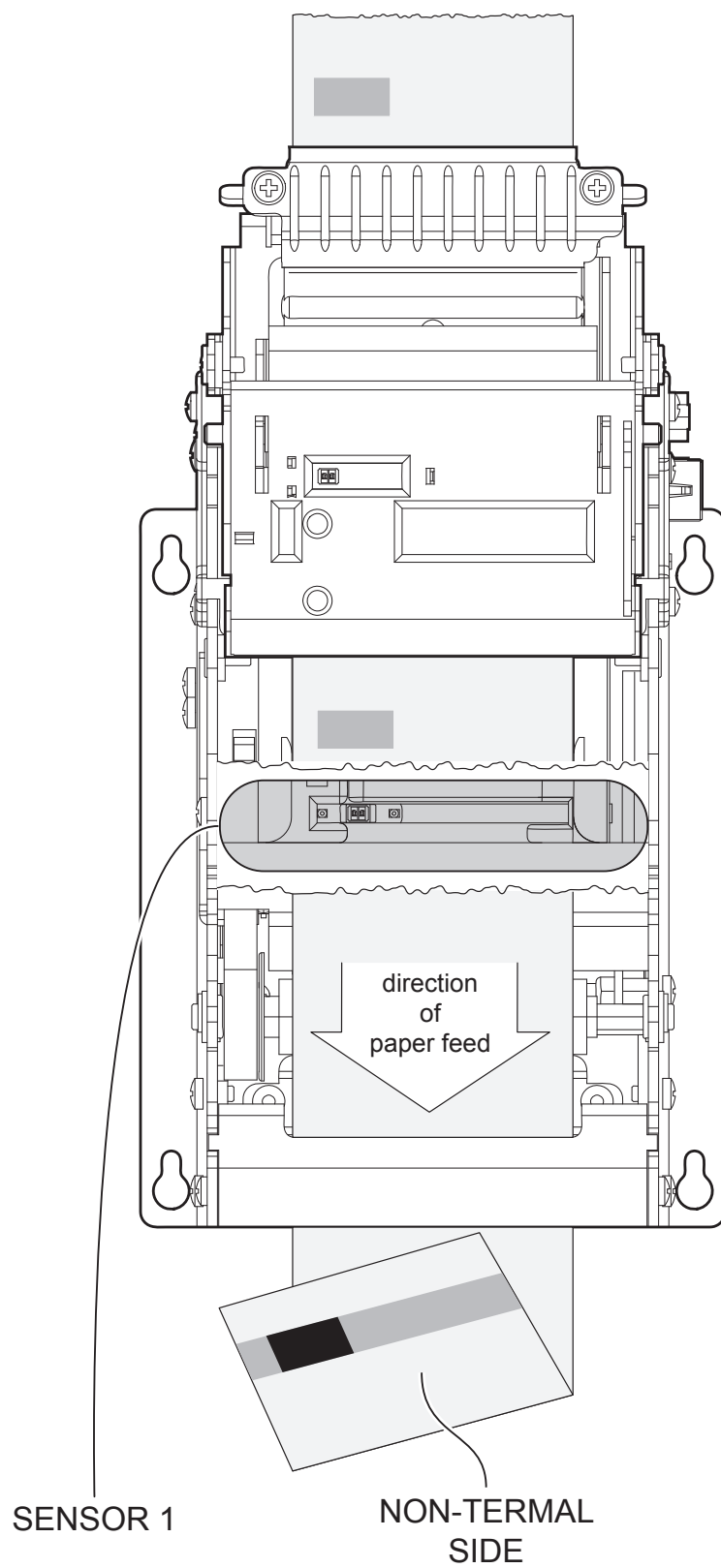



Paper with black mark on the thermal side

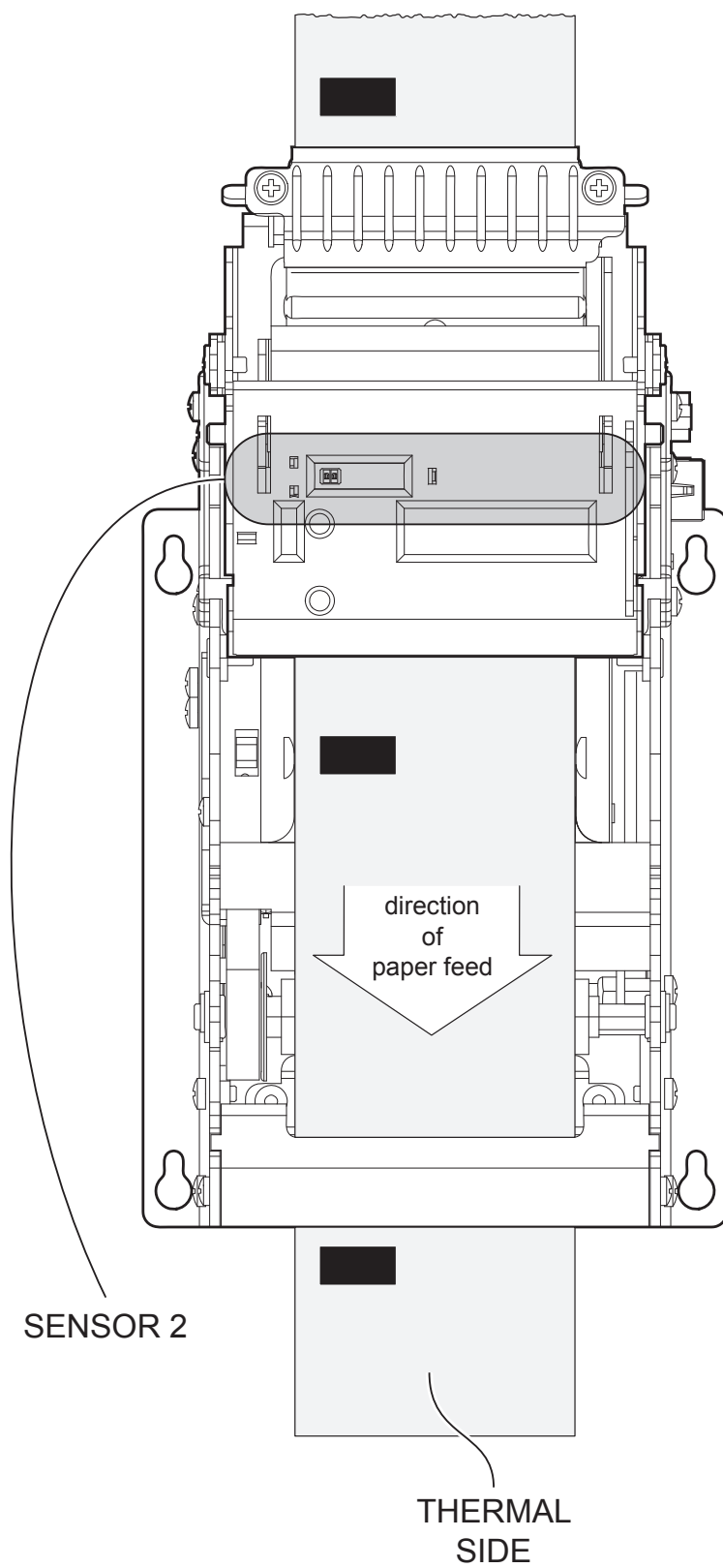

Tickets with hole

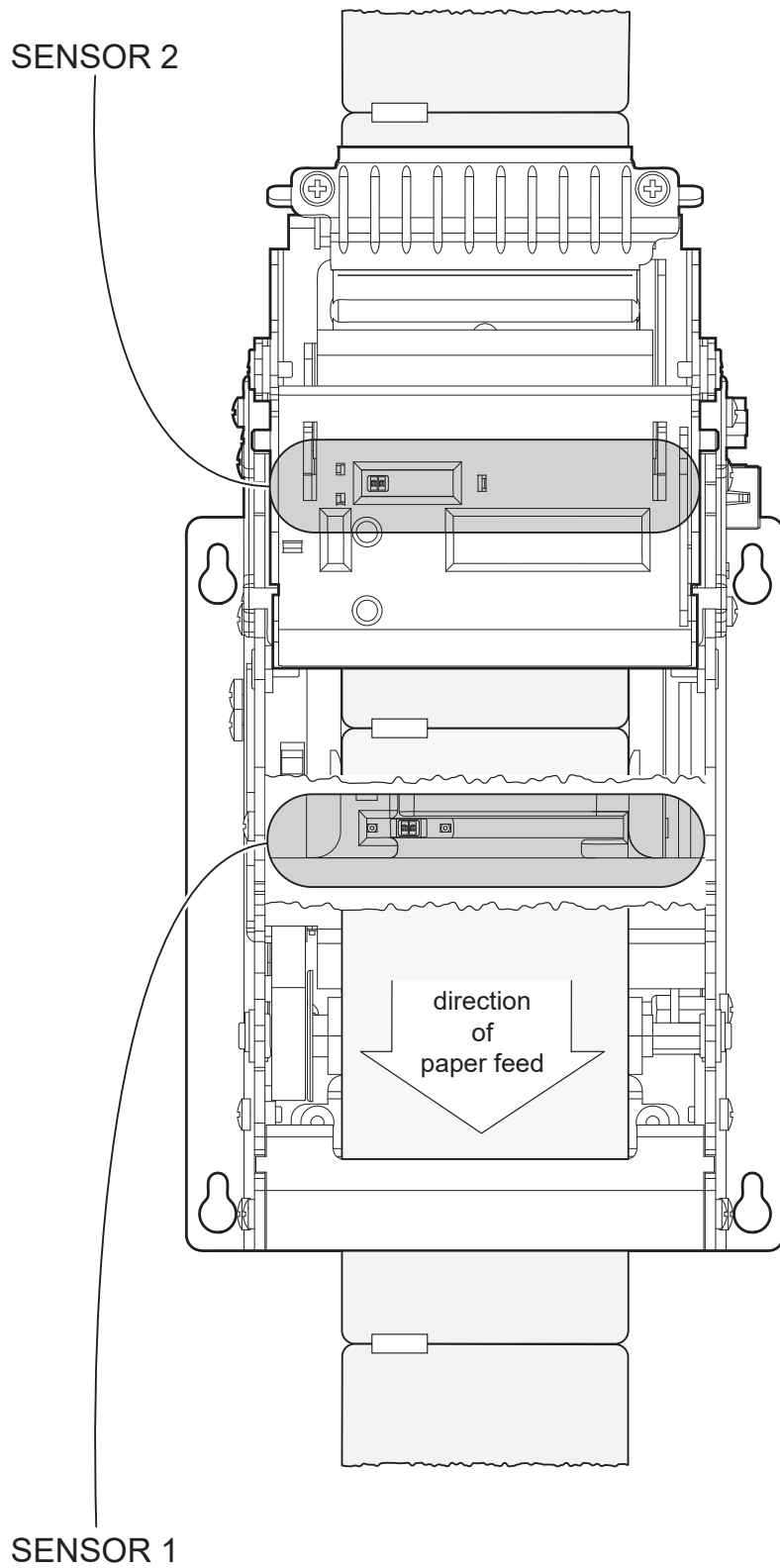



Paper with labels

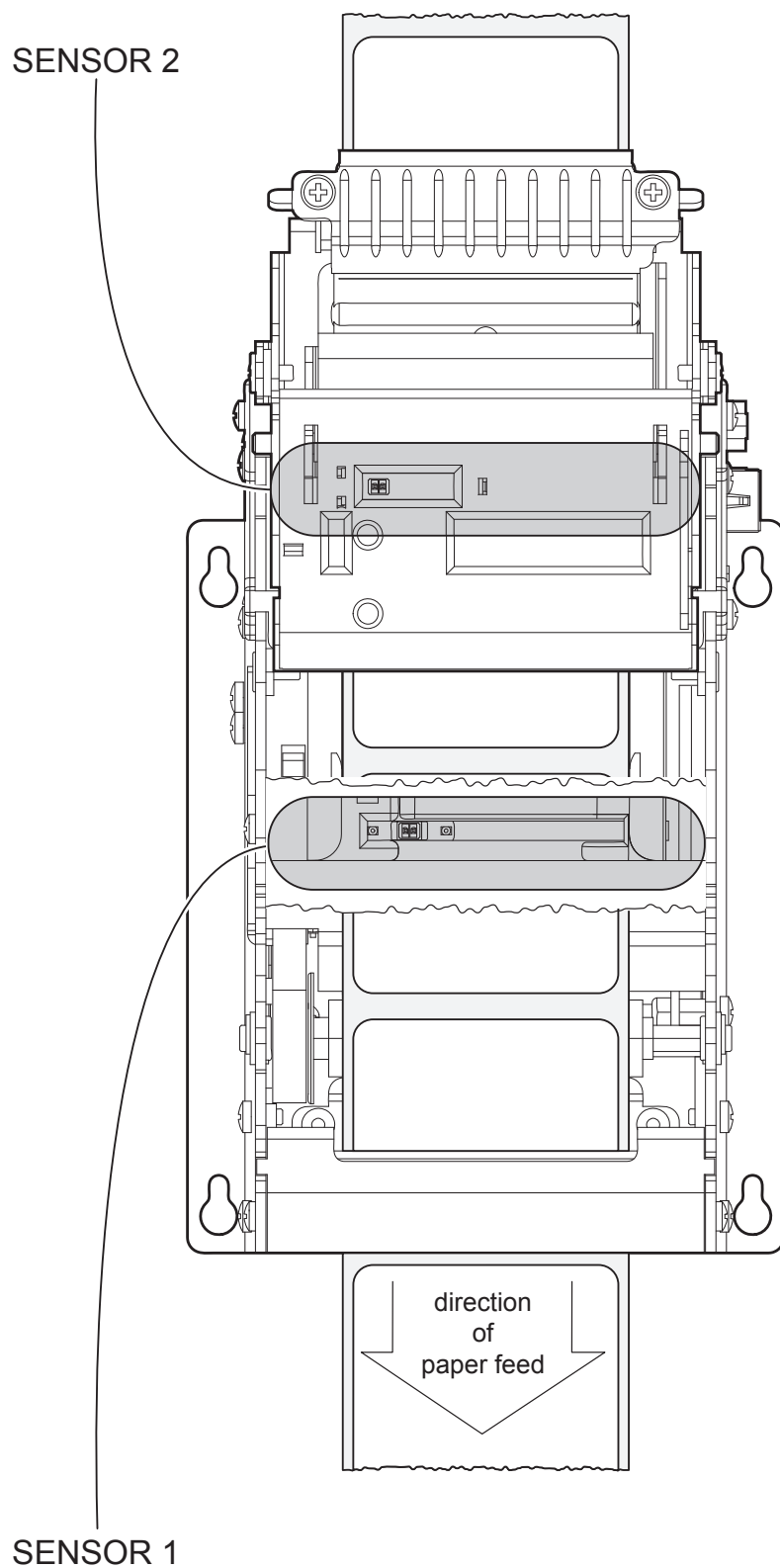

7.2 Calibration

The sensor calibration occurs automatically and consists in adjusting the quantity of light emitted to match the degree of whiteness of the paper used and the degree of black of the mark printed on paper.

The device automatically performs the self-calibration during the setup procedure only if the “Black Mark Position” parameter is set to a value other than “Disabled” (see [chapter 6](#)).

When self-calibration starts, the device performs some paper feeds and then it prints the calibration result and the value of the PWM duty-cycle of the alignment sensor driver so that it can be perform an optimal black mark detection:

```
Autosetting black mark : OK
PWM Duty Cycle : 85.3%
```

The “Autosetting black mark” parameter indicates the result of the self-calibration procedure; OK will appear if it has been successful, NOT OK will appear if the procedure has failed.

After the printing of the procedure result, the device offers the execution of the function of paper characterization “Characterize Paper” and the change of the “Black mark threshold” parameter which represents the detection threshold of the black mark. Choosing the “Yes” value for the “Characterize Paper” parameter, the device prints a graphic representation (see following figures) of the outgoing voltage of the alignment sensor (expressed as a percentage) and the “Black mark threshold” value.

This graphic representation is useful to set the most suitable value to assign to the “Black mark threshold” parameter and then to better identify the optimal threshold value which takes into account the variations of the signal and the small oscillations around zero.

The following figure shows an example of paper with the non-thermal paper printed with black marks: the outgoing voltage is constant while passing the white paper between two black marks and presents a peak at each black mark. In this case, the optimal value for the “Black mark threshold” parameter is placed about half of the peak (as shown in figure).

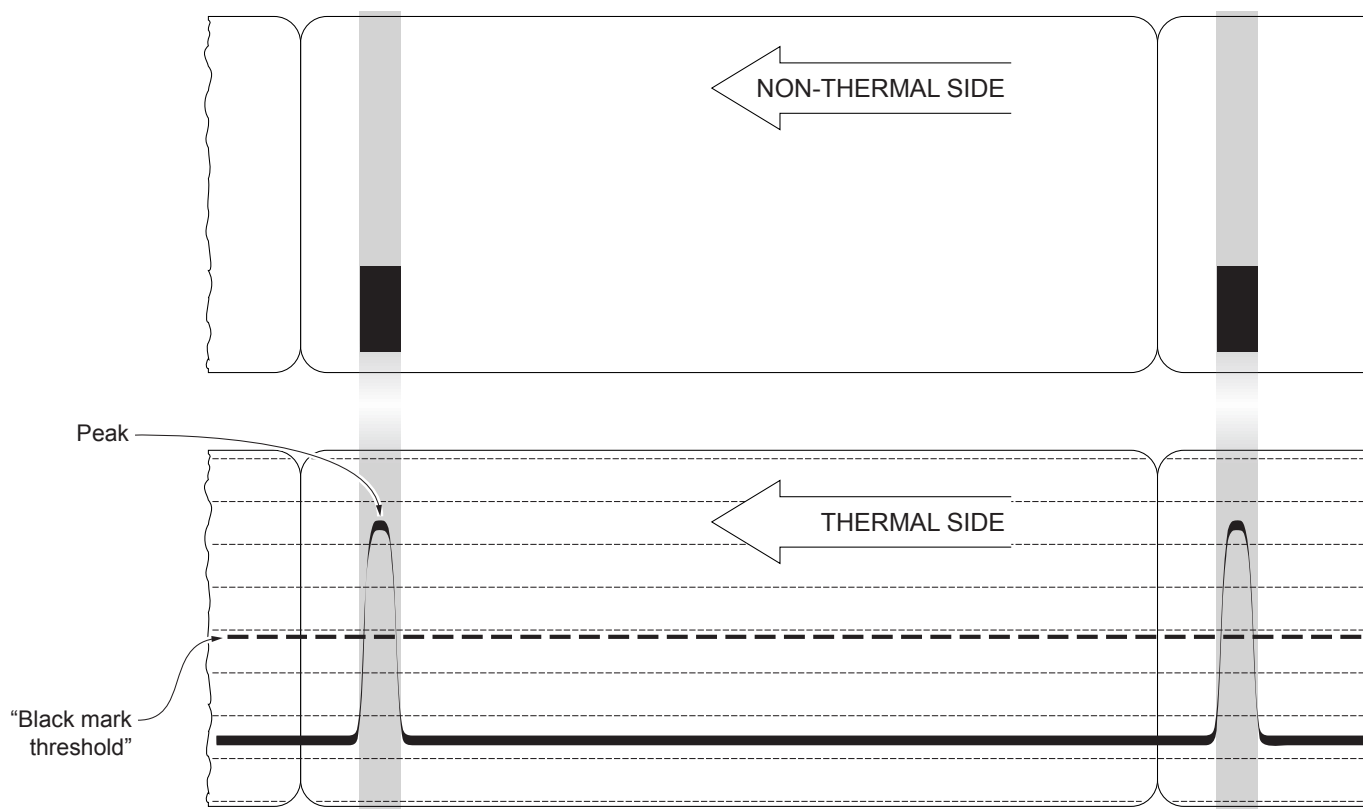



The following figure shows an example of paper with holes: the outgoing voltage is constant while passing the paper between two holes and presents a variation at each hole. In this case, the optimal value for the “Black mark threshold” parameter is placed about half of the variation.

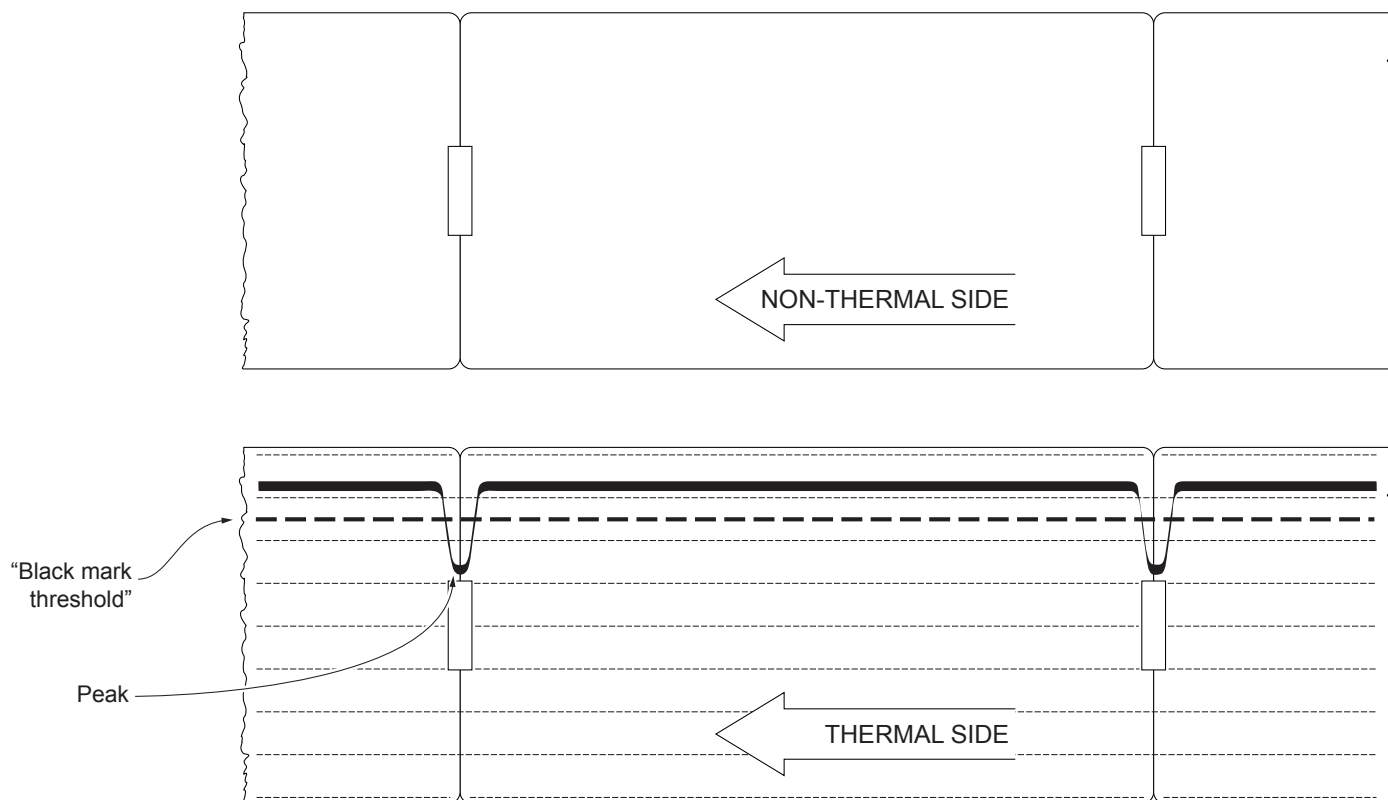



The following figure shows an example of paper with the non-thermal paper printed with black marks and other graphics (for example, a barcode): the outgoing voltage is constant while passing the white paper between two black marks, presents a peak at each black mark and presents some “noise” at each barcode. In this case, the optimal value for the “Black mark threshold” parameter is located about halfway between the peak value and the maximum value of the “noise” (as shown in figure):

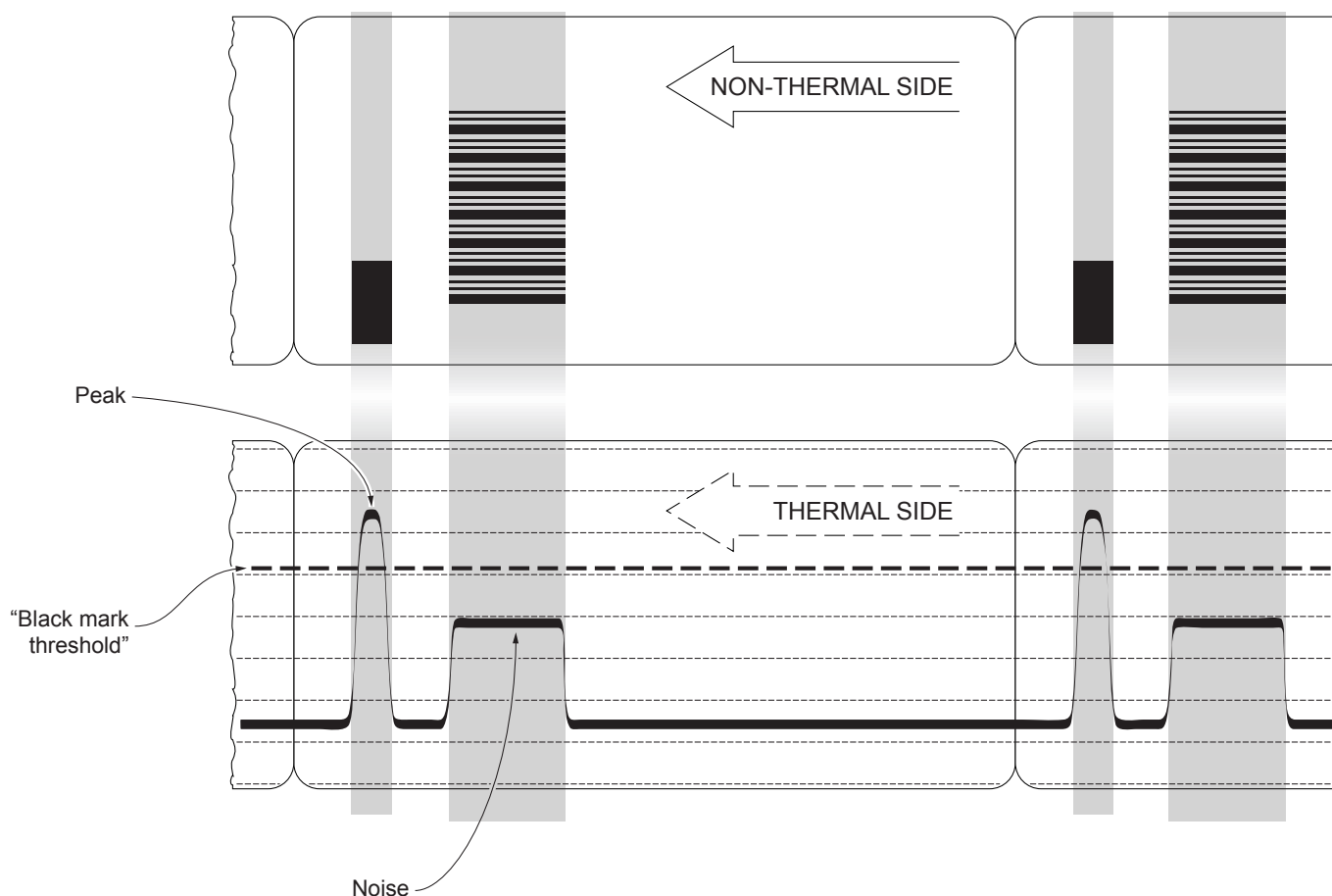

If the maximum value of “noise” read by the sensor is very close to the peak value, it might be difficult to place the value of the “Black mark threshold” at an intermediate point. In these cases, it is mandatory that the portion of paper between the point of printing end and the black mark front is completely white (no graphics). In this way, the only next graphic detected by the sensor for alignment after the printing end will be the black mark.



7.3 Alignment parameters

The “alignment point” is defined as the position inside the ticket to use for the black mark alignment. If you use paper with perforation (Fan-fold modules), the alignment point corresponds with the edge of the ticket. The distance between the black mark edge and the alignment point is defined as “Black Mark Distance”. Referring to the front of the black mark, the value of “Black Mark Distance” can be positive or negative. If the “Black Mark Distance” value is set to 0, the alignment point is set at the beginning of the black mark:

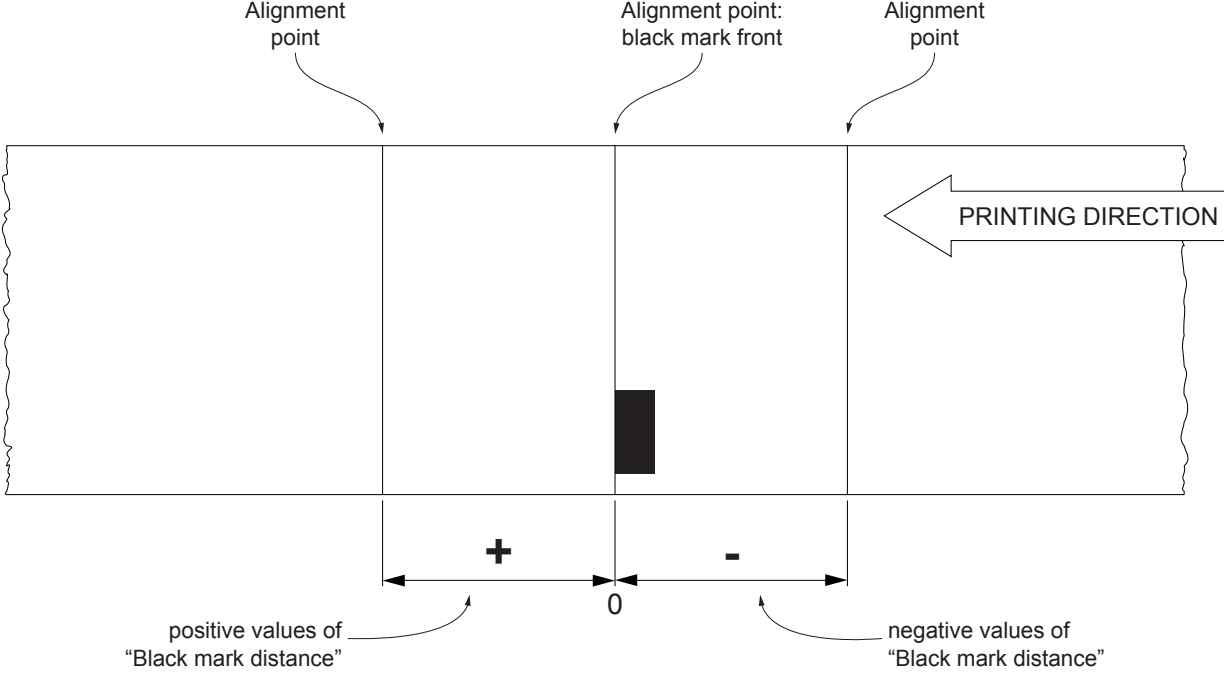

The following figure shows an example of paper with alignment point set by a positive value of “Black Mark Distance” (“Black Mark Distance” = + A):

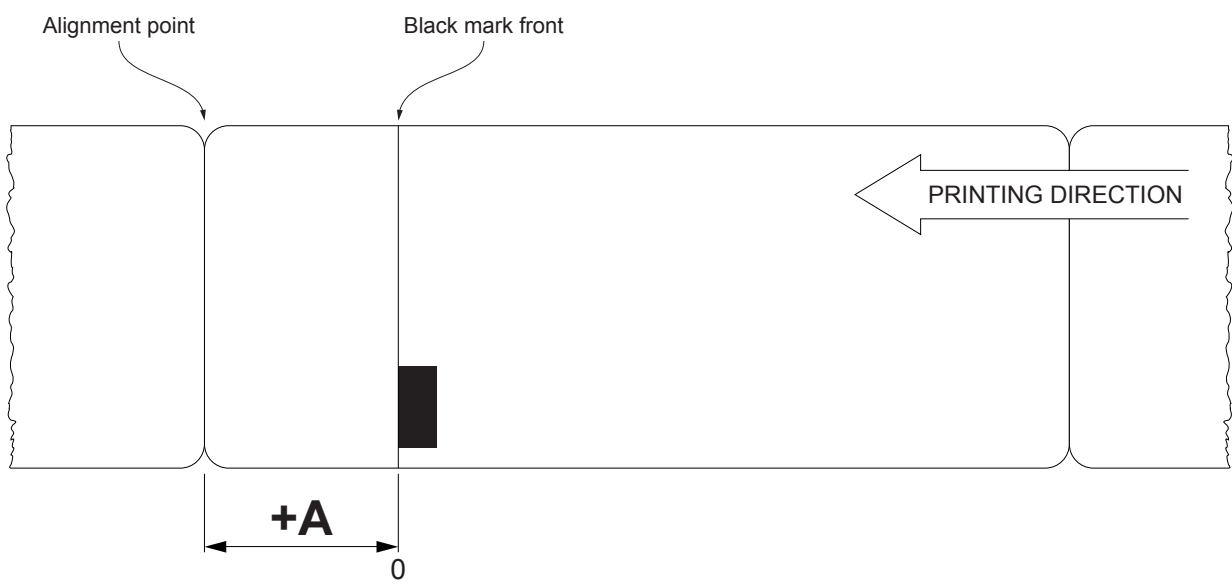

To set a negative value of the “Black Mark Distance” parameter is useful in cases where the alignment point refers to the black mark printed on the previous ticket or where the desired tear-off line is placed in the middle of the black mark alignment (for example, for paper with holes or gap). In the following images, the value of “Black Mark Distance” parameter is set to $-A$.

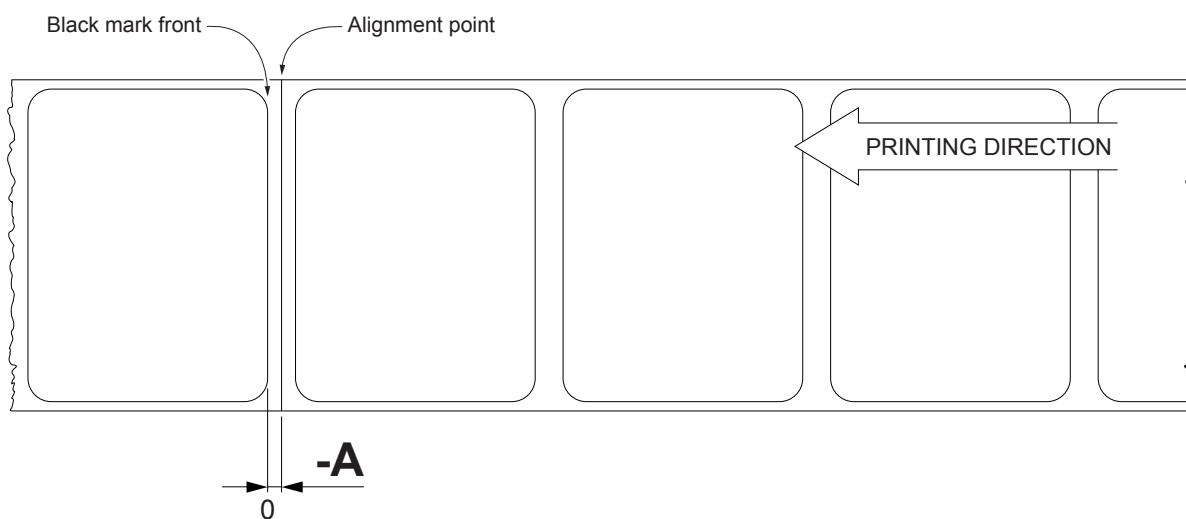
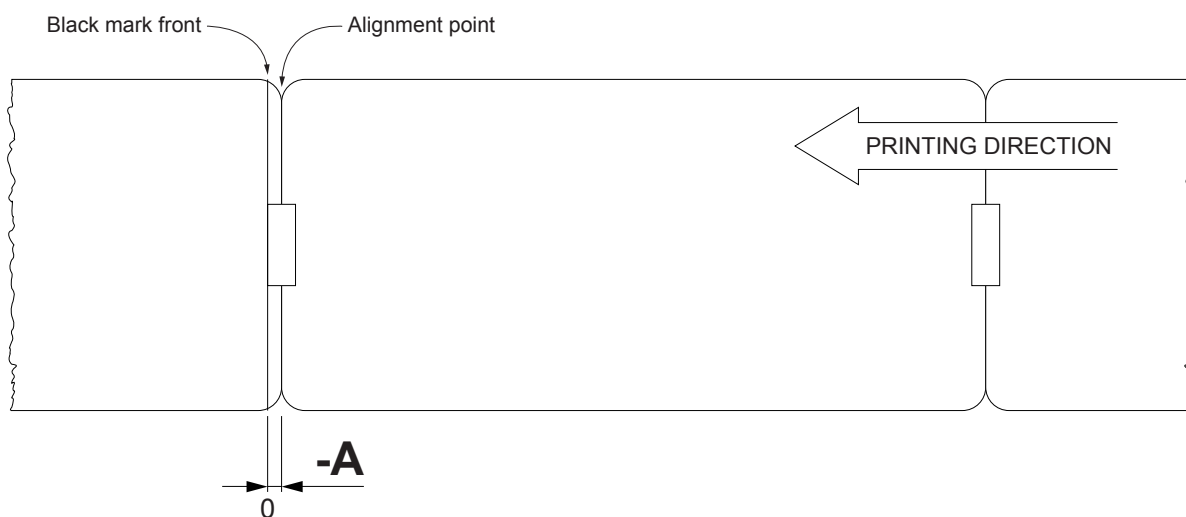
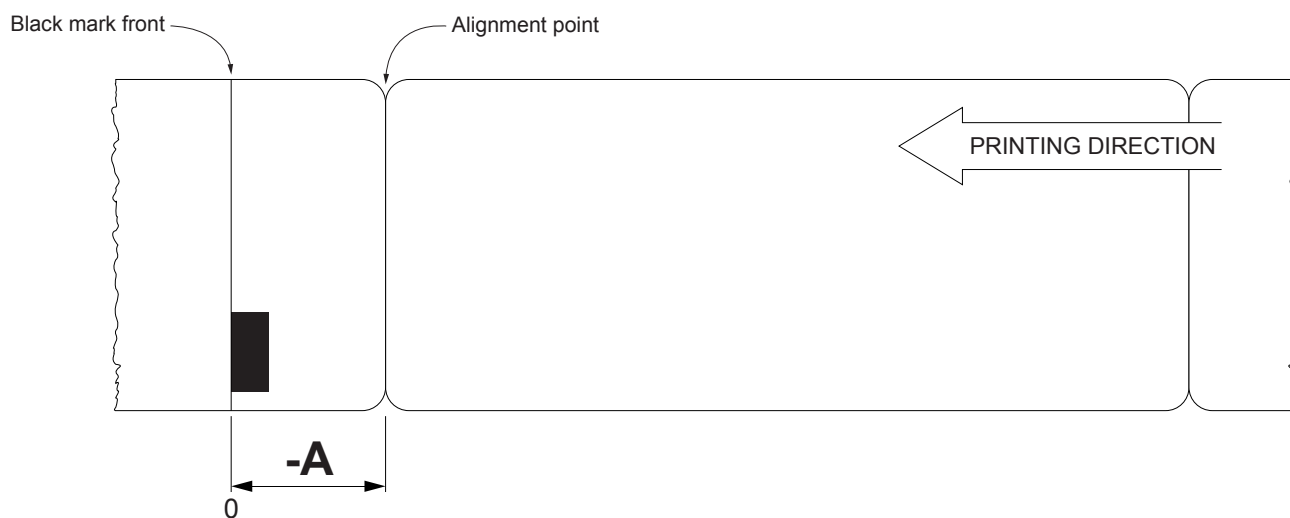



If the black mark is placed on the non-thermal side of paper, the “Black Mark Distance” value can have a minimum value of -5 mm (negative value) and a maximum of 66 mm. This maximum value is imposed by the mechanical distance between the lower black mark sensor and the printing head.

The following figure shows a simplified section of the device with the paper path and the distance (expressed in millimeters) between the alignment sensor, the printing head and the autocutter (cutting line).

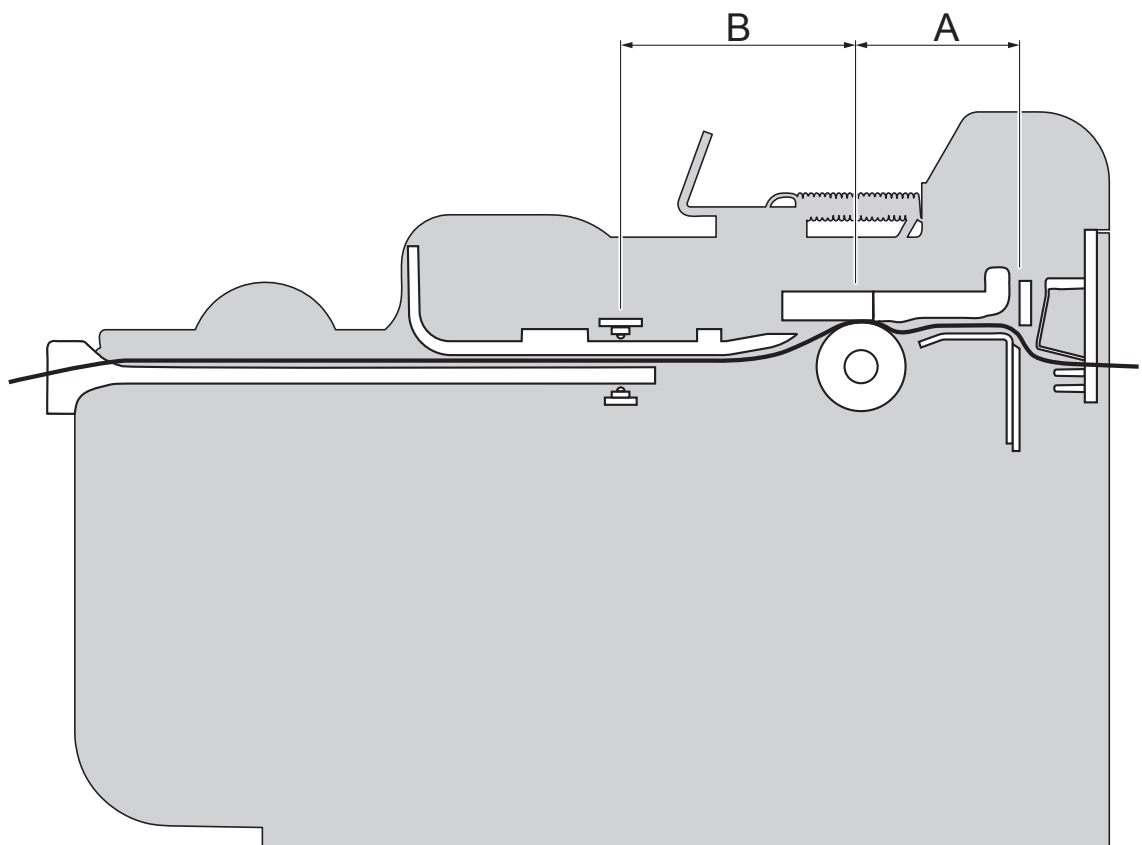

A = 26.5 mm = distance between the cutting line (autocutter) and the printing line (printhead) on paper
B = 39.7 mm = distance between the the printing line (printhead) and the alignment sensor

CUSTOM/POS emulation

To define the alignment point you need to set the printer parameters that compose the numerical value of the “Black Mark Distance” parameter (see [paragraph 6.8](#)).

For example, to set a black mark distance of 15 mm between the black mark and the alignment point, the parameters must be set on the following values:

Black Mark Distance Sign	:	+
Black Mark Distance [mm x 10]	:	1
Black Mark Distance [mm x 1]	:	5
Black Mark Distance [mm x .1]	:	0

The “Black Mark Distance” parameter, may be modified as follows:

- during the setup procedure of the device (see [chapter 6](#))
- by modifying the Setup.ini file (see [paragraph 6.3](#))
- by using the command 0x1D 0xE7 (for more details, refer to the commands manual)
- by driver.

SVELTA emulation

The ticket features and the alignment parameters, may be modified as follows:

- by using the parameters of the <LHT> command (for more details, refer to the commands manual)
- by modifying the Setup.ini file (see [paragraph 6.3](#))
- by driver.

The following figure shows the some of parameters for alignment of the Setup.ini file:

- “Ticket X Dimension”
- “Ticket Y Dimension”
- “Black Mark Width”
- “Black Mark Distance”

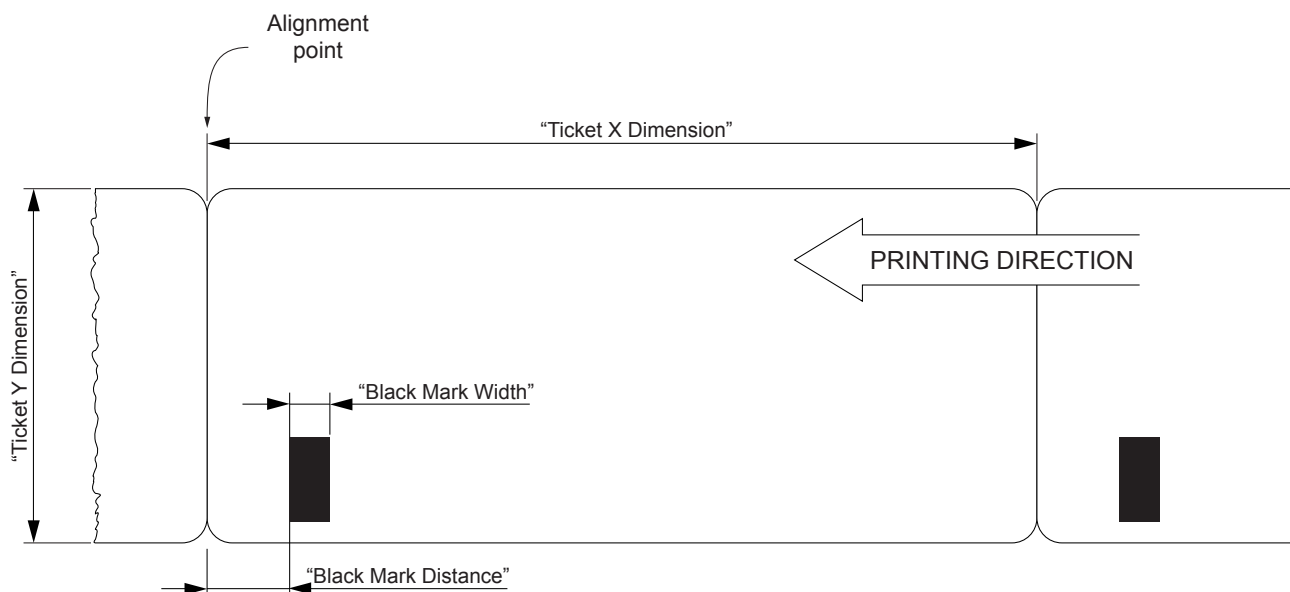

7.4 Printing area

In order to print ticket containing only one black mark and to not overlay printing to a black mark (that will make it useless for the next alignment), it is important to well calibrate the length of the printing area of ticket according to the inter-black mark distance.

The following figure shows an example of tickets with “Black Mark Distance” set to 0:

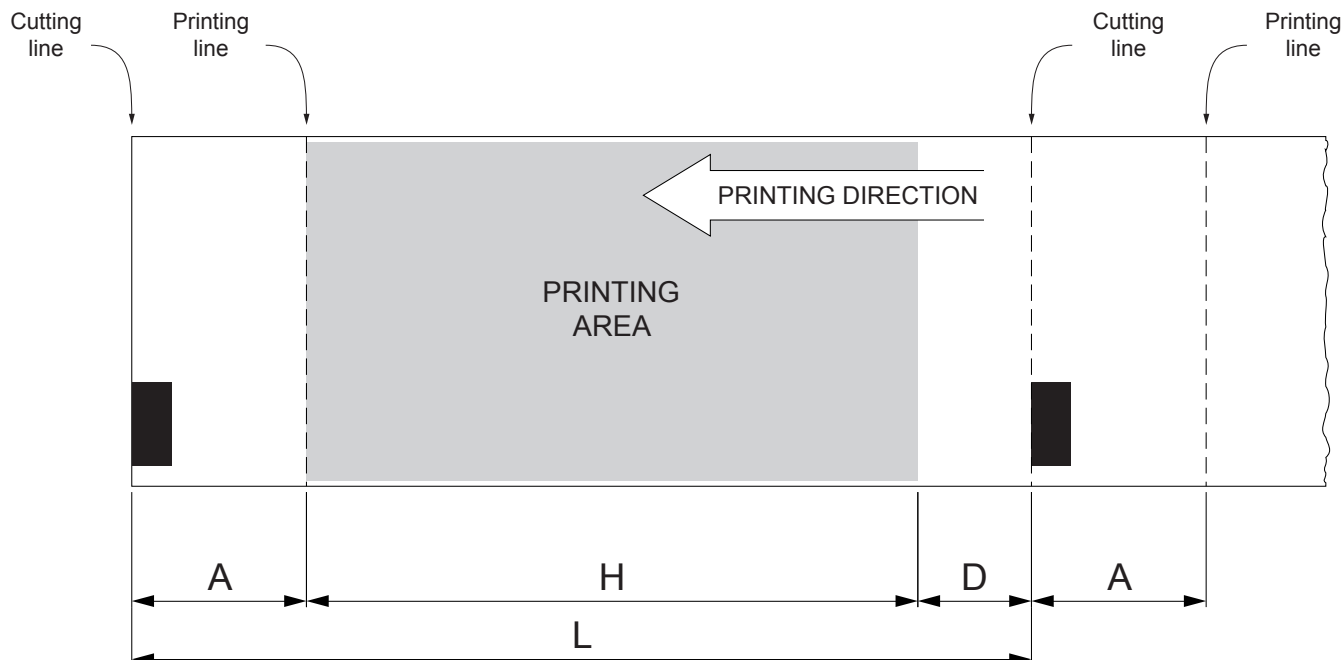

A “Non-printable area” = “Distance between autocutter/printhead”

where:

”Distance between autocutter/printhead” = 26.5 mm

In CUSTOM/POS emulation, after a performed cut, the paper is not completely recovered (in order to avoid jamming when using of thin paper). This decreases the height of the non-printable area : $A = 10\text{mm}$.

Otherwise, in this emulation you can use the command `0x1C 0xC1` to modify the “Value for the paper recovery after a performed cut” (see commands manual).

The SVELTA emulation, instead, it is designed specifically for ticketing and then for using with heavy paper, which avoids the risk of paper jams. After performing a cut, the device completely recovers the paper and therefore the distance of recovery after cutting does not generate non-printable areas: $A = 0$.

H Distance between the first and the last print line, called “Height of the printing area”.

L Distance between an edge of the black mark and the next one, called “Inter-black mark distance”.

D Automatic feed for alignment at the next black mark.

To use all the black marks on paper, you must comply with the following equation:

$$H + A \leq L$$

The height of the printing area (H) can be increased to make no progress on alignment (D) but no further.



8 MAINTENANCE

8.1 Printer paper jam

For ease of reference, in some figures is represented only the internal printer without the external plastic chassis.

1

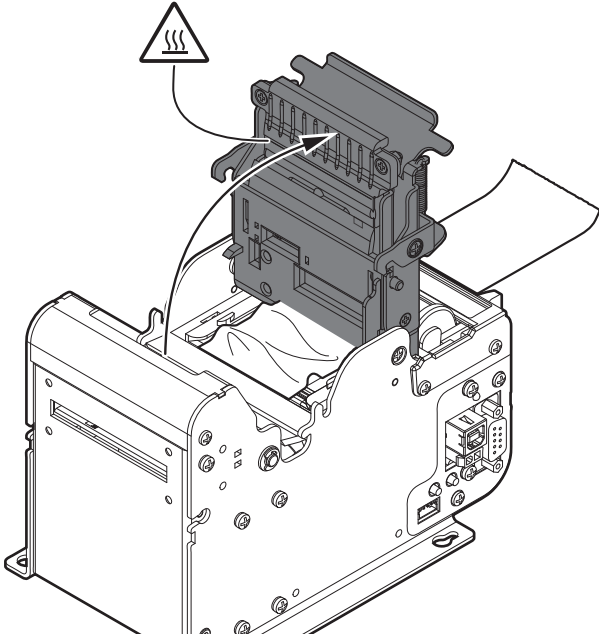

Open the upper cover of the device (see [paragraph 5.1](#)).

2

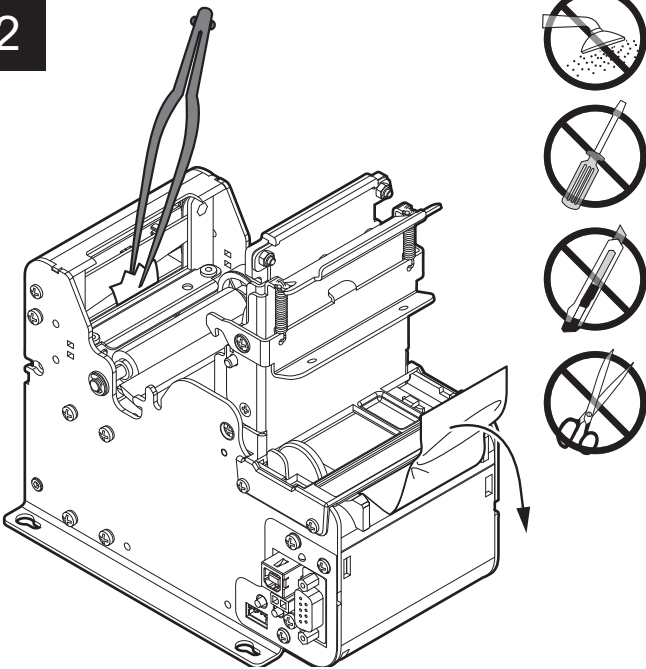

Remove the damaged paper and check the presence for paper scraps inside the device. Carefully remove all paper scraps. If necessary use tweezers.

3

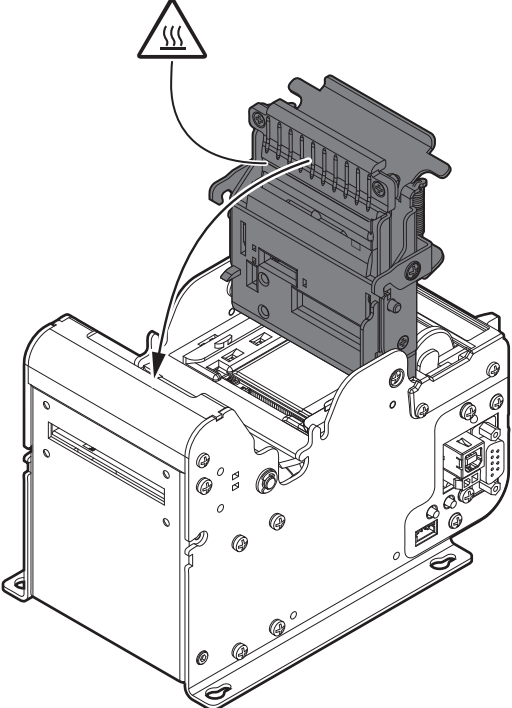

Close the upper cover of the device.

4

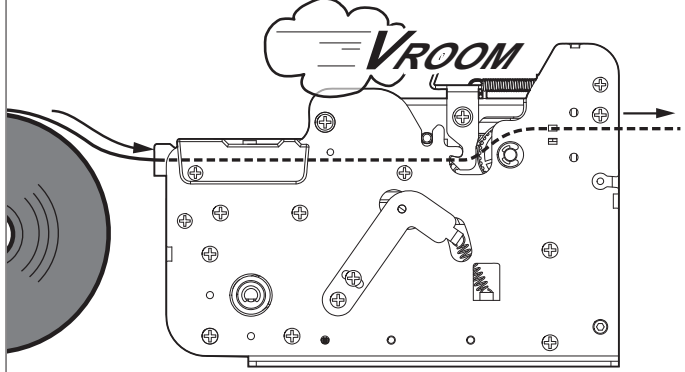



8.2 Planning of cleaning operations

The regular cleaning of the device keeps the print quality and extends its life. The following table shows the recommended planning for the cleaning operations.

If you use the device in dusty environments, you must reduce the intervals between the cleaning operations.

For ease of reference, in the following pages, for some models is represented only the printer group without the external plastic chassis.

EVERY PAPER CHANGE

Printing head	Use isopropyl alcohol
---------------	-----------------------

Printing roll	Use isopropyl alcohol
---------------	-----------------------

EVERY 5 PAPER CHANGES

Paper path	Use compressed air or tweezers
------------	--------------------------------

Sensors	Use compressed air
---------	--------------------

EVERY 6 MONTHS OR AS NEEDED

Case	Use compressed air or a soft cloth
------	------------------------------------

For specific procedures, see the following pages.

8.3 Cleaning

For periodic cleaning of the device, see the instructions below

Case

1

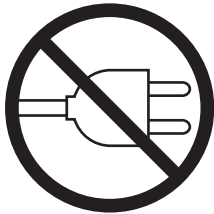

Disconnect the power supply cable.

2

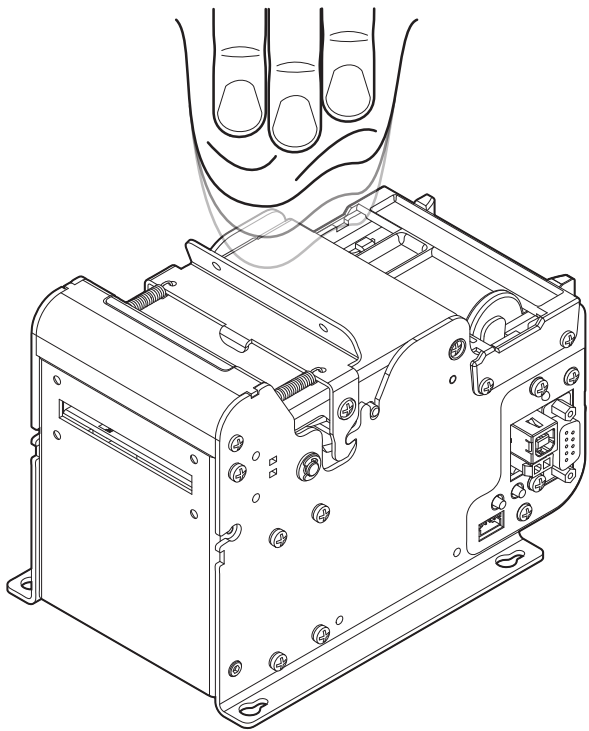

ATTENTION:
Do not use alcohol, solvents, or hard brushes.
Do not let water or other liquids get inside the machine.



To clean the device, use compressed air or a soft cloth.

Sensors

1

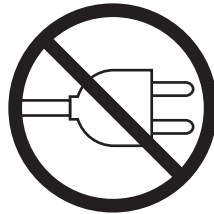

Disconnect the power supply cable and open the upper device cover (see [paragraph 5.1](#)).

2

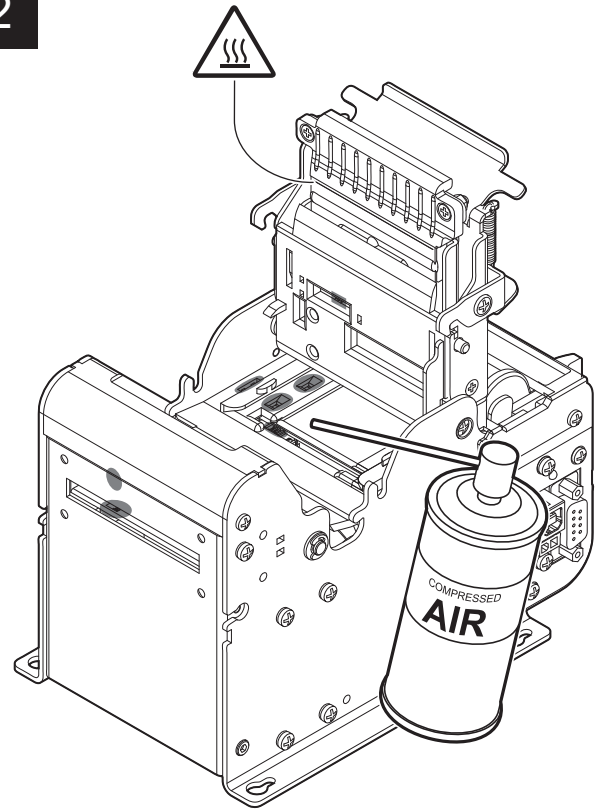

ATTENTION:
Do not use alcohol, solvents, or hard brushes.
Do not let water or other liquids get inside the machine.
To remove paper scraps, use tweezers or compressed air.



Clean all the device sensors by using compressed air.

Printhead

1

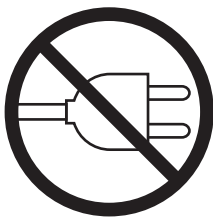

Disconnect the power supply cable and open the upper device cover (see [paragraph 5.1](#)).

2

ISOPROPYL ALCOHOL

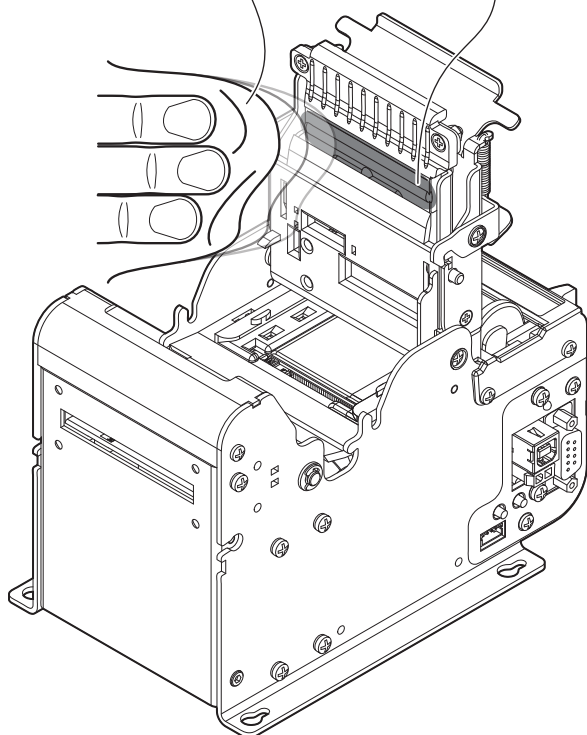

ATTENTION:

Do not use alcohol, solvents, or hard brushes.
Do not let water or other liquids get inside the machine.



Clean the printhead by using a non-abrasive cloth moistened with isopropyl.

Platen roller

1

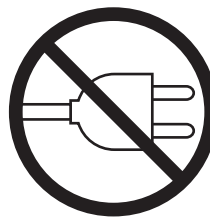

Disconnect the power supply cable and open the upper device cover (see [paragraph 5.1](#)).

2

ISOPROPYL ALCOHOL

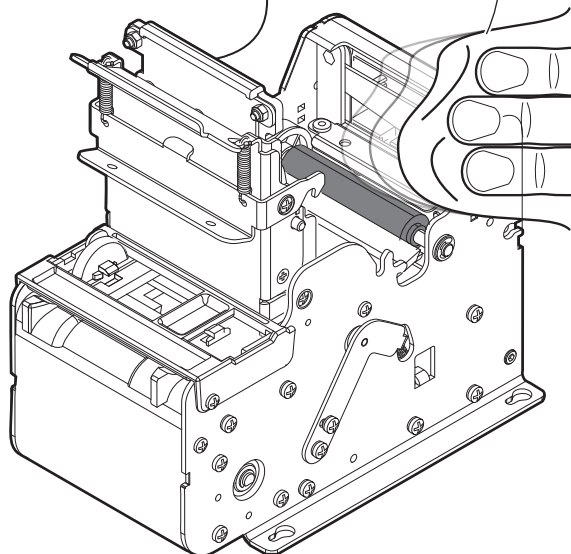

ATTENTION:

Do not use alcohol, solvents, or hard brushes.
Do not let water or other liquids get inside the machine.



Clean the platen roller by using a non-abrasive cloth moistened with isopropyl.

Paper path

1

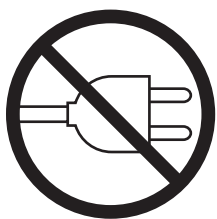

Disconnect the power supply cable and open the upper device cover (see [paragraph 5.1](#)).

2

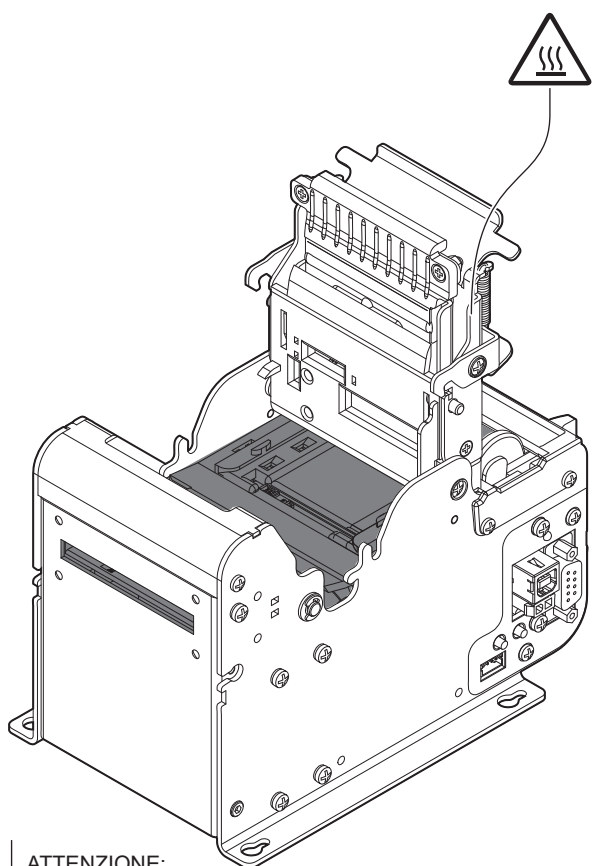

ATTENZIONE:
Non utilizzare solventi o spazzole dure. Assicurarsi che acqua o altri liquidi non penetrino all'interno del dispositivo.



Pulire la zona del dispositivo interessata dal passaggio della carta utilizzando aria compressa.

Cutter

1

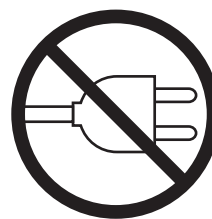

Disconnect the power supply cable and open the upper device cover (see [paragraph 5.1](#)).

2

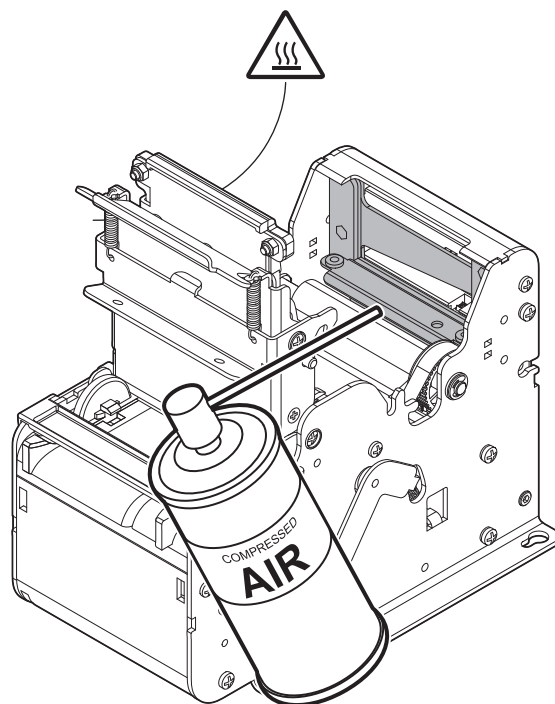

ATTENZIONE:
Non utilizzare solventi o spazzole dure. Assicurarsi che acqua o altri liquidi non penetrino all'interno del dispositivo.



Pulire la taglierina utilizzando aria compressa.

8.4 Upgrade firmware

Firmware upgrade can be performed by using the “PrinterSet” software tool available on www.custom4u.it. To upgrade firmware, proceed as follows:

1

www.CUSTOM4U.it

Login to the website www.custom4u.it, type in the product code of the device and download the latest firmware release available.

2

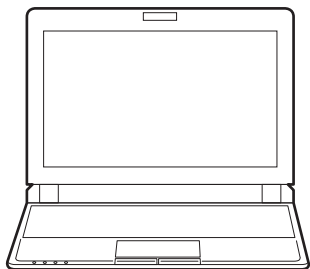

Connect the device to a PC directly (see [paragraph 4.3](#)), without using HUB devices.

3

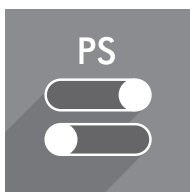

Avviare il tool “PrinterSet”.

4

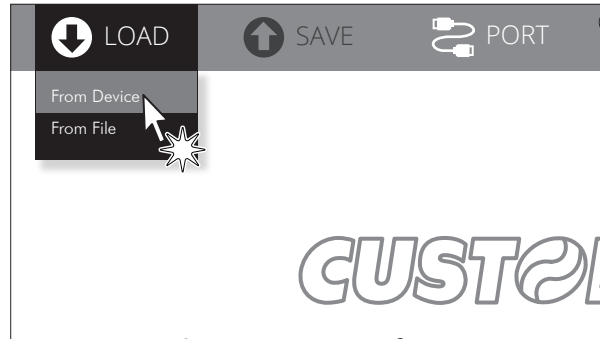

Cliccare su LOAD > FROM DEVICE e selezionare il dispositivo connesso al PC.

5

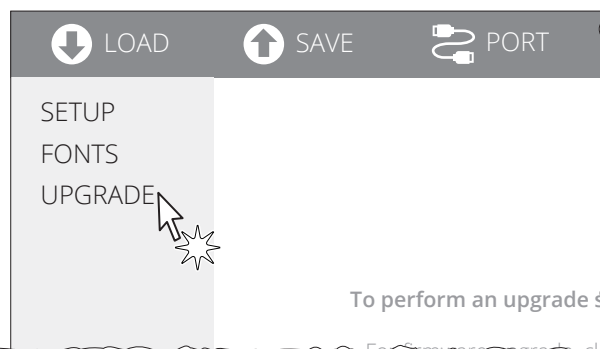

Cliccare su UPGRADE e seguire le istruzioni indicate a video.

ATTENTION:

During saving, it is strongly discouraged to disconnect the communication cable or to remove the power supply of the PC or the device.



9 SPECIFICATION

9.1 Hardware specifications

GENERAL	
Sensors	Head temperature, ticket presence, black mark detector in 3 positions, translucent gap/hole detector (setting by software), ticket presence on output, cover open, external low paper.
Noise	
B202HIII	66.3 dB
Emulations	CUSTOM/POS, SVELTA
Printing driver	Windows XP, VISTA (32/64bit), Windows 7 (32/64bit), Windows 8 (32/64 bit), Windows 8.1 (32/64 bit), Windows 10 (32/64 bit), Self-installing driver for Virtual COM (32/64 bit), Linux (32/64 bit), Android, iOS
INTERFACES	
USB port	12 Mbit/s
RS232 serial port	from 1200 bps to 115200 bps
MEMORIES	
Receive buffer	64 kB
Flash memory	18 MB
Graphic memory	Logos dynamic management (max 2 MB graphic memory)
Memory card SD/MMC ⁽¹⁾	Capacity = max 2 GB



PRINTER	
Resolution	203 dpi (8 dot/mm)
Printing method	Thermal, fixed head
Head life ⁽²⁾	
Abrasion resistance ⁽³⁾	150 Km (with recommended paper)
Pulse durability	100 M (12.5% duty cycle)
Print width	52 mm
Printing mode	Normal, 90°, 180°, 270°
Printing format	Height/Width from 1 to 8, bold, reverse, underlined, italic
Character font	
CUSTOM/POS emulation	54 character code tables (see paragraph 9.10), 2 TrueType fonts ⁽⁴⁾ Extended chinese GB18030-2000 ⁽⁵⁾ , Korean PC949, Traditional chinese BIG5 ⁽⁵⁾
SVELTA emulation	20 embedded fonts(see paragraph 9.11), 2 TrueType fonts ⁽⁴⁾
Printable barcode	UPCA, UPCE, EAN13, EAN8, CODE39, ITF, CODABAR, CODE93, CODE128, CODE32, PDF417, DATAMATRIX, AZTEC, QRCODE
Printing speed ^{(2) (6)}	
KPM150HIII,	High quality = 80 mm/s Normal = 120 mm/s High speed = 180 mm/s
B202HIII	High quality = 80 mm/s Normal = 117 mm/s High speed = 167 mm/s



PAPER

Type of paper	Thermal rolls, heat-sensitive side on outside of roll Thermal Fan-fold module with black mark alignment
Paper width	from 20 mm to 54 mm (2 mm step) 54mm (according to IATA BTP specifications - resolution 740)
Paper weight	from 80 g/m ² to 180 g/m ²
Recommended paper	KANZAN KPO 460 and KP415 MITSUBISHI TL1767 and TL4000
External roll diameter ⁽⁷⁾	max. Ø 200 mm
Internal roll core diameter	min 50 mm (+ 1 mm)
Core thickness	2 mm (+ 1 mm)
Paper end	Not attached to roll core
Core type	Cardboard or plastic
Minimum ticket length ⁽⁸⁾	27 mm

CUTTER

Paper cut	Total cut
Estimated life ⁽²⁾	1000000 uts

DEVICES ELECTRICAL SPECIFICATIONS

Power supply	24 Vdc ±10%
Medium consumption ⁽⁹⁾	
KPM150HIII	0.8 A
B202HIII	1.2 A
Typical consumption ⁽⁶⁾	0.9 A
Standby consumption	0.09 A



POWER SUPPLY ELECTRICAL SPECIFICATIONS code 963GE020000071 (Optional for KPM150HIII models)

Power supply voltage	from 100 Vac to 240 Vac
Frequency	from 50 Hz to 60 Hz
Output	24 V, 2.5 A
Power	60 W

ENVIRONMENTAL CONDITIONS

Operating temperature

KPM150HIII	from -10 to +60 °C
B202HIII	from 0°C to +50°C

Relative humidity from 10% Rh to 85% Rh (w/o condensation)

Storage temperature from -20 °C to +70 °C

Storage relative humidity from 10% Rh to 90% Rh (w/o condensation)

NOTES:

- (1) : Only for printer models equipped with SD/MMC.
- (2) : Respecting the regular schedule of cleaning for the device components.
- (3) : Damages caused by scratches, ESD and electromigration are excluded.
- (4) : "Veramono.ttf" and "Vera.ttf" are installed on device flash disk. It is possible to install additional TrueType fonts using the "PrinterSet" software tool (for further information about using this tool refer to the manual with code 78200000001800).
- (5) : For further information refer to the command manual for managing chinese fonts.
- (6) : Referred to a standard CUSTOM receipt (L=10 cm, Density = 12.5% dots on).
- (7) : For external rolls diameter higher to Ø 100 mm it's recommended to use a paper pretensioning device.
- (8) : Referred to models without cut/hold kit and ejecter/retention ticket. With these accessories installed is 75 mm.
- (9) : Referred to the UL measurements (max. normal load).



9.2 Character specifications

Character set		3	
Character density	11 cpi	15 cpi	20 cpi
Number of columns	35	45	64
Chars / sec	2900	3800	5300
Lines / sec	83	83	83
Characters (L x H mm)-Normal	2.25 x 3	1.75 x 3	1.25 x 3

Theoretical values.



9.3 Device dimensions

All the dimensions shown in the following figure are in millimeters and referred to devices with covers closed and without paper rolls.

KPM150HIII

Length	171 mm
Width	114 mm
Height	122 mm
Weight	1850 g

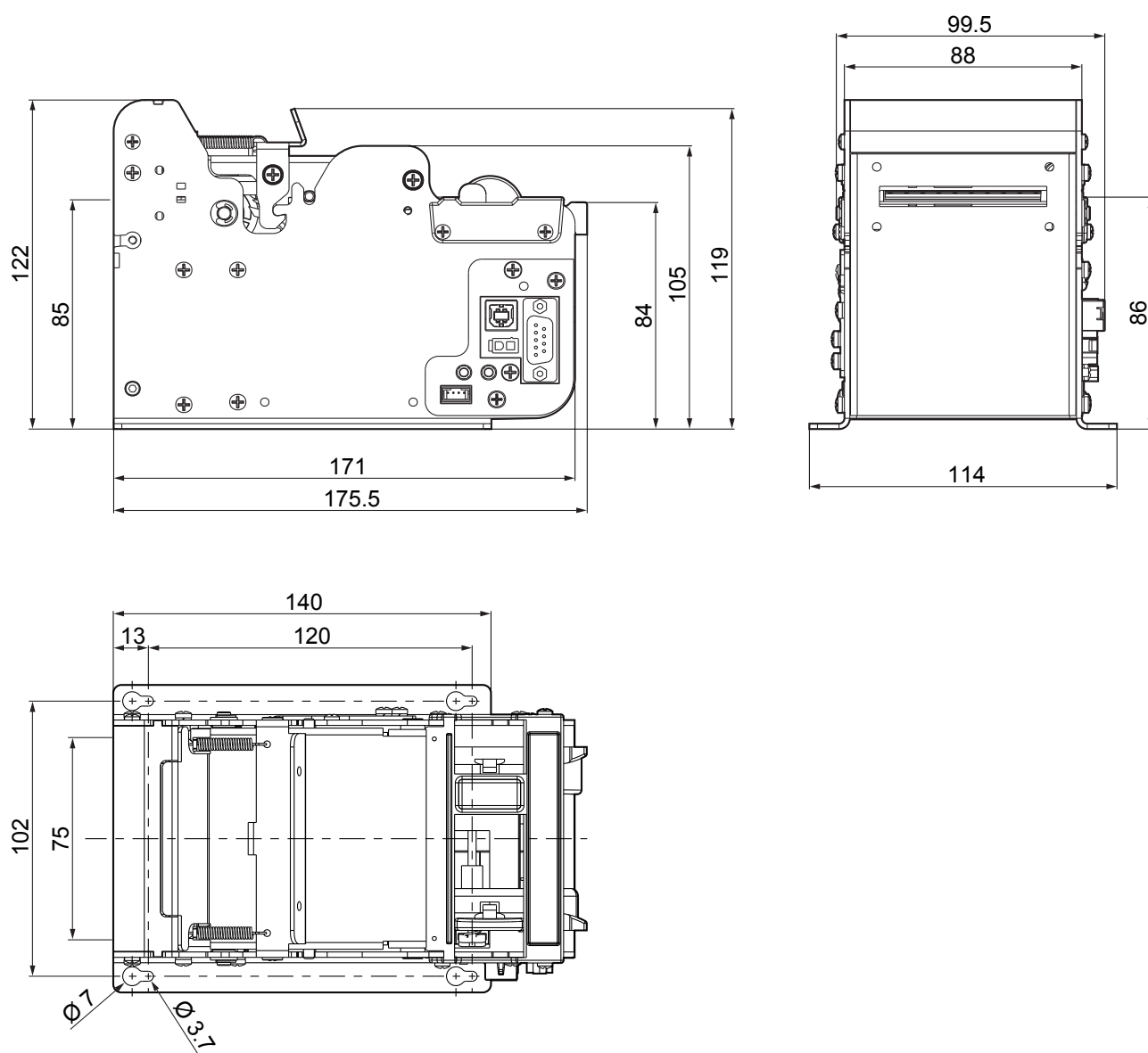



B202HIII.

Length	194 mm
Width	133 mm
Height	155 mm
Weight	2800 g

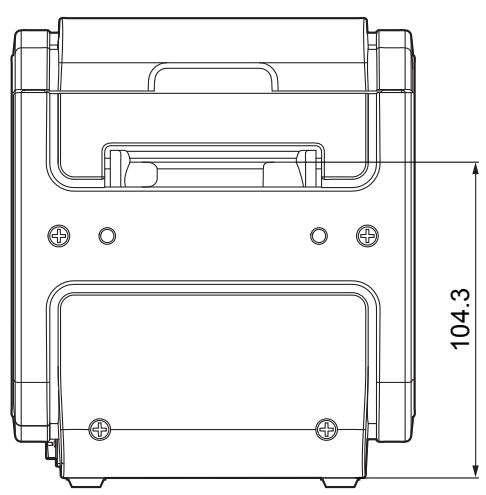
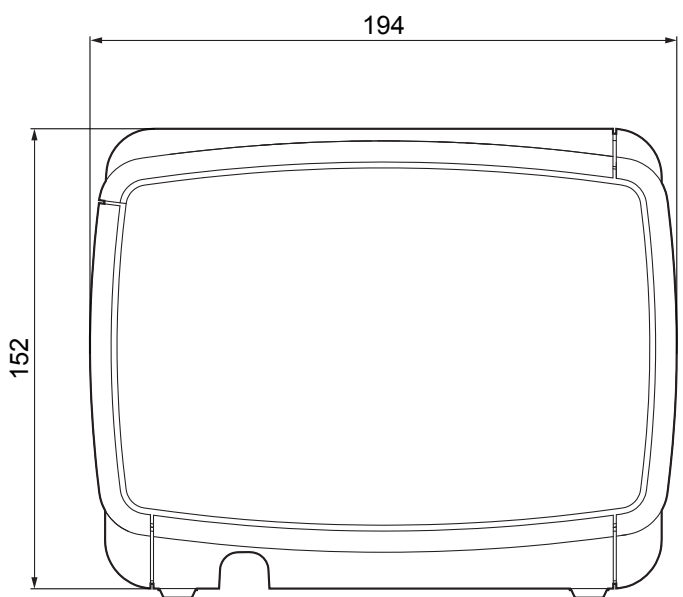
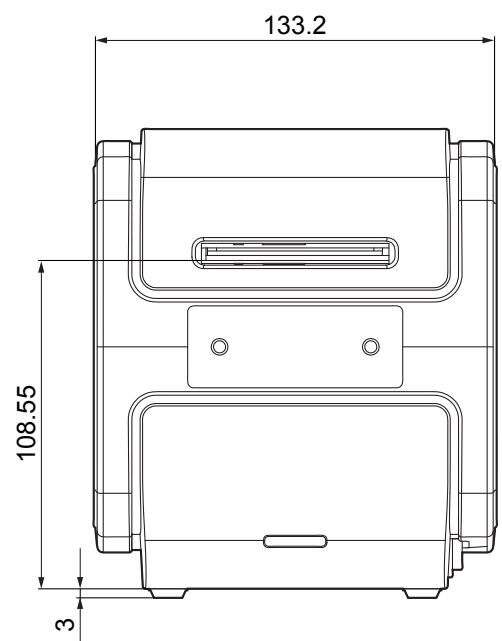



9.4 Device dimensions with cut/hold kit code 970AN01000001 (optional)

All the dimensions shown in figure are in millimeters and referred to devices with covers closed and without paper rolls.

KPM150HIII

Length	194 mm
Height	122 mm
Width	114 mm
Weight	1900 g

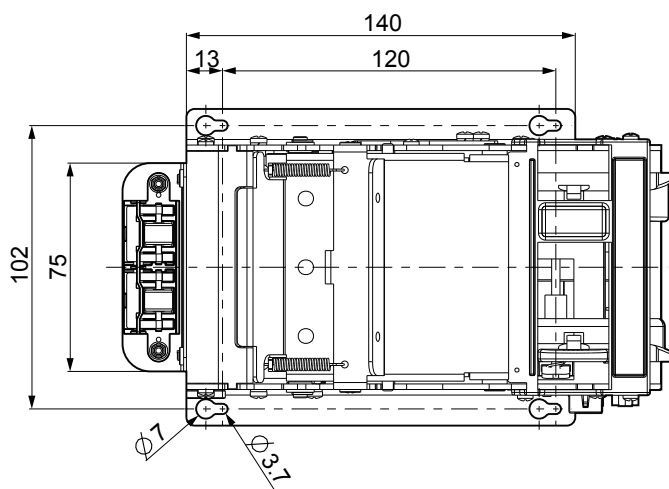
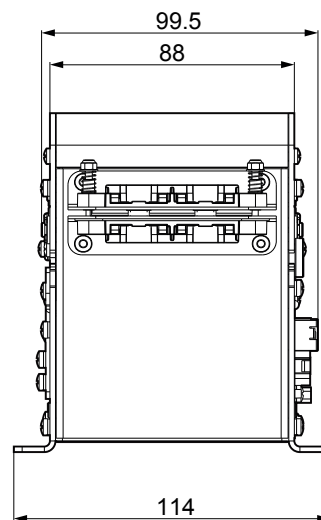
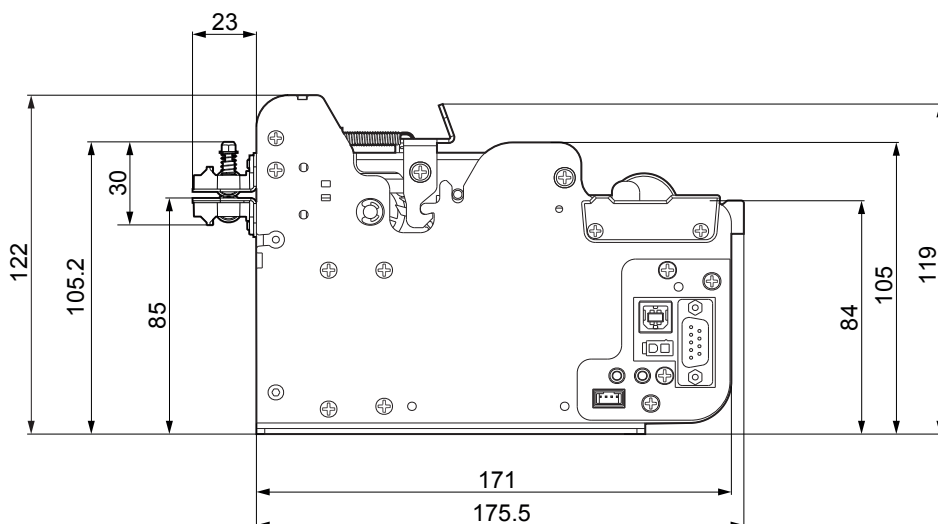



9.5 Device dimensions with ejecter / retention ticket plastic kit code 976FB03000001 (optional)

All the dimensions shown in figure are in millimeters and referred to devices with covers closed and without paper rolls.

KPM150HIII

Length	194 mm
Height	122 mm
Width	114 mm
Weight	1950 g

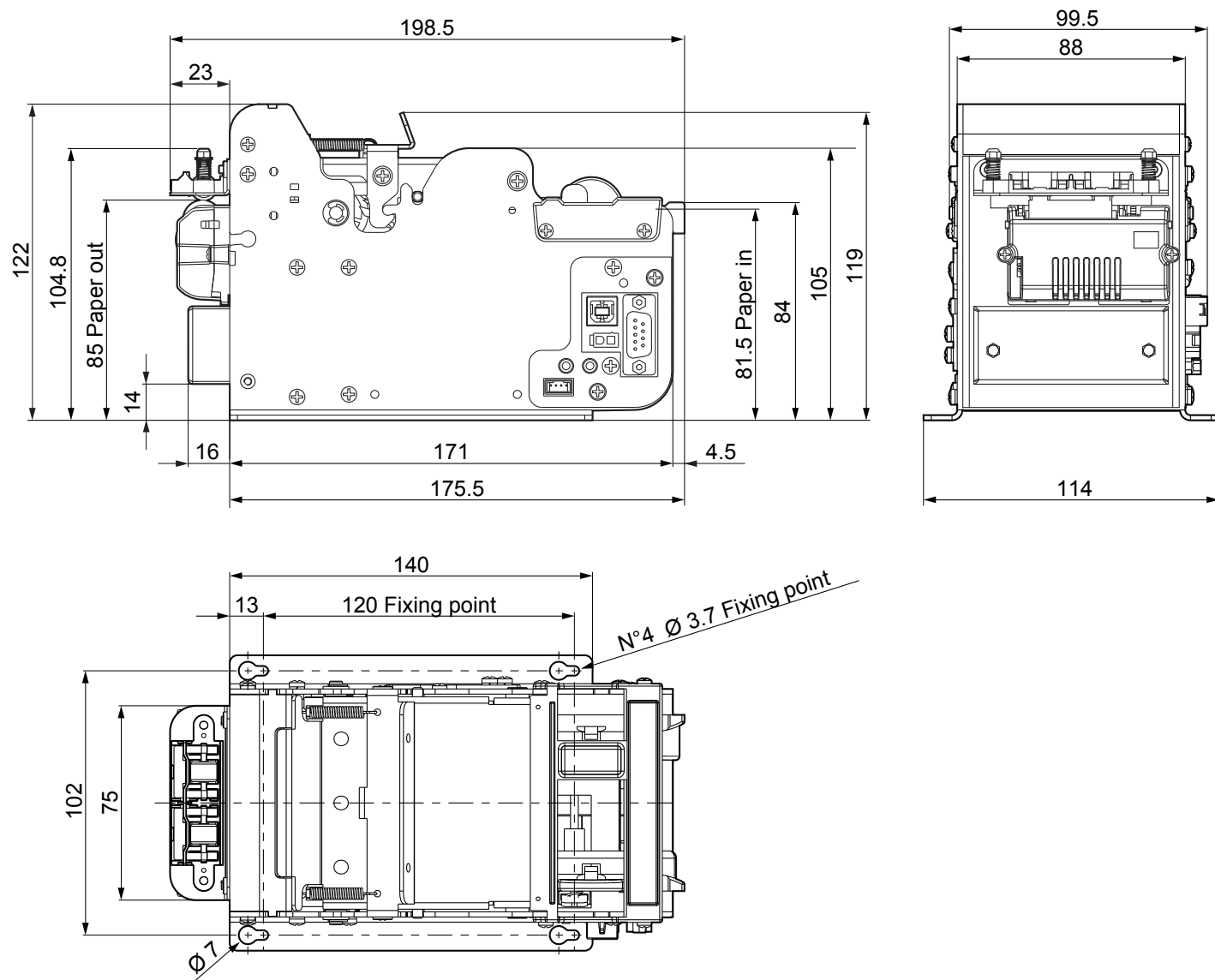



9.6 Device dimensions with paper roll holder code 974AP010000304 (optional)

All the dimensions shown in figure are in millimeters and referred to devices with covers closed and without paper rolls.

B202HIII

Length	364 mm
Height	155 mm
Width	133.2 mm
Weight	3800 g

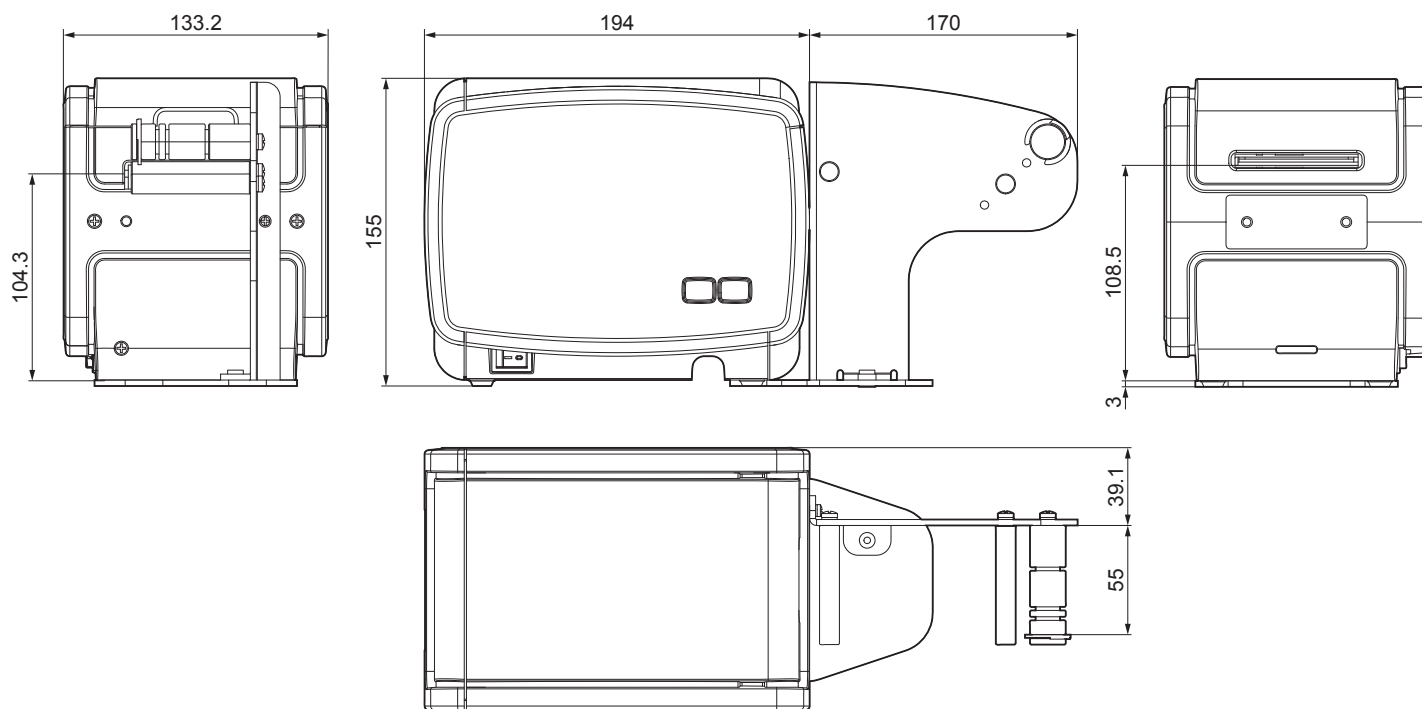



9.7 Device dimensions with metallic ticket tray code 9700000000200 (optional)

All the dimensions shown in figure are in millimeters and referred to devices with covers closed and without paper rolls.

B202HIII

Length	363.5 mm
Height	155 mm
Width	133.2 mm
Weight	3000 g

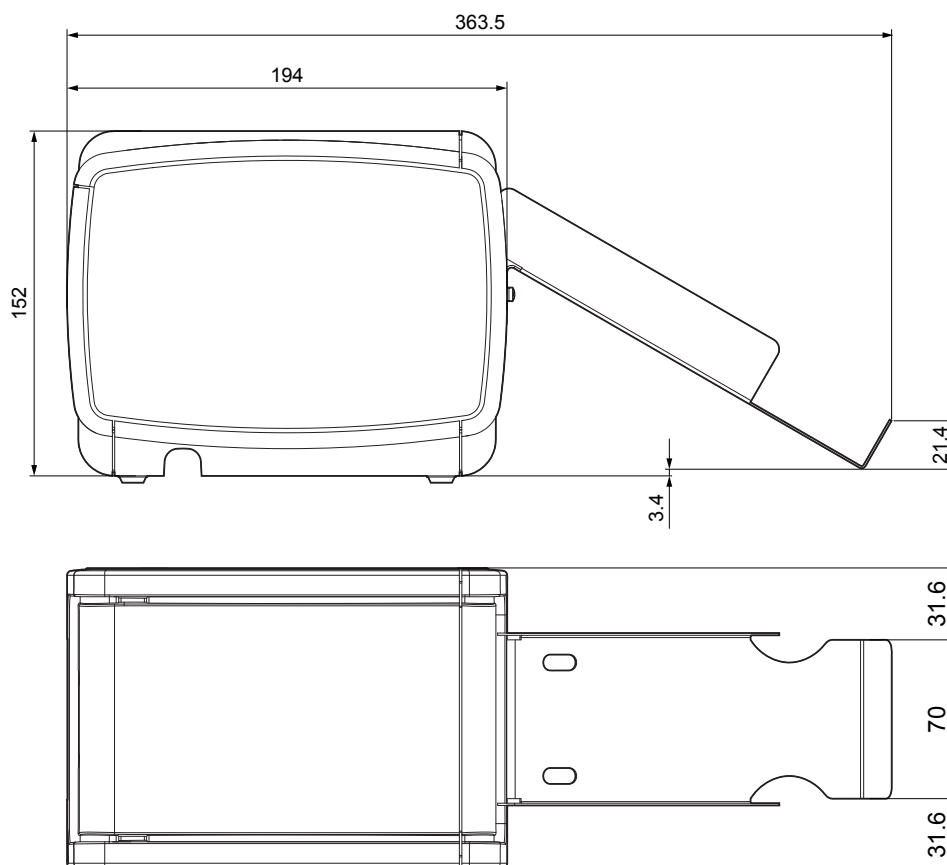



9.8 Dimensions of power supply, power cord and adapter cable (optionals)

The following table shows the dimensions of the power supply, the power cord and the adapter cable available for the device:

POWER SUPPLY code 963GE020000071	
Length	127 mm
Height	35.5 mm
Width	56 mm
POWER CORD code 26100000000311 (only for B202HIII)	
Length	2000 mm
ADAPTER CABLE code 26900000000005 (only for KPM150HIII, models)	
Length	200 mm

Power supply code 963GE020000071

All the dimensions shown in figures are in millimeters.

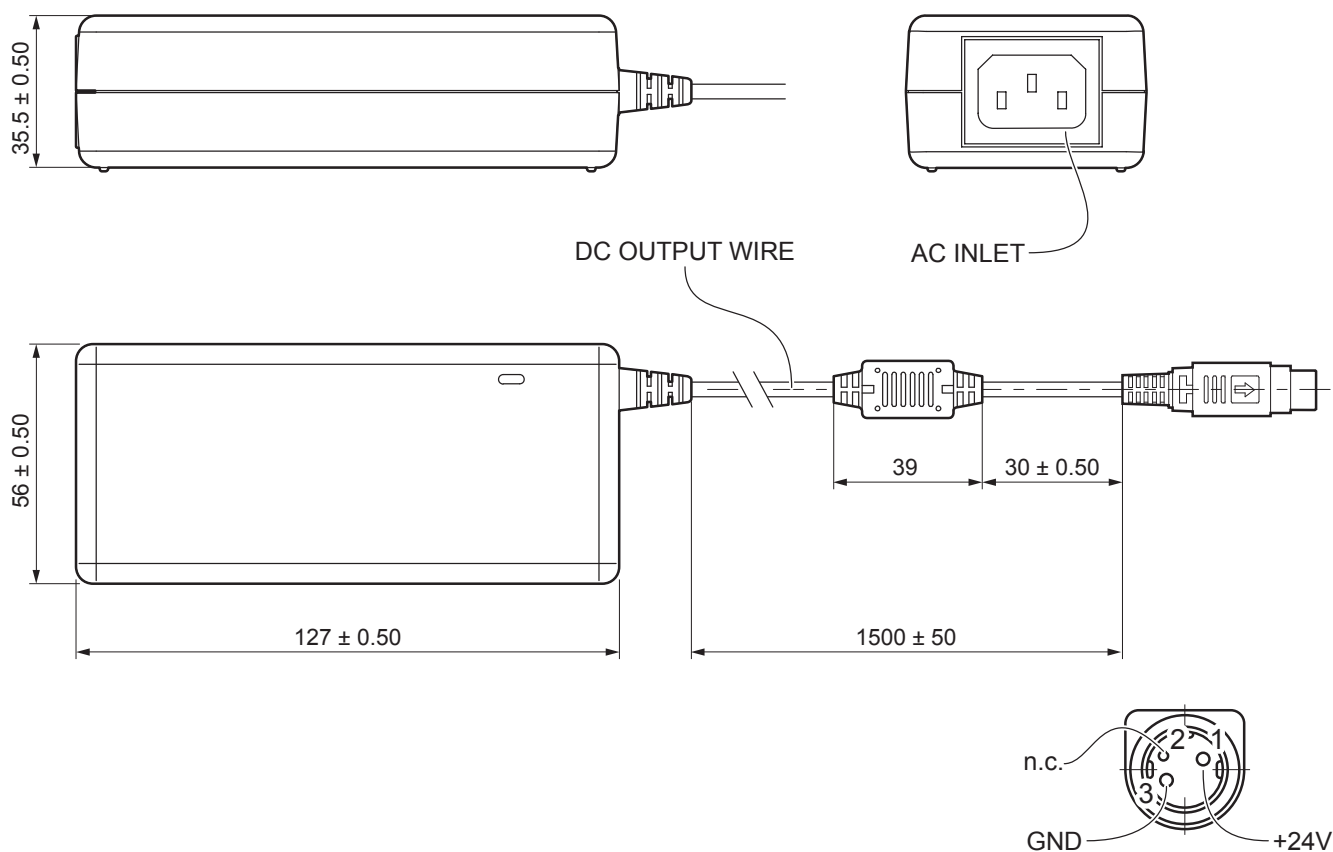



Power cord code 26100000000311

All the dimensions shown in figures are in millimeters.

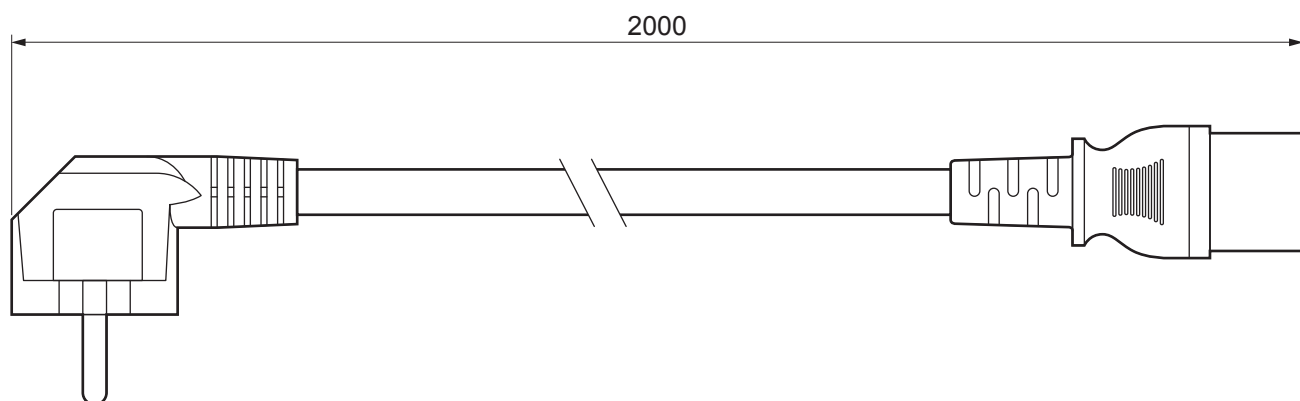

Adapter cable code 26900000000005

All the dimensions shown in figures are in millimeters.

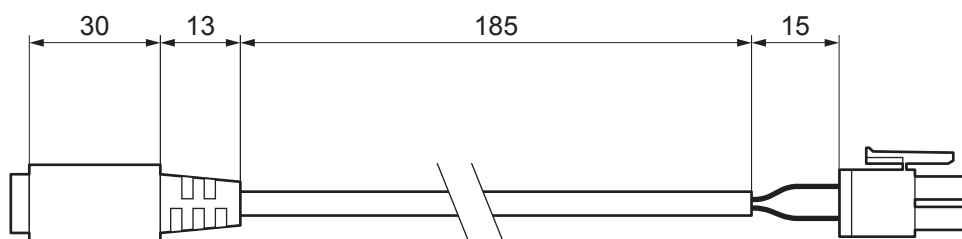

9.9 Paper specification

Paper with black mark on the non-thermal side

The following image shows the placement of the black mark on the non-thermal side of the paper. The black mark can be positioned anywhere on the whole width of the paper, because the black mark detector is a mobile sensor. For more information about the use of paper with black mark see [chapter 7](#).

All the dimensions shown in figures are in millimeters.

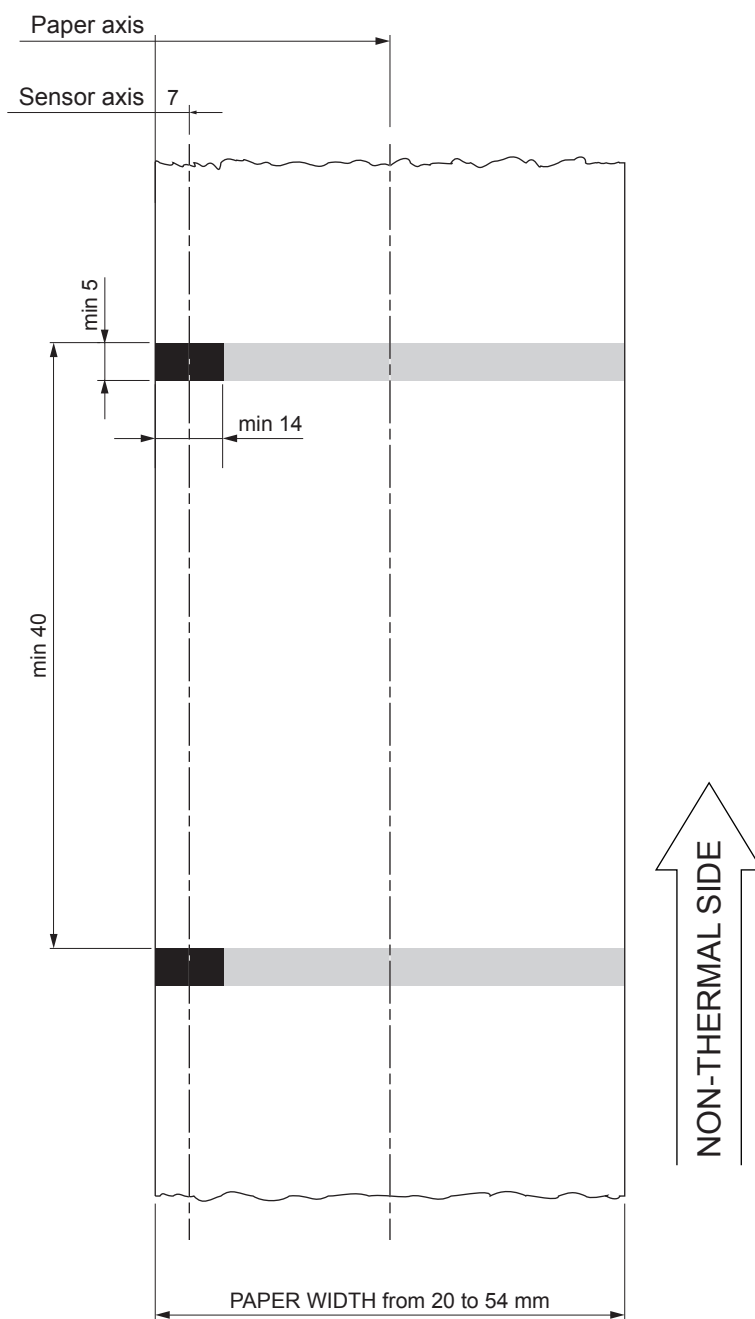

Paper with black mark on the thermal side

The following image shows the placement of the black mark on the thermal side of the paper. This sample paper is for the printer models with the upper black mark detector. For more information about the use of paper with black mark see [chapter 7](#).

All the dimensions shown in figures are in millimeters.

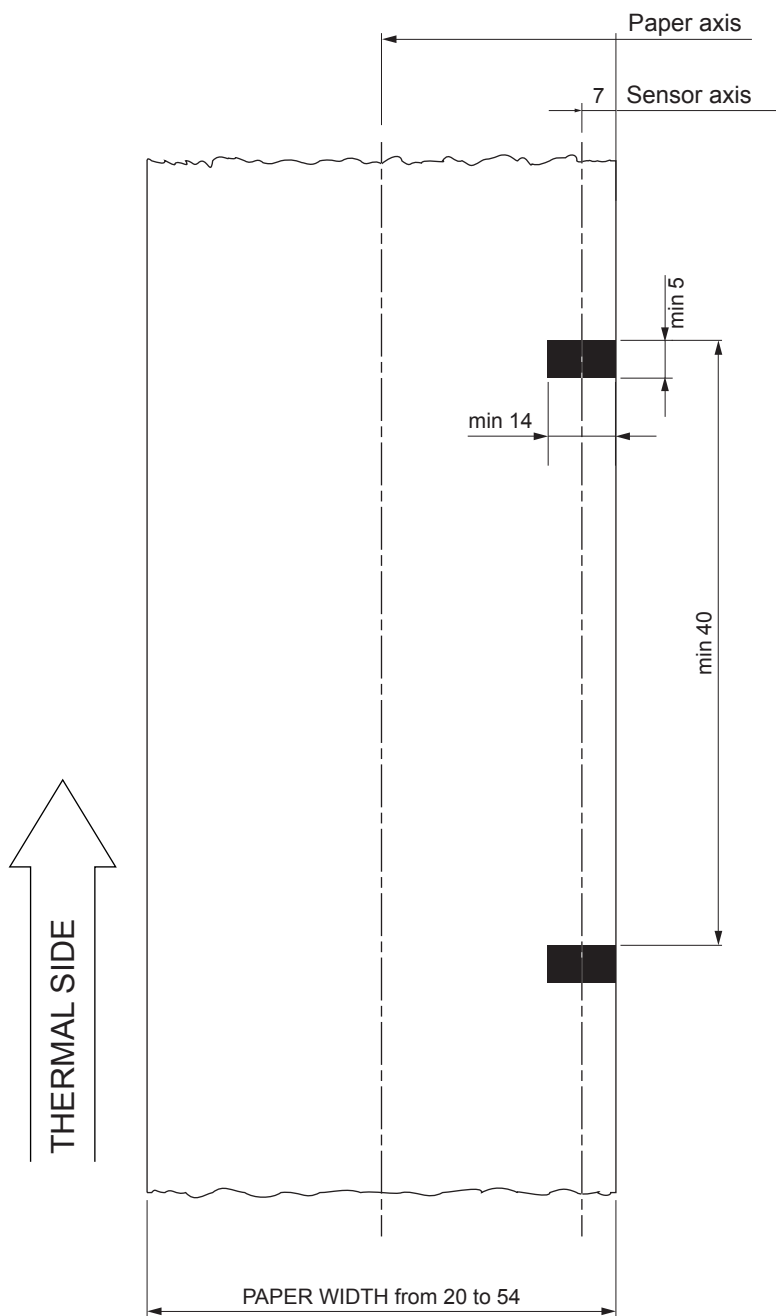

Paper with labels

The following image shows a portion of paper with labels. To manage paper with label, you need to set the parameter "Ticket Management" to "Short Label" value (see [chapter 6](#)). For more information about the use of paper with labels see [chapter 7](#).

All the dimensions shown in figures are in millimeters.

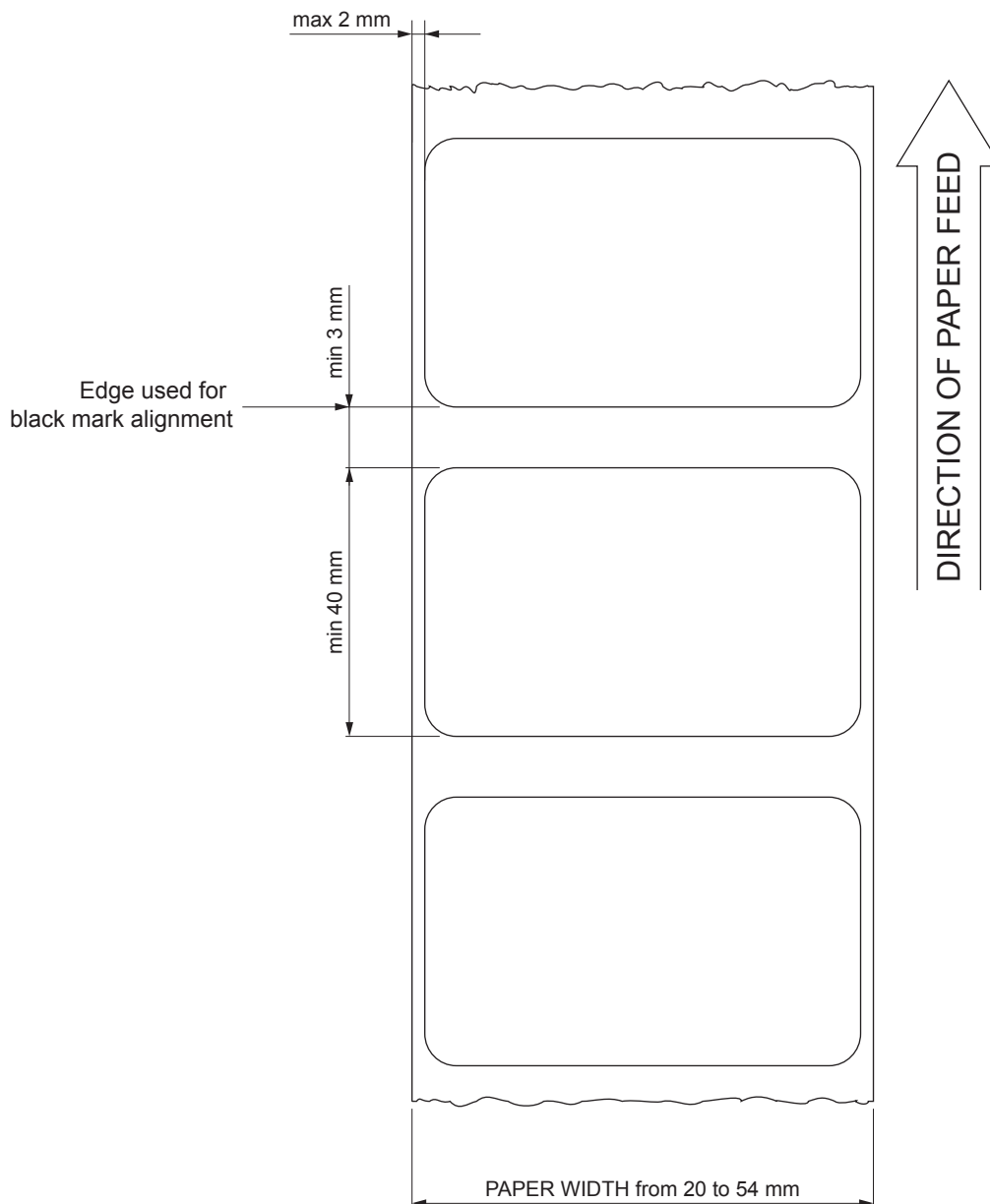

Fan-fold paper with hole

The following image shows the placement of the hole on the paper. To manage tickets with hole, set the parameter “Black Mark Position” to “Transparent” (see [chapter 6](#)). For more information about the use of paper with hole see [chapter 7](#).

The valid format of the ticket is ISO size 54 x 85mm.

All the dimensions shown in figures are in millimeters.

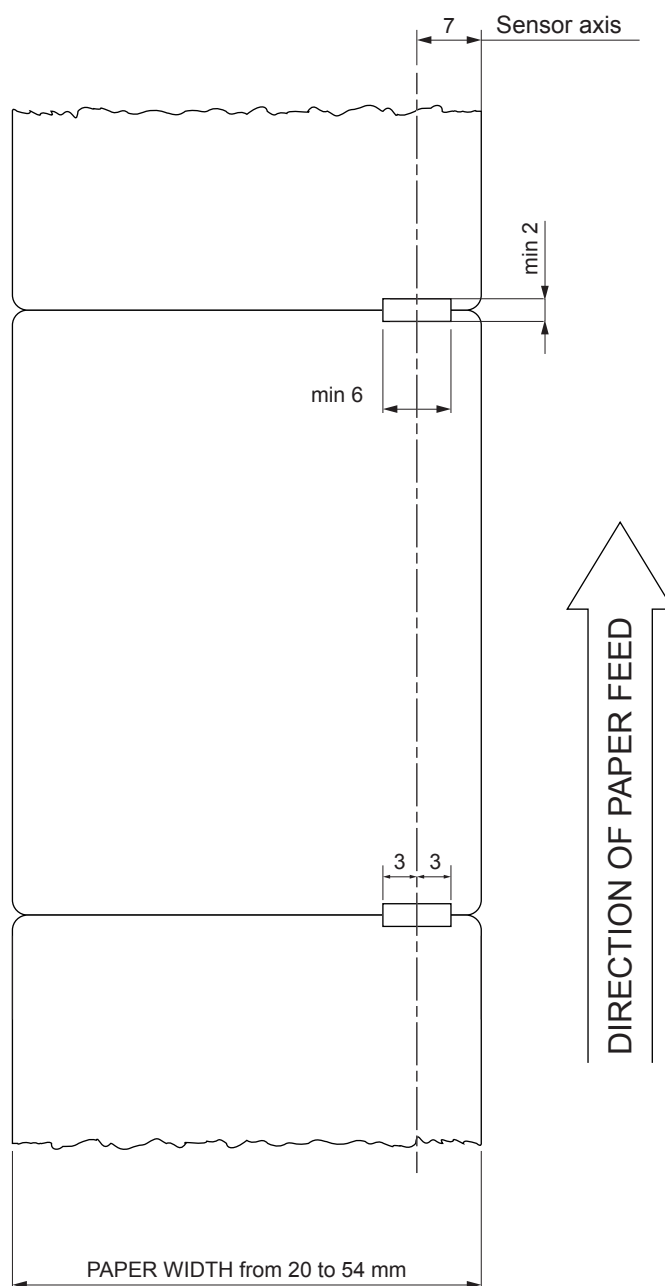



9.10 Character sets in CUSTOM/POS emulation

The device has 4 fonts of varying width (11, 15, 20 and 25 cpi) which may be related one of the coding tables provided on the device.

To know the coding tables actually present on the device, you need to print the font test (see [paragraph 3.6](#)).

You can set font and coding table by using the commands (see the Commands Manual of the device) or using the “Code Table” and the “Chars / Inch” parameters during the setup procedure (see [paragraph 6.7](#)).

The following is the full list of coding tables that can be installed on the device.

<CodeTable>	Coding table	
0	PC437 - U.S.A., Standard Europe	
1	Katakana	
2	PC850 - Multilingual	
3	PC860 - Portuguese	
4	PC863 - Canadian/French	
5	PC865 - Nordic	
11	PC851 - Greek	on request
12	PC853 - Turkish	on request
13	PC857 - Turkish	
14	PC737 - Greek	
15	ISO8859-7 - Greek	on request
16	WPC1252	
17	PC866 - Cyrillic 2	
18	PC852 - Latin 2	
19	PC858 for Euro symbol in position 213	
20	KU42 - Thai	
21	TIS11 - Thai	on request
26	TIS18 - Thai	on request
30	TCVN_3 - Vietnamese	on request
31	TCVN_3 - Vietnamese	on request
32	PC720 - Arabic	on request
33	WPC775 - Baltic Rim	on request



<CodeTable>	Coding table
34	PC855 - Cyrillic
35	PC861 - Icelandic on request
36	PC862 - Hebrew
37	PC864 - Arabic
38	PC869 - Greek on request
39	ISO8859-2 - Latin 2 on request
40	ISO8859-15 - Latin 9 on request
41	PC1098 - Farci
42	PC1118 - Lithuanian on request
43	PC1119 - Lithuanian on request
44	PC1125 - Ukrainian
45	WPC1250 - Latin 2
46	WPC1251 - Cyrillic
47	WPC1253 - Greek
48	WPC1254 - Turkish
49	WPC1255 - Hebrew
50	WPC1256 - Arabic
51	WPC1257 - Baltic Rim
52	WPC1258 - Vietnamese
53	KZ1048 - Kazakhstan on request
255	Space page

In CUSTOM/POS emulation, it is possible to use TrueType fonts. To be used, a TrueType font must be monospace type (every character of the font must have the same dimension). The check is made by the device when the font is selected.

TrueType fonts will be automatically scaled by the device in order to obtain the same available width for the embedded fonts (11, 15, 20 and 25 cpi).

The quality of TrueType fonts, the correct positioning into the printable area and the available code tables, will result from the font producers and the font implementation.

For the correct printing of the code tables, it is necessary that the selected TrueType font contains all the characters in the tables. Otherwise, the '□' symbol will be printed instead the missing character. All commands for printing configuration are usable both with TrueType fonts and with embedded fonts. It is possible to address the TrueType font respects the UNICODE standard (see www.unicode.org), by using UTF-8 or UTF-16 encoding.



9.11 Character sets in SVELTA emulation

In SVELTA emulation, the device has 20 embedded fonts of varying width which may be accessed through control characters (see the Commands Manual of the device). The following list shows the font available and relative dimensions in dot:

- Font HEL8PT8 ^(A) Proportional Font with fixed height (H = 28 dot)
- Font HEL10PT8 ^(A) Proportional Font with fixed height (H = 34 dot)
- Font HEL14PT8 ^(A) Proportional Font with fixed height (H = 50 dot)
- Font HEL16PT8 ^(A) Proportional Font with fixed height (H = 55 dot)
- Font 18x24 (Font 18x24 in CUSTOM/POS emulation)
- Font 14x24 (Font 14x24 in CUSTOM/POS emulation)
- Font 10x24 (Font 10x24 in CUSTOM/POS emulation)
- Font 8x12 ^(B) Fixed Font
- Font 8x12-2 ^(B) Fixed Font
- Font 12x12 ^(B) Fixed Font
- Font 14x11 ^(B) Fixed Font
- Font 16x24 ^(B) Fixed Font
- Font 16x24_1 ^{(B) (C)} Fixed Font
- Font 16x24_2 ^{(B) (C)} Fixed Font
- Font 20x15 ^(B) Fixed Font
- Font 28x20 ^(B) Fixed Font
- Font 14x24_1 ^{(B) (C)} Fixed Font
- Font 16x24CN ^{(B) (C)} Fixed Font
- Font OCRB (20x32) ^(B) Fixed Font

For further information to characters representations print the Font Test ^(D).

NOTES:

- ^(A) A proportional font is a font in which different characters have different pitches (widths).
- ^(B) A fixed font is the opposite of a proportional font and is a fixed-pitch font.
- ^(C) The fonts with the same name and dimension contain different characters in different positions from theirs.
- ^(D) During power-up, if the FF FORM FEED key is held down, the device executes the FONT TEST.

In SVELTA emulation, it is possible to use TrueType fonts. True Type fonts are printable with every angle of rotation and in bold, reverse, italic and underlined mode.

It is possible to address the TrueType font respects the UNICODE standard (see www.unicode.org), by using UTF-8 or UTF-16 encoding.

For the correct printing of the code tables, it is necessary that the selected TrueType font contains all the characters in the tables. Otherwise, the '□' symbol will be printed instead the missing character.



10 CONSUMABLES

The following table shows the list of available consumables for device:

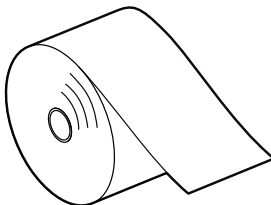
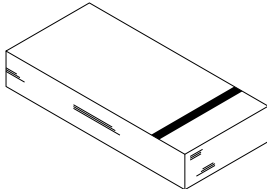

DESCRIPTION	CODE
<p>THERMAL PAPER ROLL</p> <p>weight = 74 g/m² width = 54 mm Ø external = 90 mm Ø core = 50 mm</p>	<p>67300000000342</p> 
<p>THERMAL FANFOLD MODULE (100 tickets)</p> <p>weight = 140 g/m² dimensions = 86 mm x 54 mm</p>	<p>67600000000301</p> 



11 ACCESSORIES

The following table shows the list of available accessories for device.

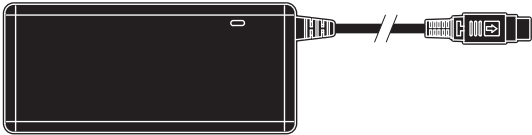
KPM150HIII,

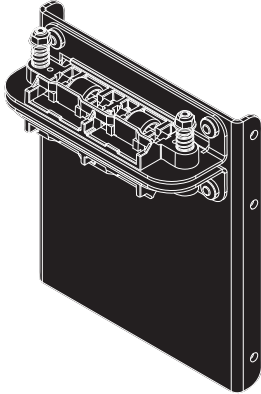
DESCRIPTION	CODE
<p>POWER SUPPLY (for technical specifications, see paragraph 9.1)</p>	<p>963GE02000071</p> 
<p>POWER CORD SCHUKO PLUG length = 2 m (see paragraph 9.8)</p>	<p>2610000000311</p> 
<p>ADAPTER CABLE FOR POWER SUPPLY length = 200 mm (see paragraph 9.8)</p>	<p>2690000000005</p> 
<p>CUT/HOLD KIT (for technical specifications, see paragraph 9.4)</p>	<p>970AN01000001</p> 



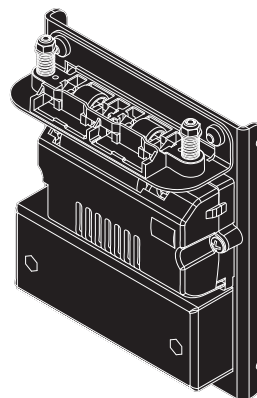

976FB03000001

PLASTIC EJECTER / RETENTION TICKET KIT
(for technical specifications, see [paragraph 9.5](#))



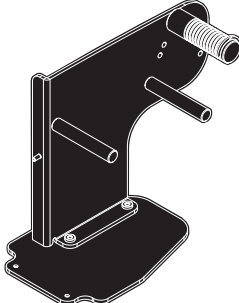

B202HIII

DESCRIPTION	CODE
<p>PAPER ROLL HOLDER (for technical specifications, see paragraph 9.6)</p>	<p>974AP010000304</p> 
<p>ADDITIONAL CABLE FOR LOW PAPER SENSOR cable 400 mm long</p>	<p>26300000000519</p> 
<p>ADDITIONAL LOW PAPER SENSOR BOARD</p>	<p>81300000000383</p> 

11.1 Adapter cable for power supply

For the device is available an adapter cable (code 26900000000005) supplied as an accessory, for connecting the device to the external power supply unit (code 963GE020000071- optional).

KPM150HIII

Assembly instructions

Connect the adapter cable to the power supply unit as follows:

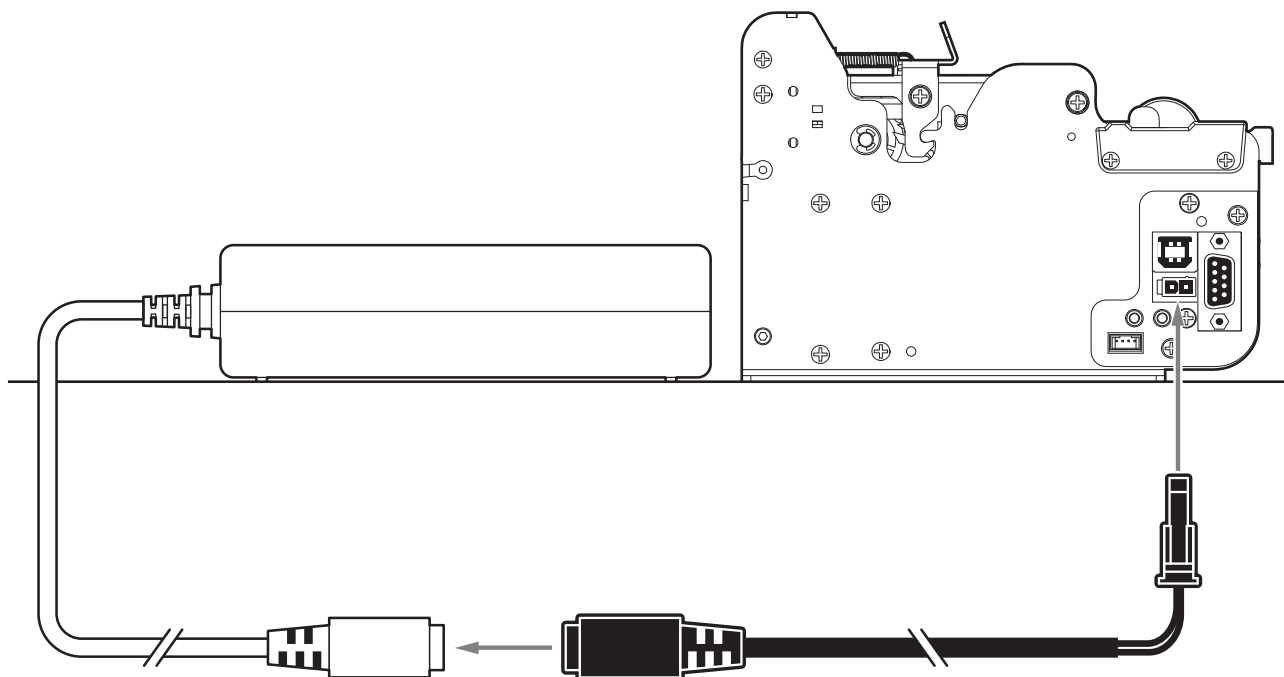



12 TECHNICAL SERVICE

In case of failure, contact the technical service accessing the website www.custom4u.it and using the support tools on the homepage. It is advisable to keep the identification data of the product at hand.

The product code, the serial number and the hardware release number can be found on the product label (see [paragraph 3.5](#)).

The firmware release number (SCODE) can be found:

- on the setup report (see [paragraph 6.1](#));
- connecting the device to a PC and starting the "PrinterSet" tool (see [paragraph 6.2](#));
- by consulting the "setup.ini" file (see [paragraph 6.3](#)).



CUSTOM[®]

CUSTOM S.p.A.

World Headquarters

Via Berettine, 2/B - 43010 Fontevivo, Parma ITALY

Tel. +39 0521 680111 - Fax +39 0521 610701

info@custom.biz - www.custom.biz

All rights reserved