

USER MANUAL

---

**KPM180H**

**TK180**

**CUSTOM<sup>®</sup>**



CUSTOM S.p.A.  
Via Berettine 2/B  
43010 Fontevivo (PARMA) - Italy  
Tel. : +39 0521-680111  
Fax : +39 0521-610701  
http: www.custom.biz

Customer Service Department:  
www.custom4u.it

© 2023 CUSTOM S.p.A. – Italy.  
All rights reserved. Total or partial reproduction of this manual in whatever form, whether by printed or electronic means, is forbidden. While guaranteeing that the information contained in it has been carefully checked, CUSTOM S.p.A. and other entities utilized in the realization of this manual bear no responsibility for how the manual is used. Information regarding any errors found in it or suggestions on how it could be improved are appreciated. Since products are subject to continuous check and improvement, CUSTOM S.p.A. reserves the right to make changes in information contained in this manual without prior notification.

The pre-installed multimedia contents are protected from Copyright CUSTOM S.p.A. Other company and product names mentioned herein may be trademarks of their respective companies. Mention of third-party products is for informational purposes only and constitutes neither an endorsement nor a recommendation. CUSTOM S.p.A. assumes no responsibility with regard to the performance or use of these products.

**THE IMAGES USED IN THIS MANUAL ARE USED AS AN ILLUSTRATIVE EXAMPLES. THEY COULDN'T REPRODUCE THE DESCRIBED MODEL FAITHFULLY.**

**UNLESS OTHERWISE SPECIFIED, THE INFORMATION GIVEN IN THIS MANUAL ARE REFERRED TO ALL MODELS IN PRODUCTION AT THE ISSUE DATE OF THIS DOCUMENT.**

#### GENERAL INSTRUCTIONS

CUSTOM S.p.A. declines all responsibility for accidents or damage to persons or property occurring as a result of tampering, structural or functional modifications, unsuitable or incorrect installations, environments not in keeping with the equipment's protection degree or with the required temperature and humidity conditions, failure to carry out maintenance and periodical inspections and poor repair work.

#### GENERAL SAFETY INFORMATION

Your attention is drawn to the following actions that could compromise the characteristics of the product:

- Read and retain the instructions which follow.
- Follow all indications and instructions given on the device.
- Make sure that the surface on which the device rests is stable. If it is not, the device could fall, seriously damaging it.
- Make sure that the device rests on a hard (non-padded) surface and that there is sufficient ventilation.
- Do not fix indissolubly the device or its accessories such as power supplies unless specifically provided in this manual.
- When positioning the device, make sure cables do not get damaged.
- [Only OEM equipment] The equipment must be installed in a kiosk or system that provides mechanical, electrical and fire protection.
- The mains power supply must comply with the rules in force in the Country where you intend to install the equipment.
- Make sure that there is an easily-accessible outlet with a capacity of no less than 10A closely to where the device is to be installed.
- Make sure the power cable provided with the appliance, or that you intend to use is suitable with the wall socket available in the system.
- Make sure the electrical system that supplies power to the device is equipped with a ground wire and is protected by a differential switch.
- Before any type of work is done on the machine, disconnect the power supply.
- Use the type of electrical power supply indicated on the device label.
- These devices are intended to be powered by a separately certified power module having an SELV, non-energy hazardous output. (IEC60950-1 second edition).
- [Only POS equipment] The energy to the equipment must be provided by power supply approved by CUSTOM S.p.A.
- Take care the operating temperature range of equipment and its ancillary components.
- Do not block the ventilation openings.
- Do not insert objects inside the device as this could cause short-circuiting or damage components that could jeopardize printer functioning.
- Do not carry out repairs on the device yourself, except for the normal maintenance operations given in the user manual.
- The equipment must be accessible on these components only to trained, authorized personnel.
- Periodically perform scheduled maintenance on the device to avoid dirt build-up that could compromise the correct, safe operation of the unit.
- Do not touch the head heating line with bare hands or metal objects. Do not perform any operation inside the printer immediately after printing because the head and motor tend to become very hot.
- Use consumables approved by CUSTOM S.p.A.



THE CE MARK AFFIXED TO THE PRODUCT CERTIFY THAT THE PRODUCT SATISFIES THE BASIC SAFETY REQUIREMENTS.

The device is in conformity with the essential Electromagnetic Compatibility and Electric Safety requirements laid down in Directives 2014/30/EU and 2014/35/EU inasmuch as it was designed in conformity with the provisions laid down in the following Standards:

- EN 55032 (*Electromagnetic compatibility of multimedia equipment - Emission Requirements*)
- EN 55024/EN55035 (*Electromagnetic compatibility of multimedia equipment - Immunity requirements*)
- EN IEC/EN62368-1 (*Audio/video, information and communication technology equipment*)

The device is in conformity with the essential requirements laid down in Directives 2014/53/EU about devices equipped with intentional radiators. The Declaration of Conformity and other available certifications can be downloaded from the site [www.custom4u.it](http://www.custom4u.it).



GUIDELINES FOR THE DISPOSAL OF THE PRODUCT

The crossed-out rubbish bin logo means that used electrical and electronic products shall NOT be mixed with unsorted municipal waste. For more detailed information about recycling of this product, refer to the instructions of your country for the disposal of these products.

- Do not dispose of this equipment as miscellaneous solid municipal waste, but arrange to have it collected separately.
- The re-use or correct recycling of the electronic and electrical equipment (EEE) is important in order to protect the environment and the wellbeing of humans.
- In accordance with European Directive WEEE 2012/19/EU, special collection points are available to which to deliver waste electrical and electronic equipment and the equipment can also be handed over to a distributor at the moment of purchasing a new equivalent type.
- The public administration and producers of electrical and electronic equipment are involved in facilitating the processes of the re-use and recovery of waste electrical and electronic equipment through the organisation of collection activities and the use of appropriate planning arrangements.
- Unauthorised disposal of waste electrical and electronic equipment is punishable by law with the appropriate penalties.



The format used for this manual improves use of natural resources reducing the quantity of necessary paper to print this copy.



FCC STATEMENT  
(FEDERAL COMMUNICATIONS  
COMMISSIONS).

This note is valid only for device bringing FCC  
trademark.

This device complies with Part 15 of the FCC  
Rules. Operation is subject to the following  
conditions:

The devices may not cause harmful interference.  
The devices must accept any interference  
received, including interference that may cause  
undesired operation.

NOTE: This equipment has been tested and  
found to comply with the limits for a Class B digital  
device, pursuant to Part 15 of the FCC Rules.  
These limits are designed to provide reasonable  
protection against harmful interference in a  
residential installation. This equipment generates,  
uses and can radiate radio frequency energy  
and, if not installed and used in accordance with  
the instructions, may cause harmful interference  
to radio communications. However, there is no  
guarantee that interference will not occur in a  
particular installation. If this equipment does  
cause harmful interference to radio or television  
reception, which can be determined by turning the  
equipment off and on, the user is encouraged to  
try and correct the interference by one or more  
of the following measures:

Reorient or relocate the receiving antenna.

Increase the separation between the equipment  
and receiver.

Connect the equipment into an outlet on a  
circuit different from that to which the receiver  
is connected.

Consult the dealer or an experienced radio/TV  
technician for help.

Modifications to this product not authorized by  
CUSTOM S.p.A. could void the FCC & Industry  
Canada regulations and negate your authority to  
operate the product.



This product meets the ENERGY STAR®  
guidelines for energy efficiency.

For more information about ENERGY STAR®,  
visit [www.energystar.gov](http://www.energystar.gov).

This note is valid only for device bringing  
ENERGY STAR® trademark.

---

This Class B digital apparatus complies with  
Canadian ICES-003.

Cet appareil numérique de la classe B est  
conforme à la norme NMB-003 du Canada.

---

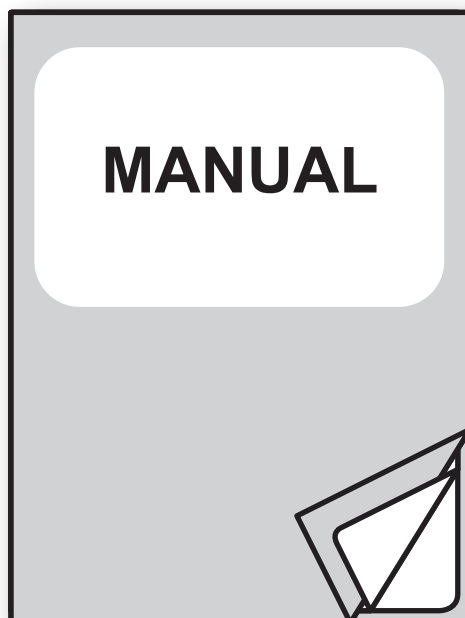

For details on the commands,  
refer to the manual with code **77200000001800**

For details about using of tool "PrinterSet",  
refer to the manual with code **78200000001800**.



# TABLE OF CONTENTS

1	INTRODUCTION .....	9
2	IDENTIFICATION OF THE MODELS .....	11
3	DESCRIPTION .....	13
3.1	Box contents .....	13
3.2	Device components: external views .....	19
3.3	Device components: keys and connectors panel .....	28
3.4	Device components: internal views .....	29
3.5	Device labels .....	33
3.6	Key functions: power up .....	34
3.7	Key functions: standby .....	35
3.8	Status messages .....	36
3.9	Display messages .....	37
4	INSTALLATION .....	39
4.1	Fastening .....	39
4.2	Low paper sensor .....	45
4.3	Connections .....	47
4.4	Pinout .....	48
4.5	Driver and SDK .....	51
5	OPERATION .....	53
5.1	Opening device cover .....	53
5.2	Adjusting device for 82.5 mm paper width .....	55
5.3	Adjusting device for 80 mm paper width .....	56
5.4	Adjusting device for 54 mm paper width .....	57
5.5	Adjusting device for 20 mm to 25 mm paper width .....	60
5.6	Adjusting device for other paper width .....	61
5.7	Adjusting the alignment sensors .....	62
5.8	Switch the device on .....	64
5.9	Loading the paper roll .....	73
5.10	Issuing ticket .....	77
5.11	License activation for RFID tag reading .....	79

<b>6</b>	<b>CONFIGURATION</b>	<b>81</b>
6.1	Configuration by keys	81
6.2	Configuration by software	84
6.3	Configuration by file	86
6.4	Printhead status	88
6.5	Device status	89
6.6	Communication parameters	90
6.7	Operation parameters	92
6.8	Alignment parameters	95
6.9	Hexadecimal dump	97
<b>7</b>	<b>ALIGNMENT</b>	<b>99</b>
7.1	Enable alignment	100
7.2	Calibration	103
7.3	Alignment parameters	106
7.4	Printing area	110
<b>8</b>	<b>MAINTENANCE</b>	<b>111</b>
8.1	Printer paper jam	111
8.2	Autocutter paper jam	112
8.3	Planning of cleaning operations	114
8.4	Cleaning	116
8.5	Upgrade firmware	122
<b>9</b>	<b>SPECIFICATION</b>	<b>123</b>
9.1	Hardware specifications	123
9.2	Character specifications	129
9.3	Device dimensions	130
9.4	Device dimensions with pretensioner modules	139
9.5	Device dimensions with paper roll holder	141
9.6	Device dimensions with paper roll holder	145
9.7	Device dimensions with ticket tray	147
9.8	Device dimensions with ticket tray	149
9.9	Dimensions of power supply and power cord	150
9.10	Paper specification	152
9.11	Character sets in CUSTOM/POS emulation	156
9.12	Character sets in SVELTA emulation	158
<b>10</b>	<b>CONSUMABLES</b>	<b>159</b>
<b>11</b>	<b>ACCESSORIES</b>	<b>161</b>
<b>12</b>	<b>TECHNICAL SERVICE</b>	<b>167</b>





# 1 INTRODUCTION

This document is divided into sections and chapters. Each chapter can be reached by the index at the beginning of this document. The index can be reached by the button on each page as shown in the diagram below.

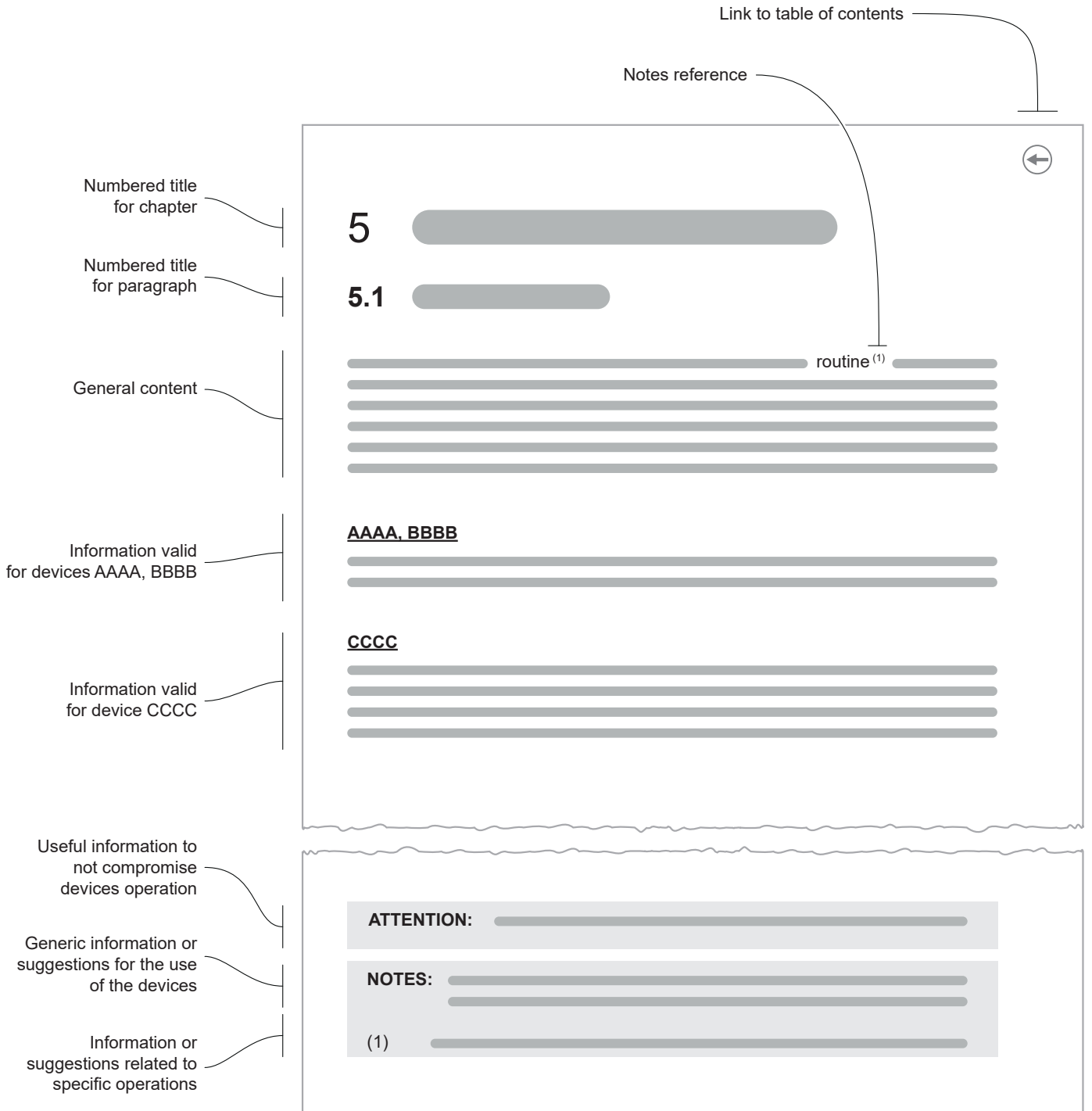





## 2 IDENTIFICATION OF THE MODELS

NOMENCLATURE	DESCRIPTION
KPM180H 1	KPM180H base configuration
KPM180H 2	KPM180H with autocutter and presenter
KPM180H 3	KPM180H with autocutter, presenter and external RFID reader/writer
KPM180H 4	KPM180H with autocutter and presenter (linerless model)
KPM180H 5	KPM180H with autocutter, presenter and external RFID reader/writer (linerless model)
KPM180H 6	KPM180H with autocutter, presenter and internal RFID reader/writer (linerless model)
TK180 MET 1	TK180 with metal chassis
TK180 MET 2	TK180 with metal chassis and external RFID reader/writer
TK180 MET 3	TK180 with metal chassis and internal RFID reader/writer (linerless model)
TK180 CUT 1	TK180 with metal chassis, autocutter and presenter
TK180 CUT 2	TK180 with metal chassis, autocutter, presenter and external RFID reader/writer
TK180 CUT 3	TK180 with metal chassis, autocutter, presenter and internal RFID reader/writer (linerless model)
TK180 PLAS 1	TK180 with plastic chassis
TK180 PLAS 2	TK180 with plastic chassis and external RFID reader/writer
TK180 PLAS 3	TK180 with plastic chassis and internal RFID reader/writer (linerless model)



# 3 DESCRIPTION

## 3.1 Box contents

Remove all the box contents (see following figures) being careful not to damage the packing material so that it may be re-used if the device is to be transported in the future.

Make sure that all the components illustrated below are present and that there are no signs of damage. If there are, contact customer service.

**KPM180H 1, KPM180H 2, KPM180H 3**  
**KPM180H 4, KPM180H 5**

1. Documentation (installation instruction sheet)
2. Cable for low paper sensor
3. Board for external low paper sensor
4. Reducer for paper width
5. Paper block guide
6. Device

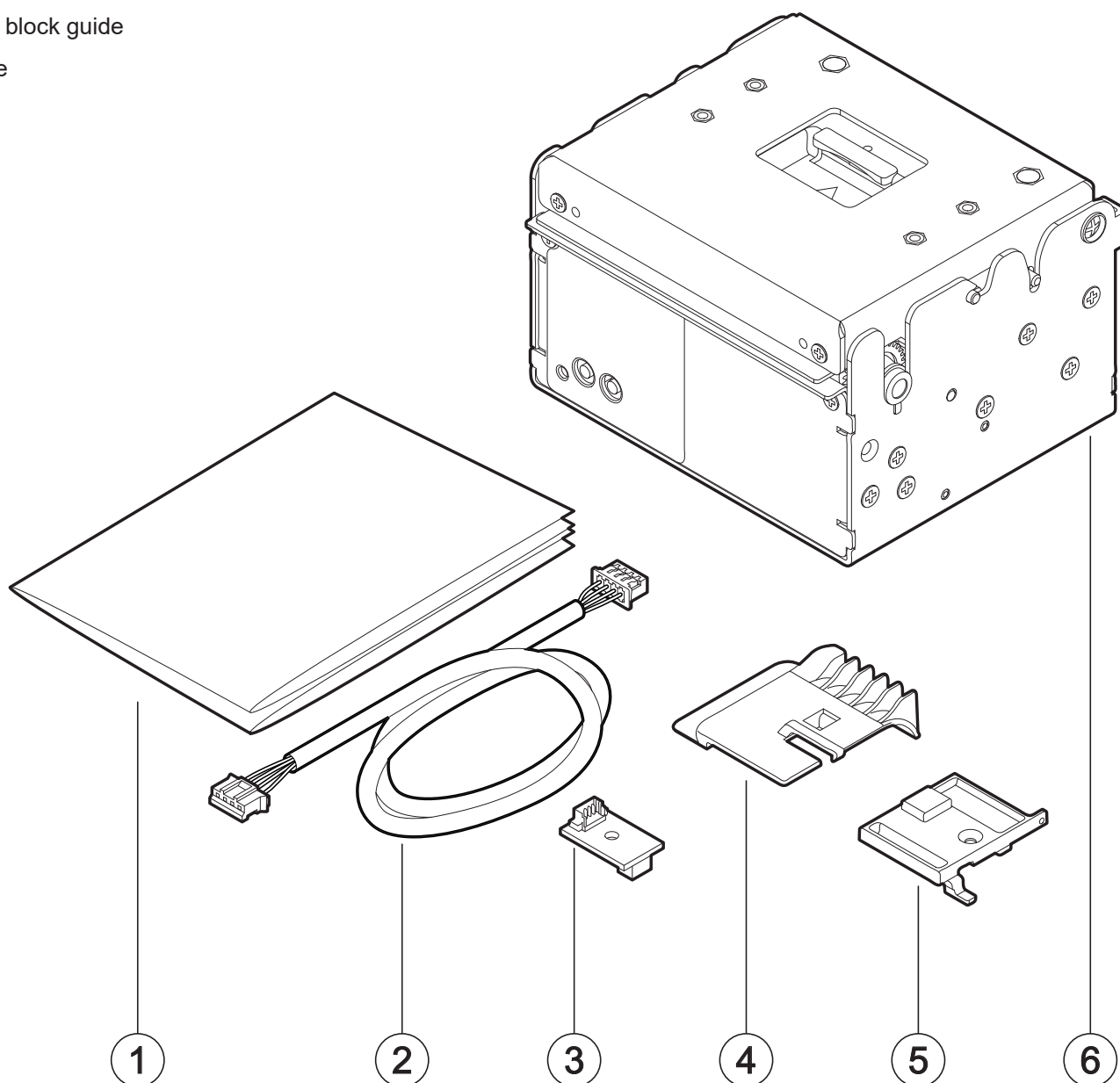



**KPM180H 6**

1. Documentation (installation instruction sheet)
2. Cable for low paper sensor
3. Board for external low paper sensor
4. Paper block guide
5. Screw for paper block guide fixing
6. Device

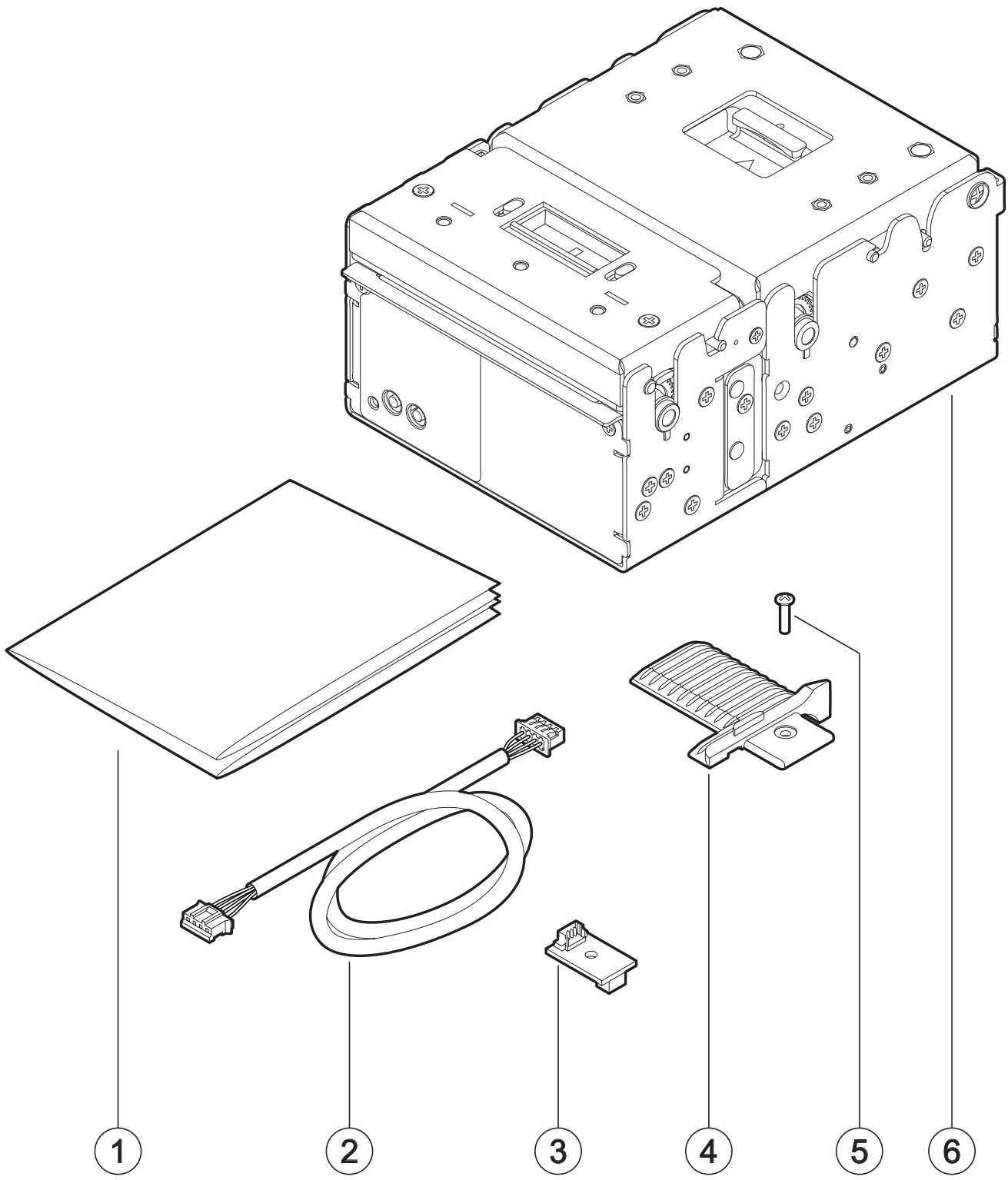



**TK180 MET 1, TK180 MET 2**  
**TK180 CUT 1, TK180 CUT 2**

1. Documentation (short guide)
2. AC power cord
3. AC adapter
4. Paper block guide
5. Reducer for paper width
6. Device

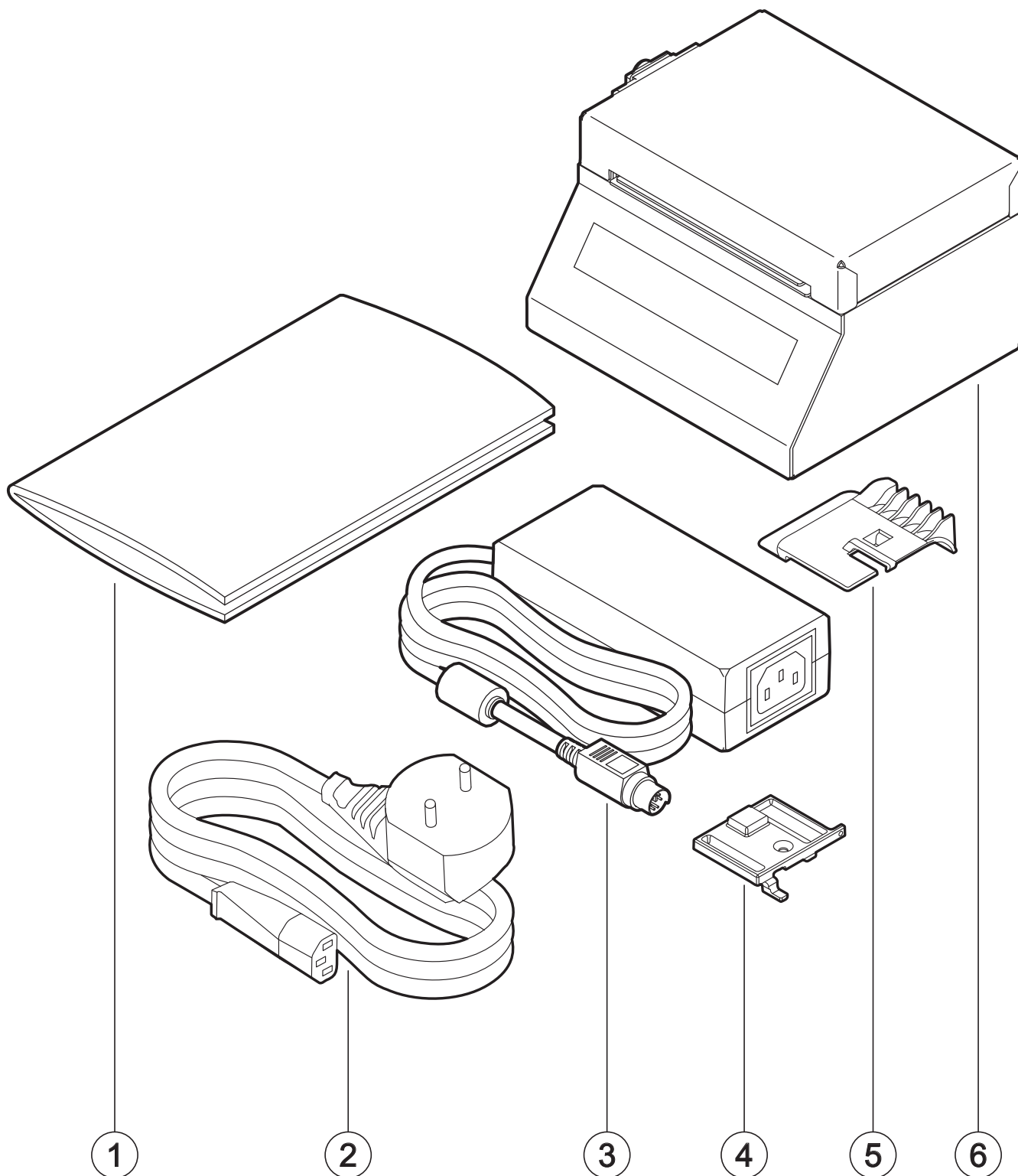



**TK180 MET 3**  
**TK180 CUT 3**

1. Documentation (short guide)
2. AC power cord
3. Paper block guide
4. Screw for paper block guide fixing
5. AC adapter
6. Device

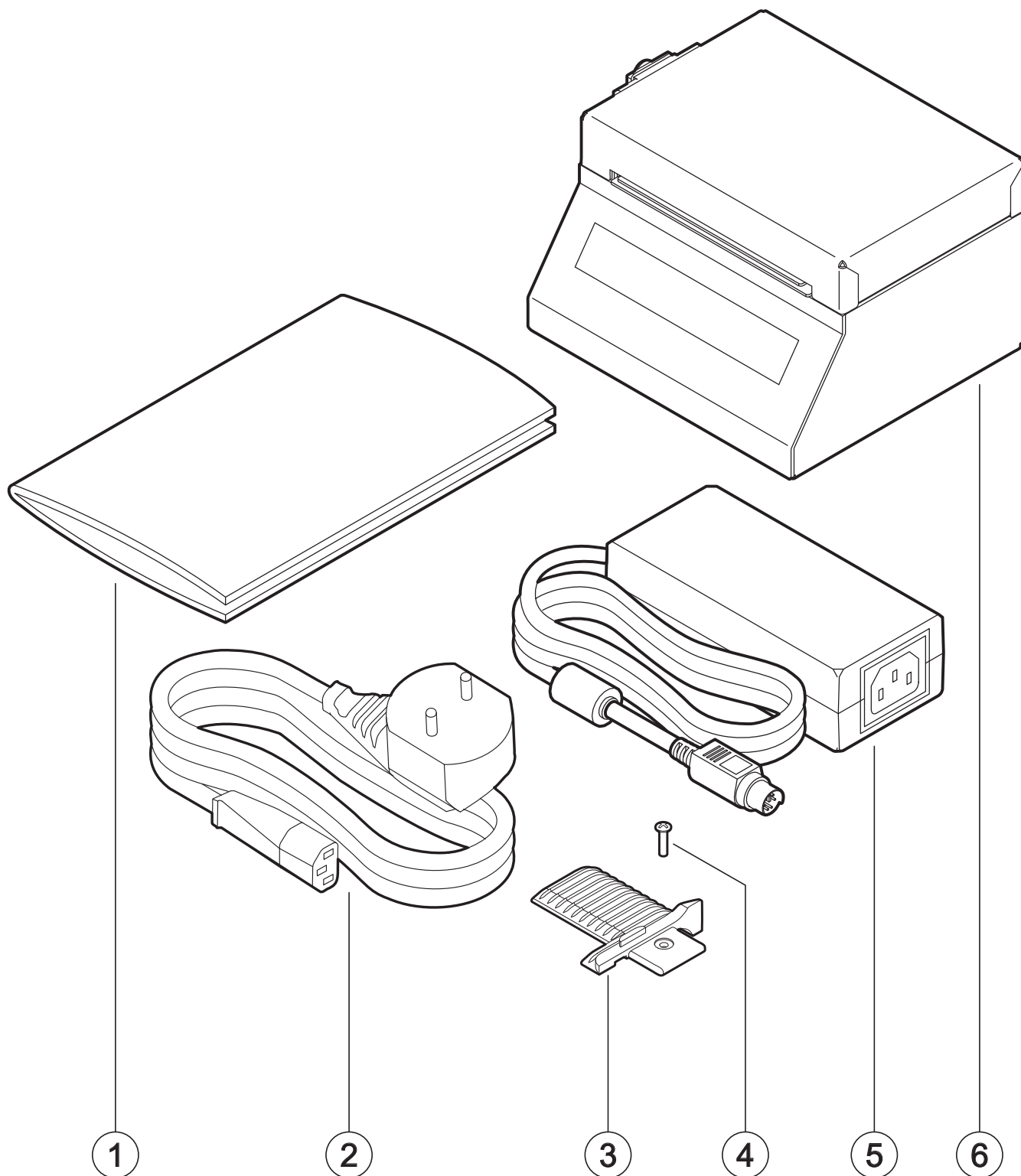





**TK180 PLAS 1, TK180 PLAS 2**

1. Documentation (short guide)
2. AC power cable
3. AC adapter
4. Paper block guide
5. Reducer for paper width
6. Device

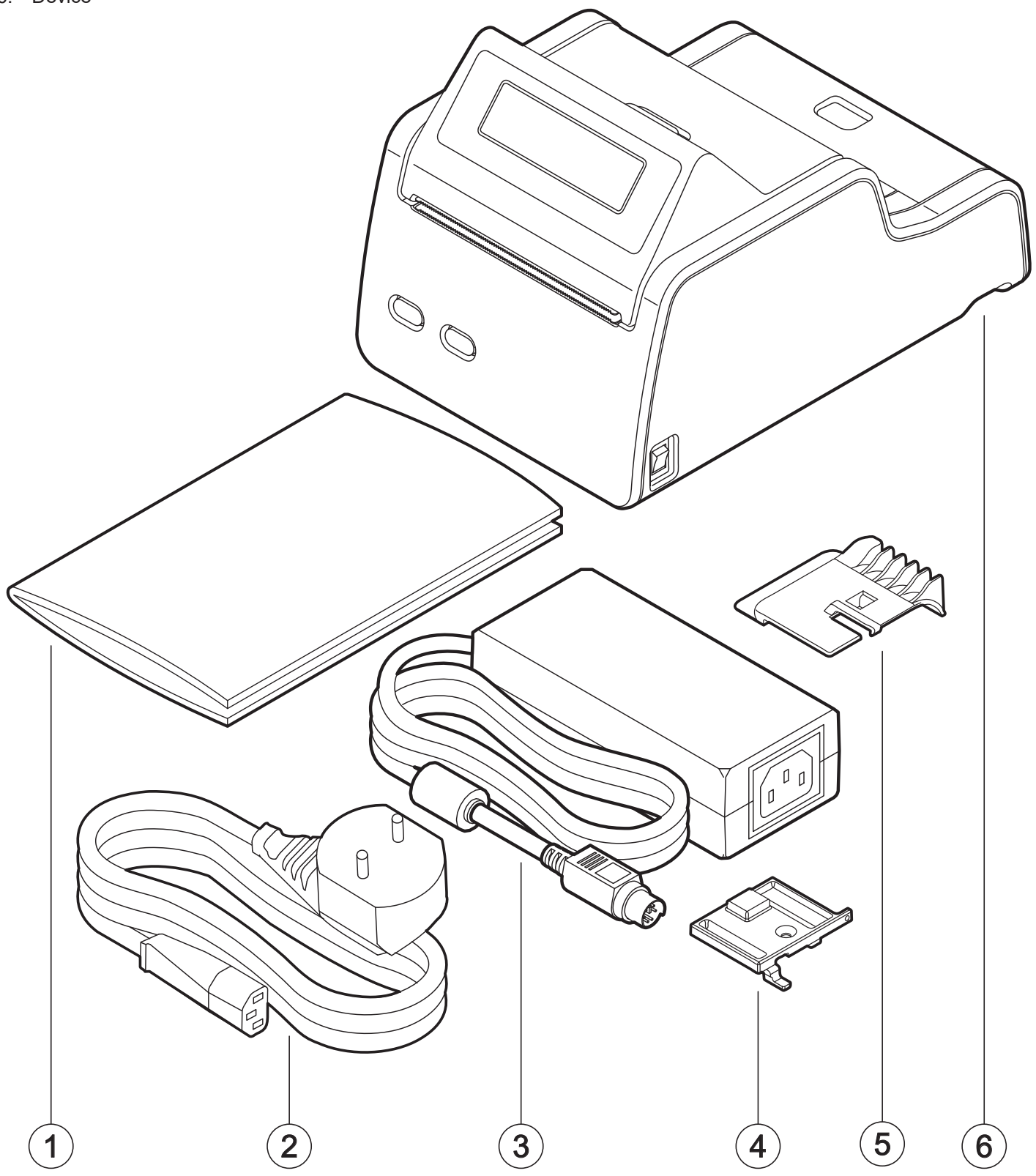



### **TK180 PLAS 3**

1. Documentation (short guide)
2. AC power cable
3. Paper block guide
4. Screw for paper block guide fixing
5. AC adapter
6. Device

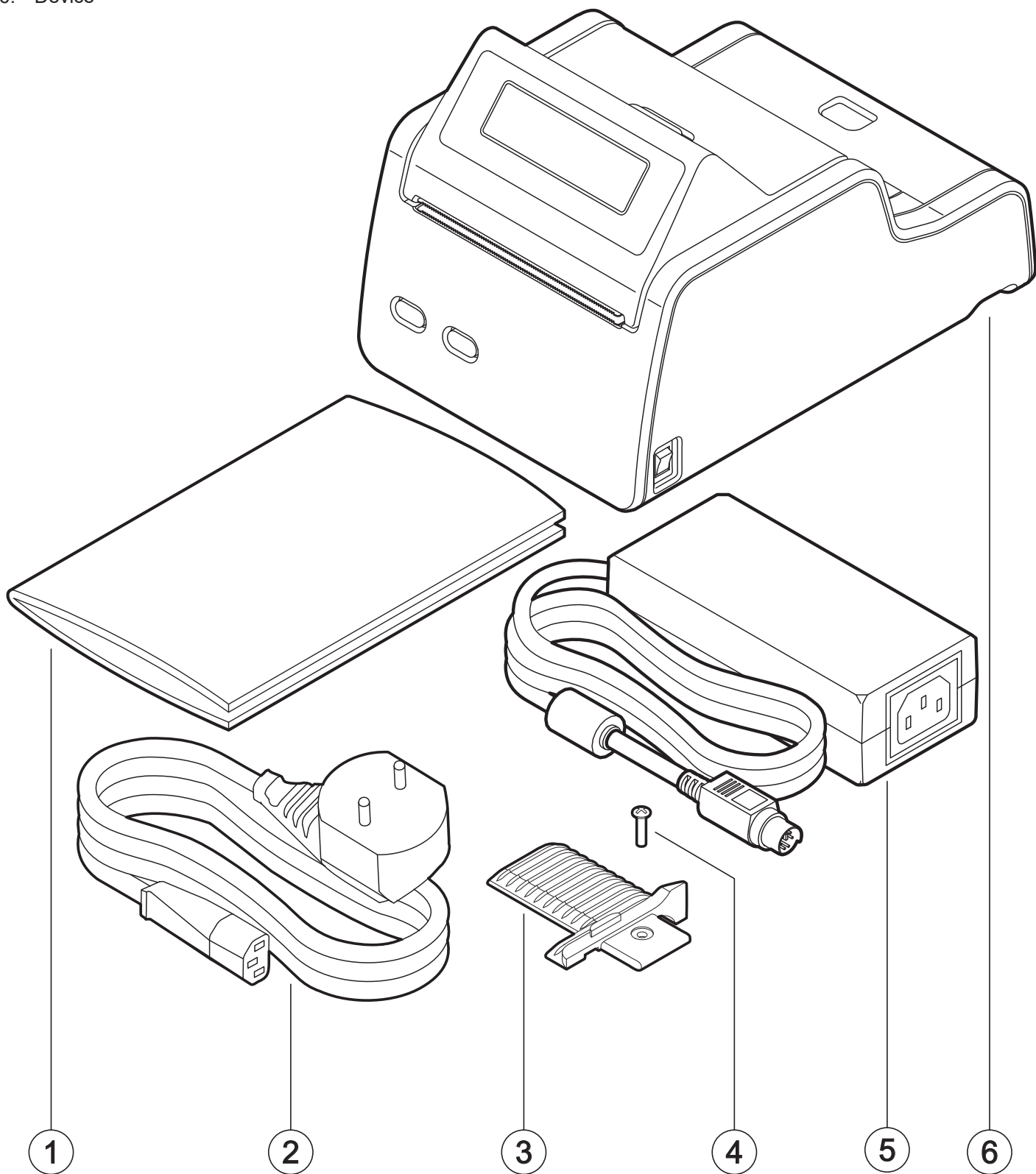



## 3.2 Device components: external views

### KPM180H 1

1. Device chassis
2. Device cover
3. Opening lever for device cover
4. Paper out
5. Status LED
6. LF LINE FEED key
7. FF FORM FEED key
8. Paper input
9. Keys and connectors panel  
(see [paragraph 3.3](#))
10. Product label

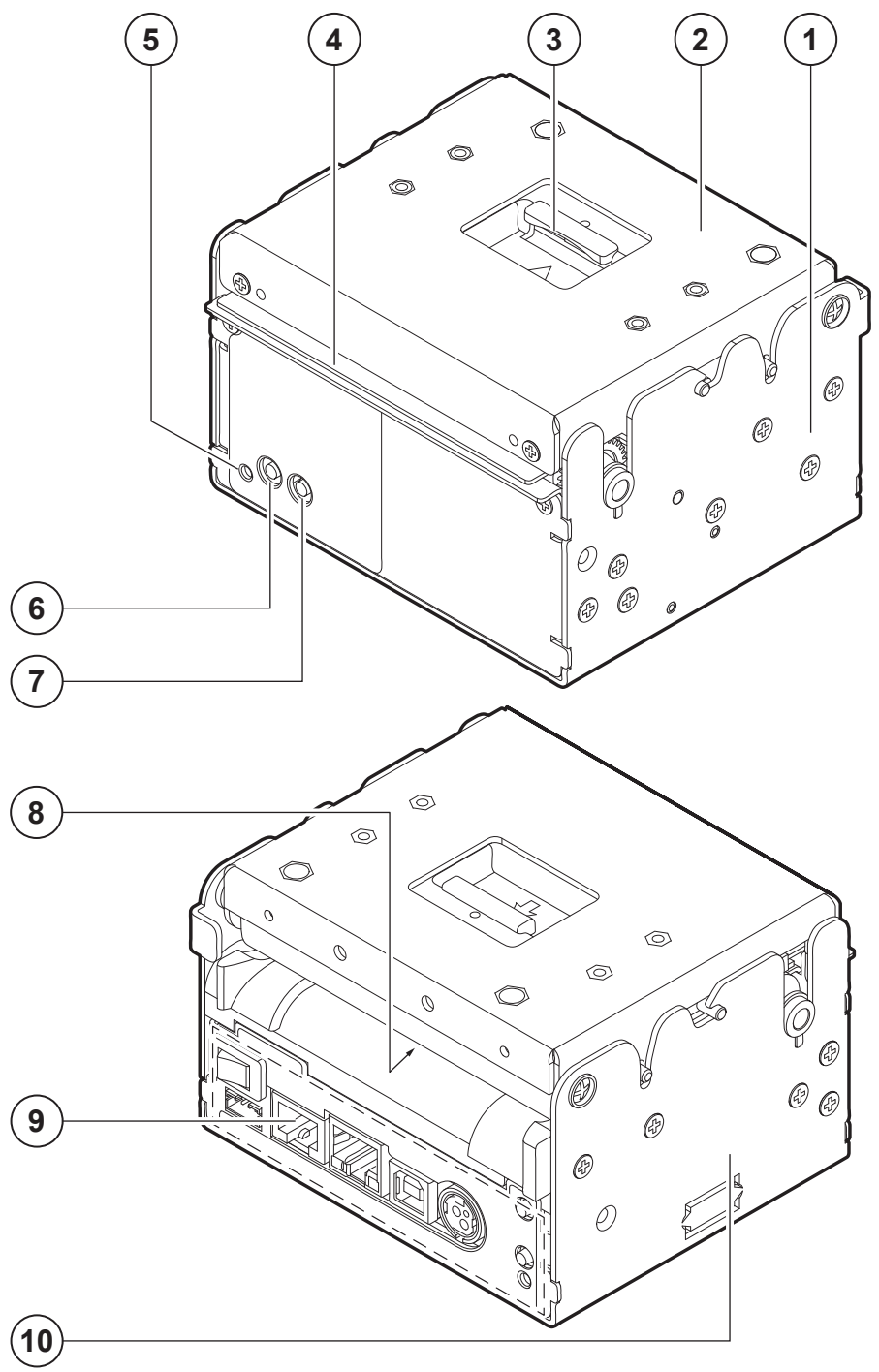



**KPM180H 2, KPM180H 4, KPM180H 6**

1. Device chassis
2. Device cover
3. Opening lever for printer group cover
4. Autocutter
5. Release lever for presenter group cover
6. Paper out
7. Status LED
8. LF LINE FEED key
9. FF FORM FEED key
10. Presenter group
11. RFID antenna  
(only for KPM180H 6)
12. Paper input
13. Keys and connectors panel  
(see [paragraph 3.3](#))
14. Product label

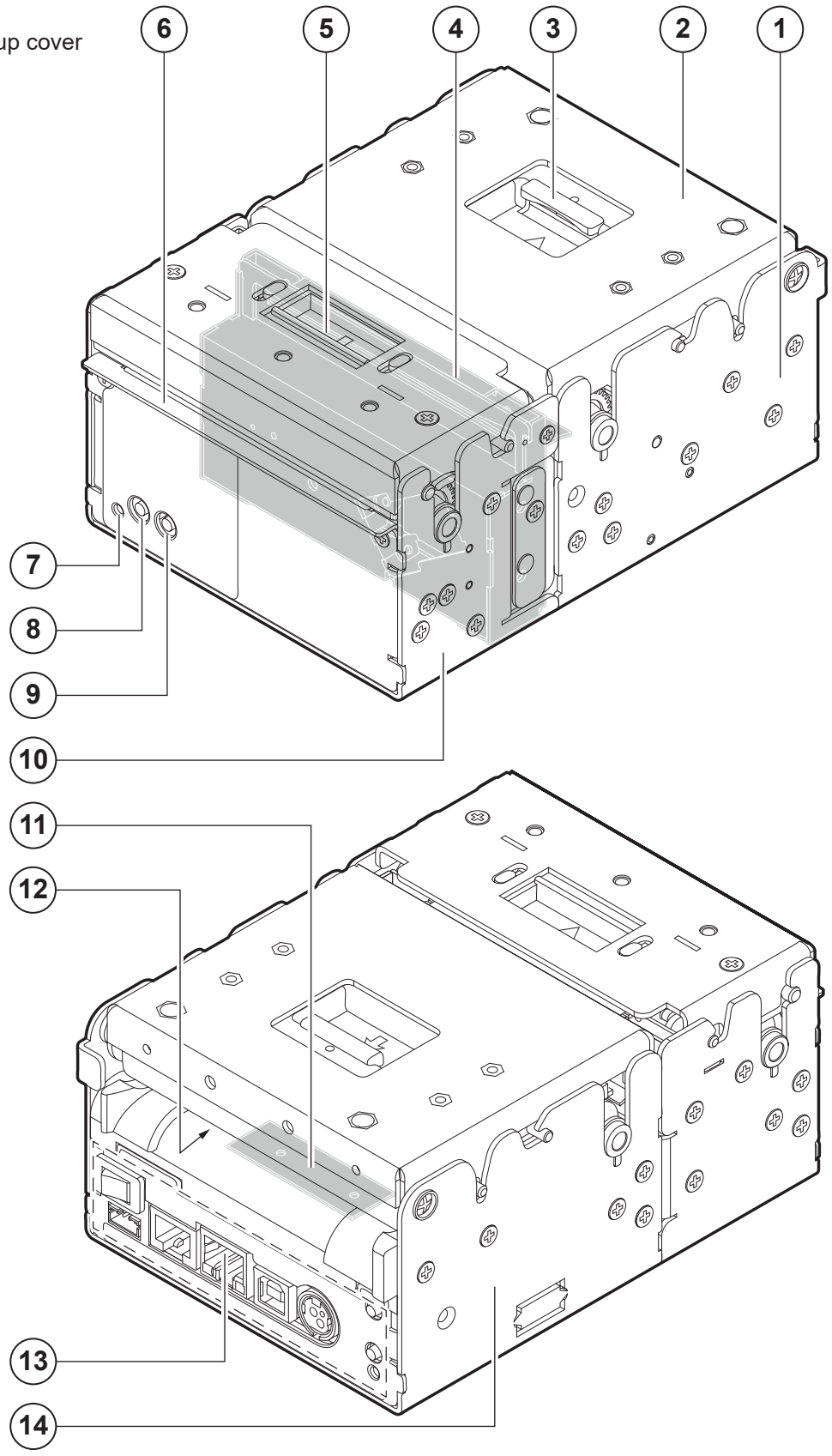

### **KPM180H 3, KPM180H 5**

1. RFID reader
2. Device cover
3. Opening lever for printer group cover
4. Autocutter
5. Release lever for presenter group cover
6. Paper out
7. Status LED
8. LF LINE FEED key
9. FF FORM FEED key
10. Presenter group
11. Device chassis
12. Paper input
13. Keys and connectors panel  
(see [paragraph 3.3](#))
14. Product label

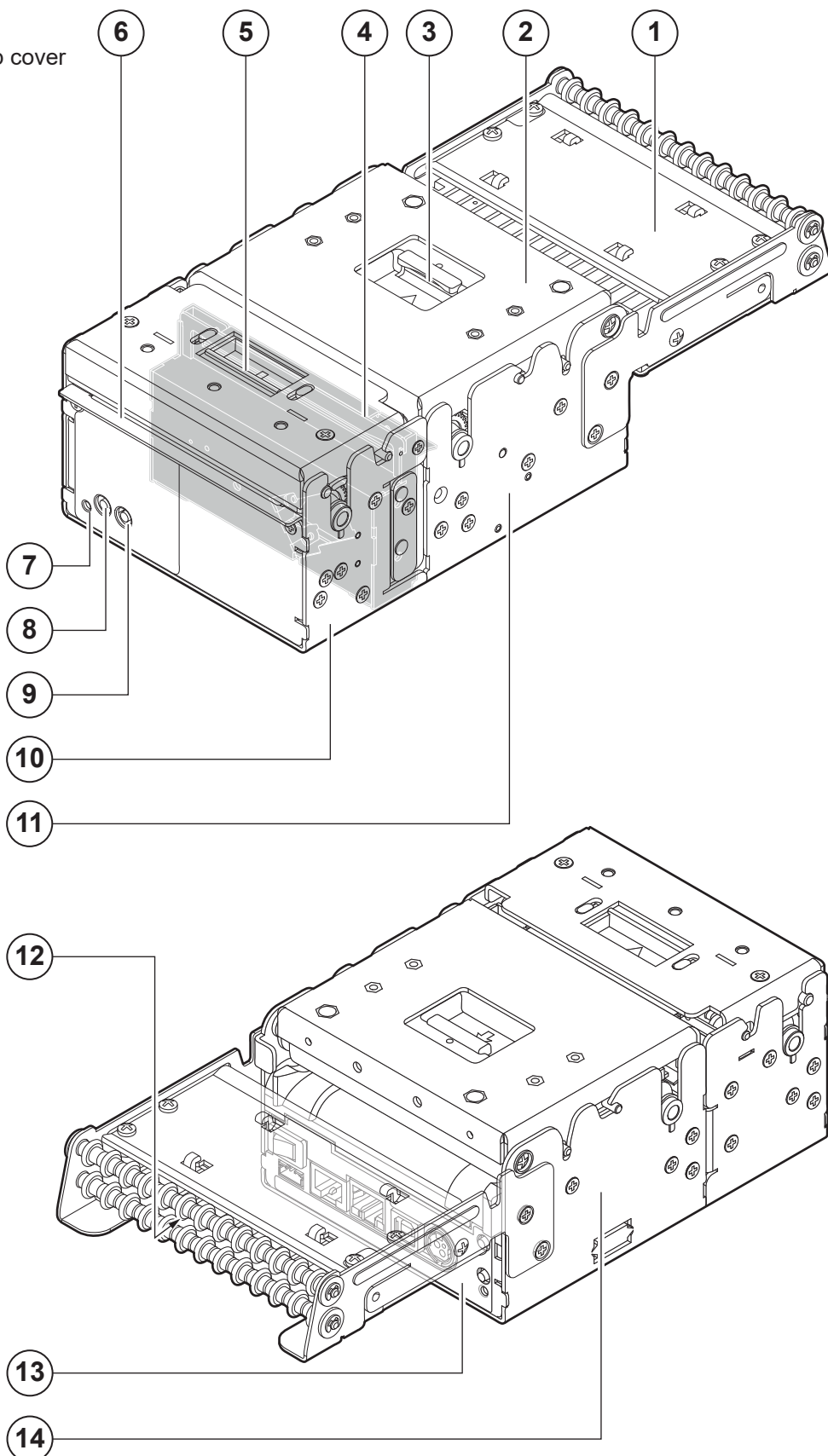



## **TK180 MET 1, TK180 MET 3**

1. Device chassis
2. Device cover
3. Paper out
4. Display
5. RFID antenna  
(only for TK180 MET 3)
6. Paper input
7. Keys and connectors panel  
(see [paragraph 3.3](#))

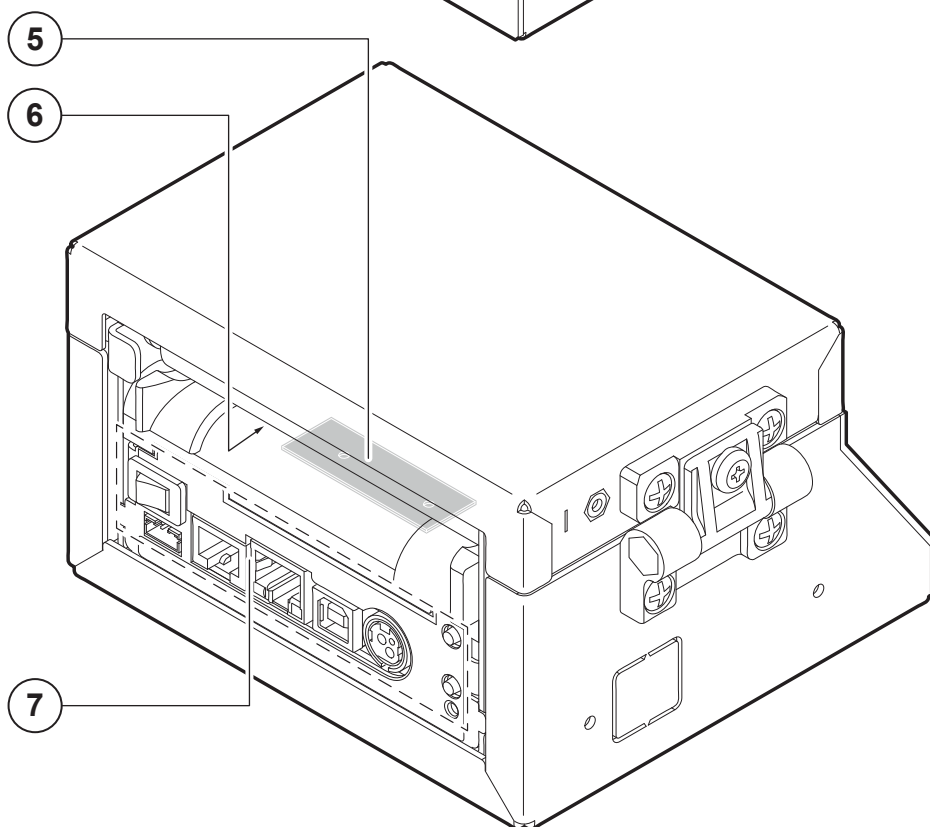
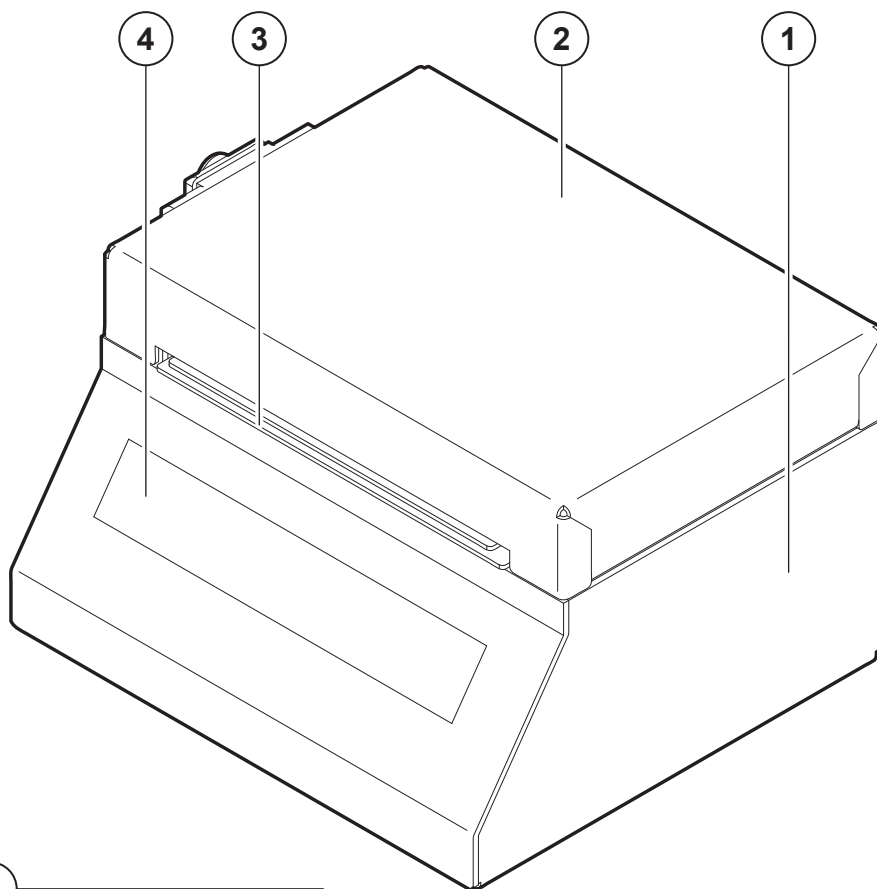



## **TK180 CUT 1, TK180 CUT 3**

1. Device chassis
2. Device cover
3. Autocutter
4. Display
5. Paper out
6. RFID antenna  
(only for TK180 CUT 3)
7. Paper input
8. Keys and connectors panel  
(see [paragraph 3.3](#))

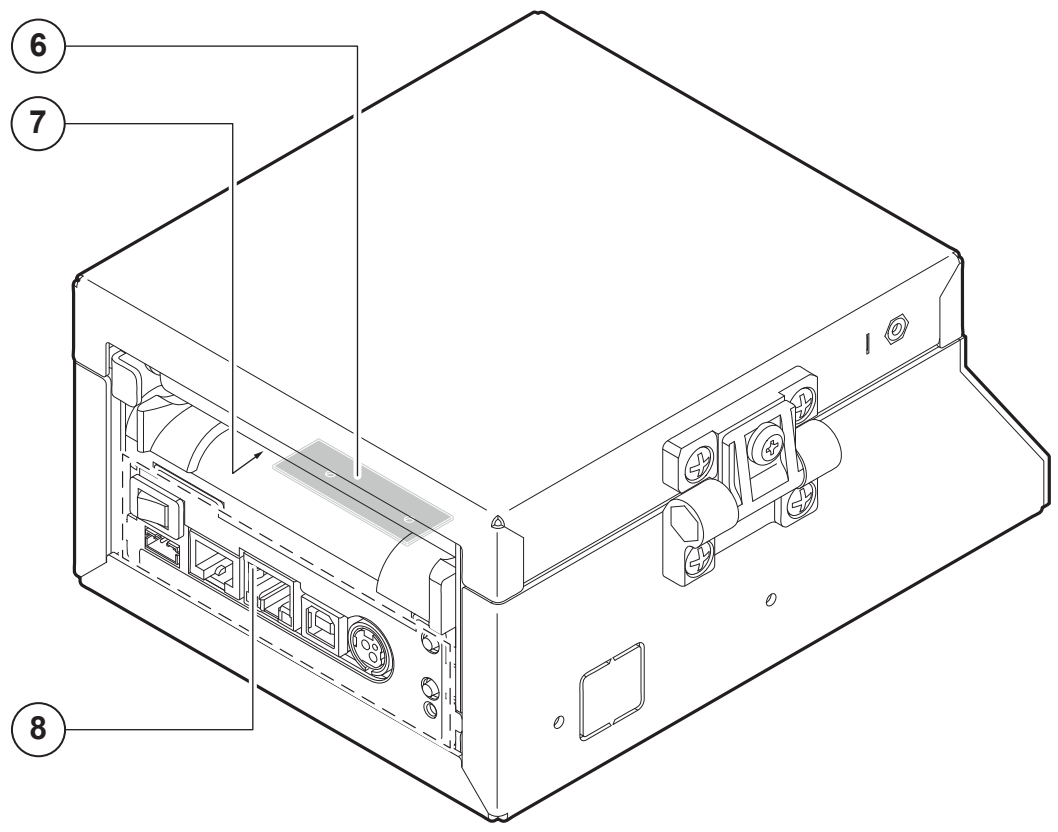
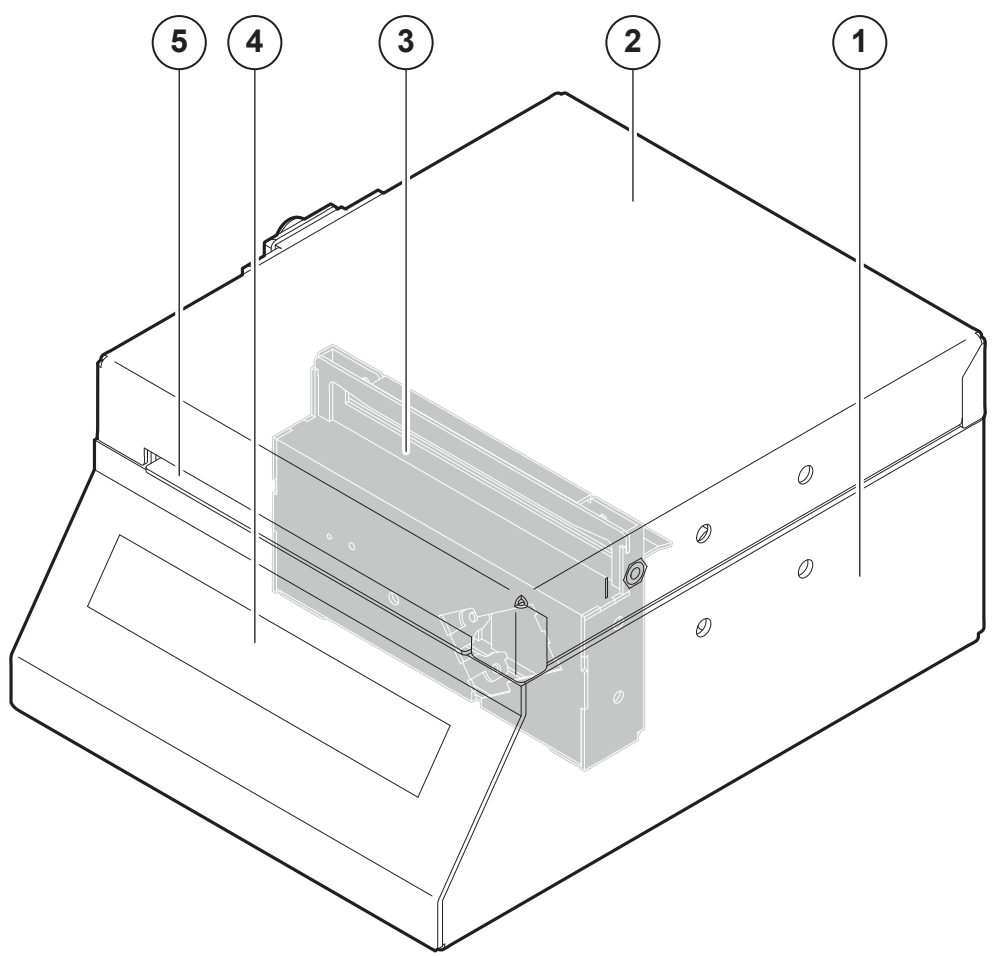



## TK180 CUT 2

1. RFID reader
2. Device chassis
3. Device cover
4. Autocutter
5. Display
6. Paper out
7. Paper input
8. Keys and connectors panel  
(see [paragraph 3.3](#))

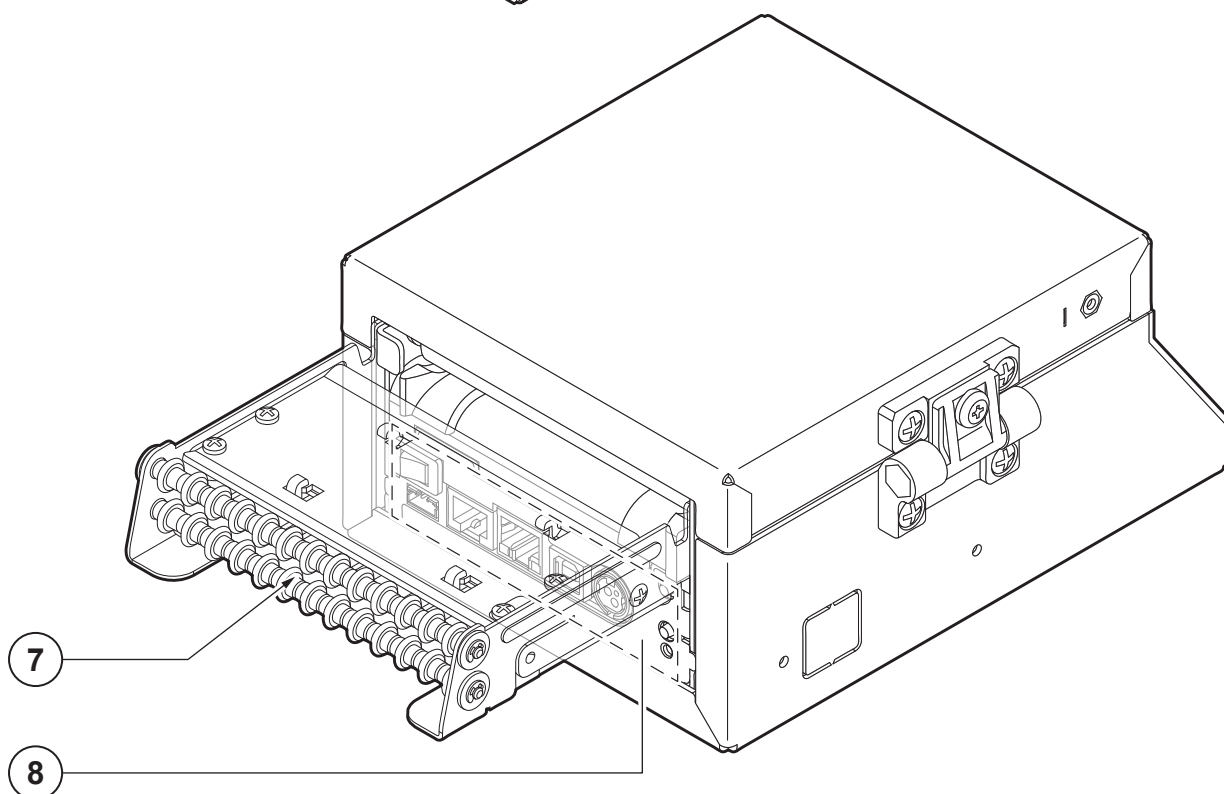
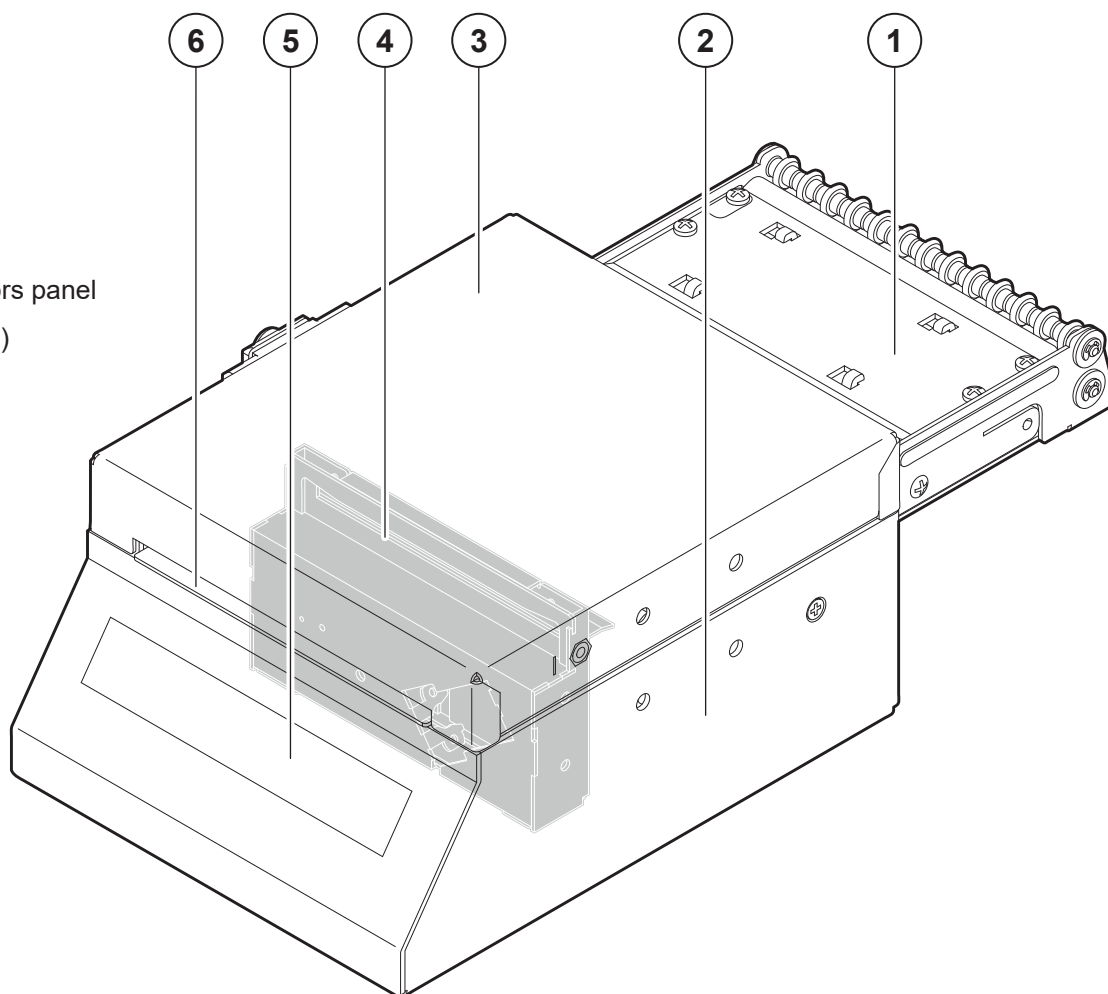





## **TK180 MET 2**

1. RFID reader
2. Device chassis
3. Device cover
4. Paper out
5. Display
6. Paper input
7. Keys and connectors panel  
(see [paragraph 3.3](#))

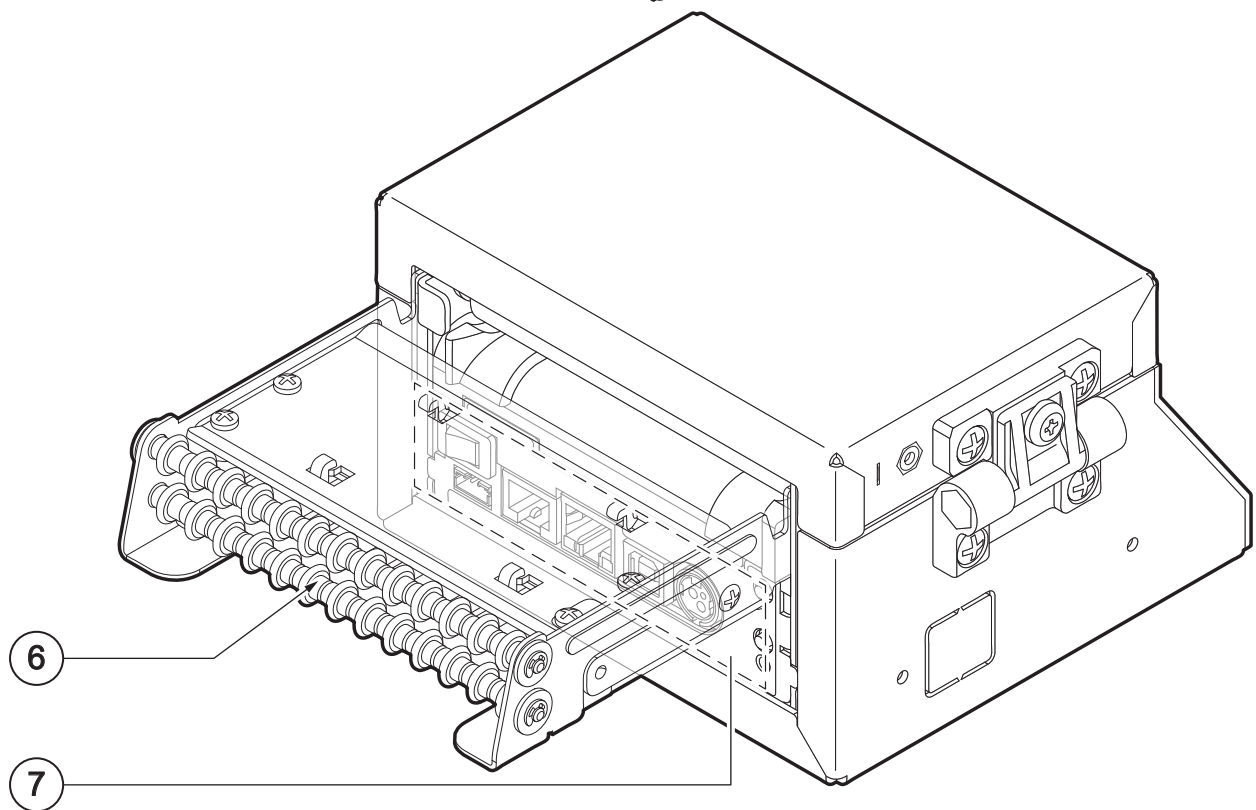
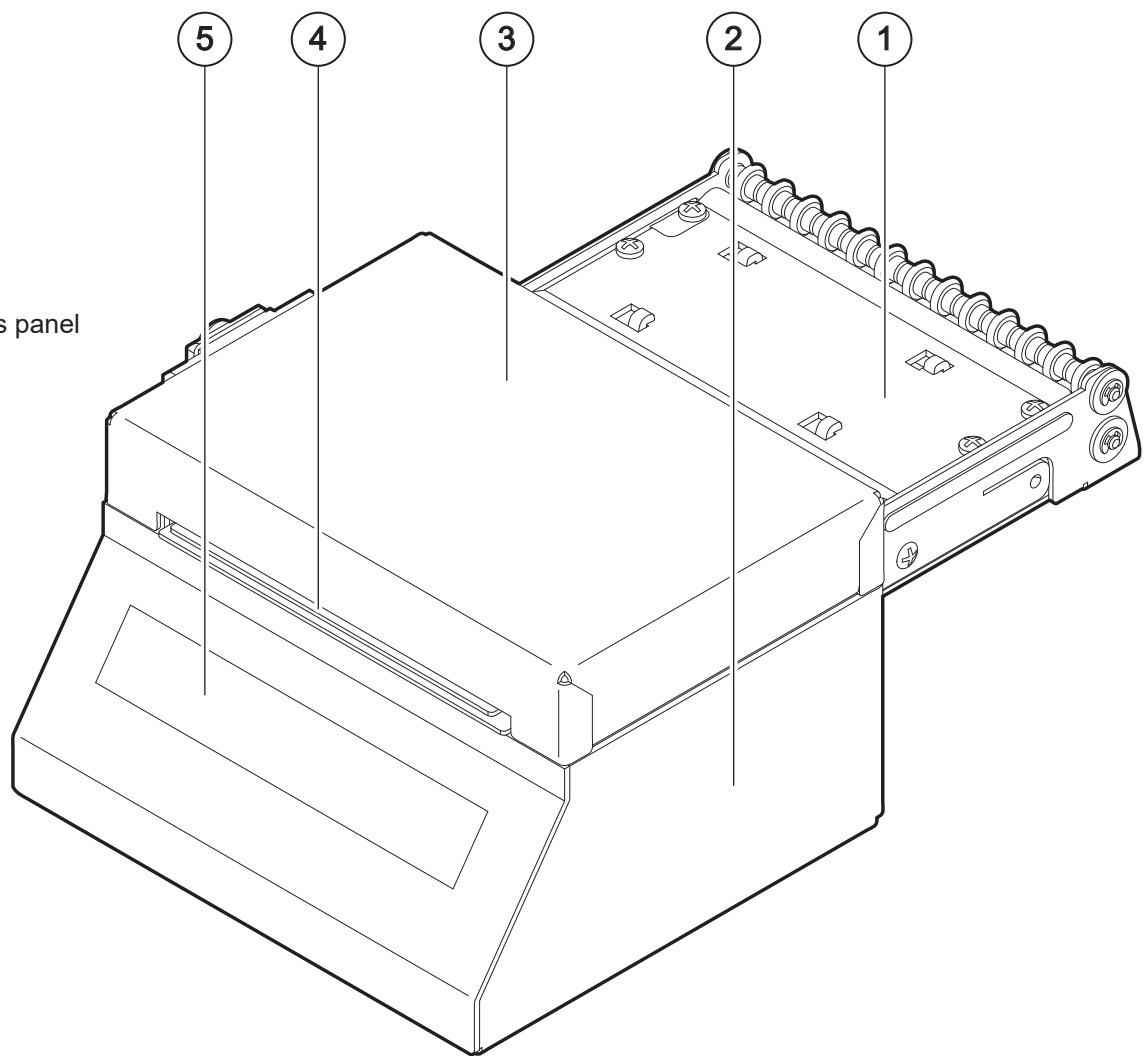



## **TK180 PLAS 1, TK180 PLAS 3**

1. Connectors cover
2. Device cover
3. Display
4. Paper out
5. LF LINE FEED key
6. FF FORM FEED key
7. ON/OFF key
8. Opening lever for device cover
9. RFID antenna  
(only for TK180 PLAS 3)
10. Paper input
11. Keys and connectors panel  
(see [paragraph 3.3](#))

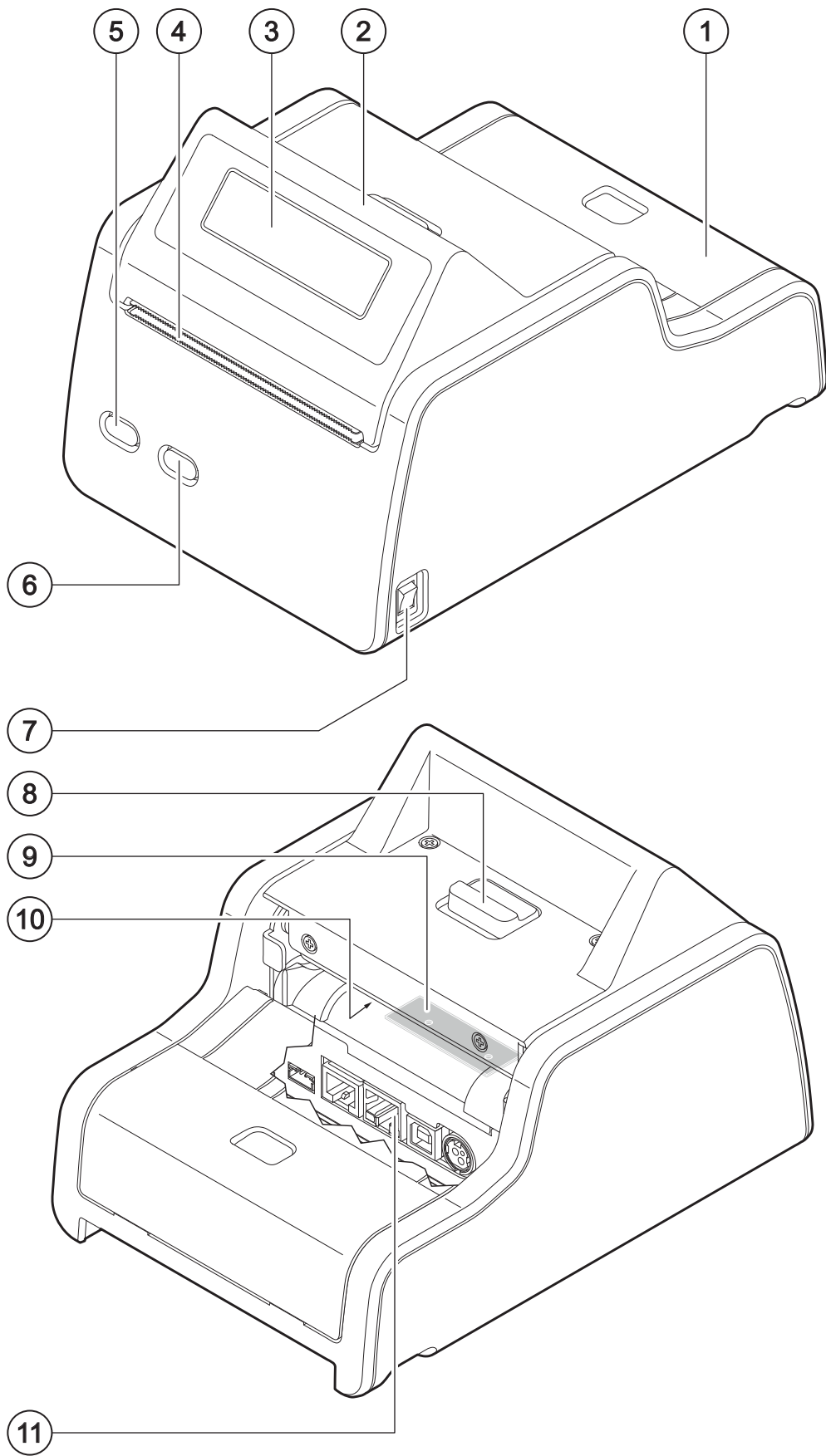



## **TK180 PLAS 2**

1. RFID reader
2. Display
3. Paper out
4. LF LINE FEED key
5. FF FORM FEED key
6. ON/OFF key
7. Device cover
8. Opening lever for device cover
9. Paper input
10. Keys and connectors panel  
(see [paragraph 3.3](#))

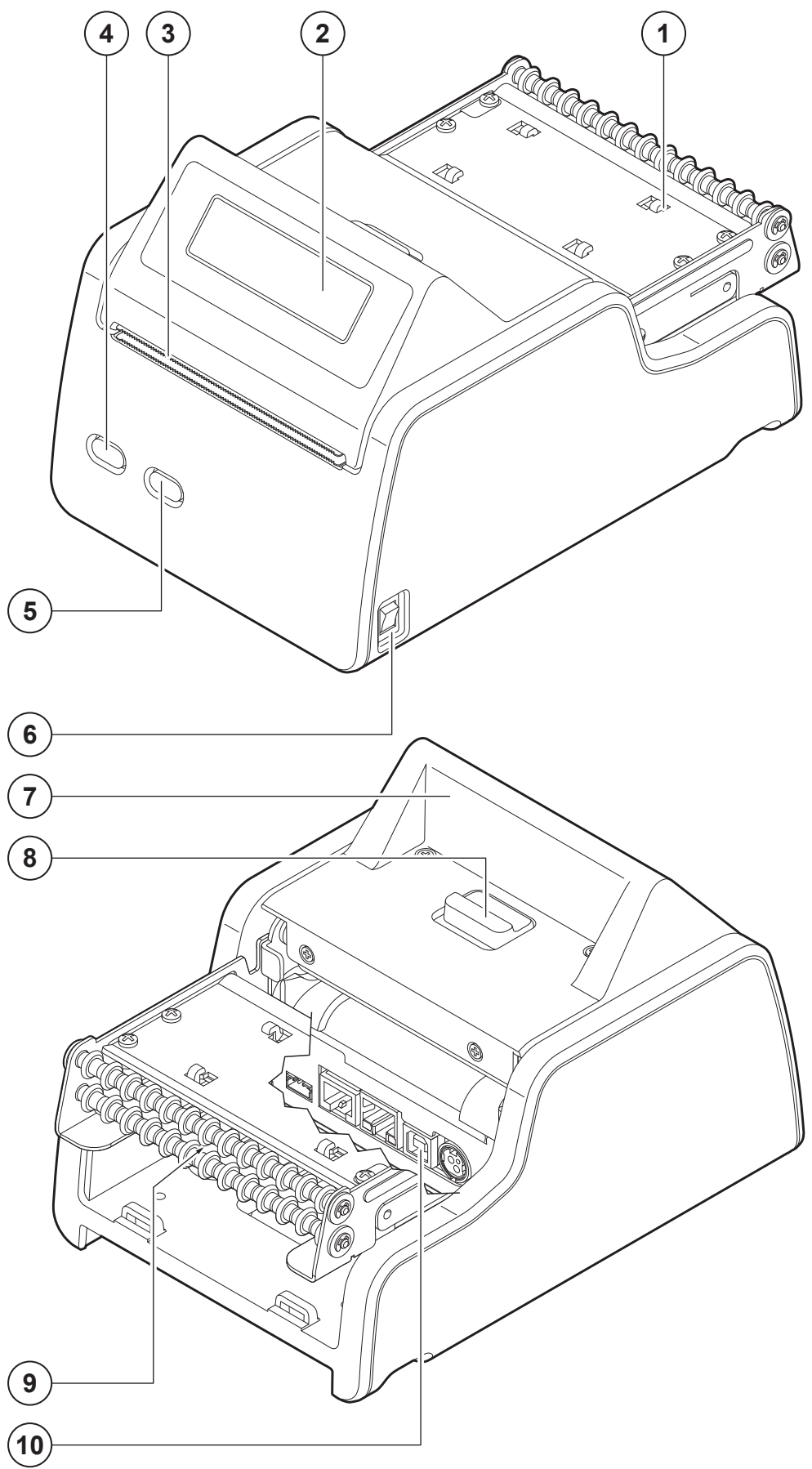

### 3.3 Device components: keys and connectors panel

1. ON/OFF key (except for TK180 PLAS 1, TK180 PLAS 2, TK180 PLAS 3)
2. Connector for low paper sensor (external)
3. RS232 serial port (RJ45)
4. Ethernet port
5. USB port
6. Power supply port
7. Status LED
8. FF FORM FEED key
9. LF LINE FEED key

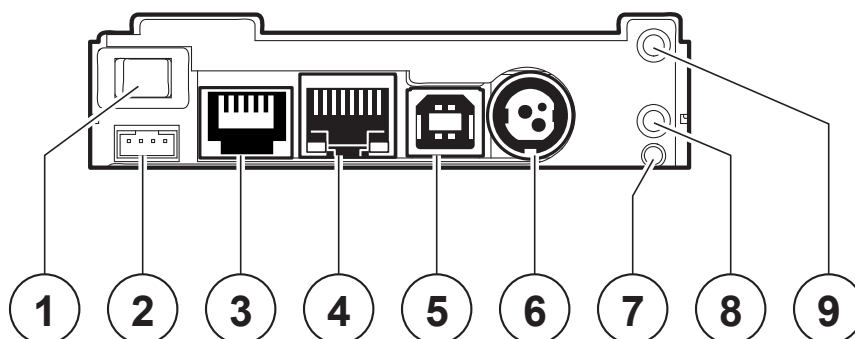

### 3.4 Device components: internal views

KPM180H 1

TK180 MET 1, TK180 MET 2

TK180 PLAS 1, TK180 PLAS 2

1. Printhead with temperature sensor
2. Top mobile sensor for detecting black mark on the thermal side of paper or hole between tickets
3. Sensors for detecting paper in presence
4. Sensor for cover opening detection
5. Bottom mobile sensor for detecting black mark on the thermal side of paper or hole between tickets
6. Sensors for detecting paper out presence
7. Adjustable cursor for paper in

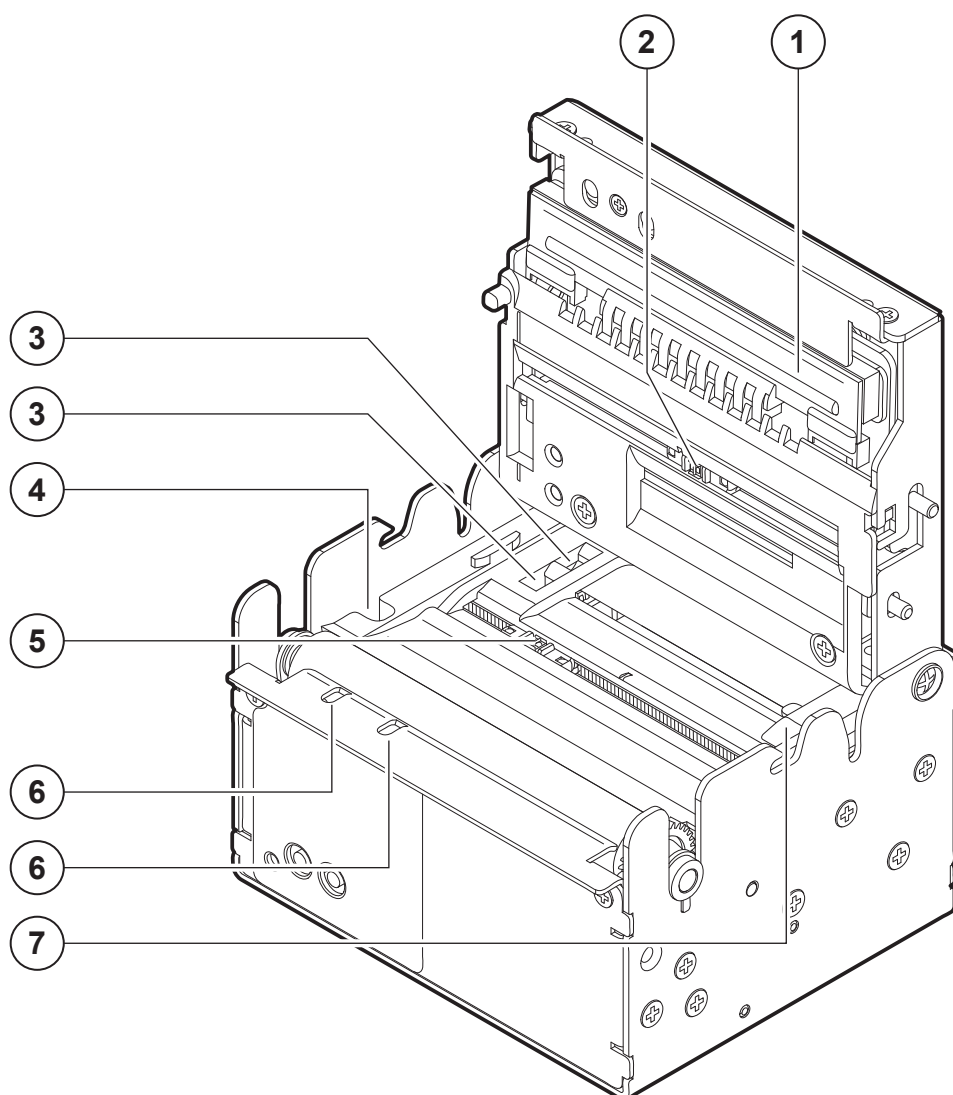



**TK180 MET 3**  
**TK180 PLAS 3**

1. Printhead with temperature sensor
2. Top mobile sensor for detecting black mark on the thermal side of paper or hole between tickets
3. Sensors for detecting paper in presence
4. Sensor for cover opening detection
5. Bottom mobile sensor for detecting black mark on the thermal side of paper or hole between tickets
6. Sensors for detecting paper out presence
7. Adjustable cursor for paper in

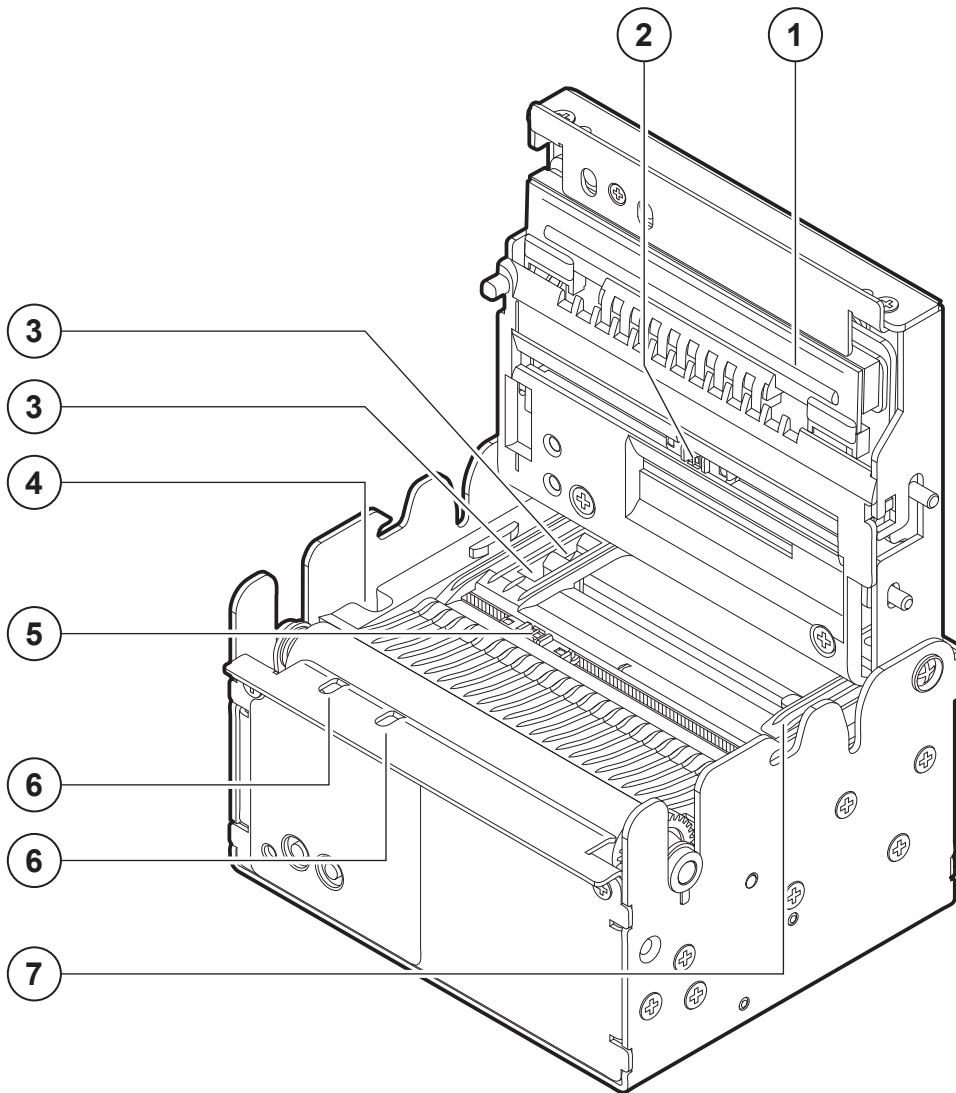



**KPM180H 2, KPM180H 3, KPM180H 4, KPM180H 5**  
**TK180 CUT 1, TK180 CUT 2**

1. Printhead with temperature sensor
2. Top mobile sensor for detecting black mark on the thermal side of paper or hole between tickets
3. Sensors for detecting paper in presence
4. Bottom mobile sensor for detecting black mark on the thermal side of paper or hole between tickets
5. Sensor for detecting the opening of the printer group cover
6. Sensor for detecting the release of the presenter group cover
7. Sensors for detecting paper out presence
8. Adjustable cursor for paper in

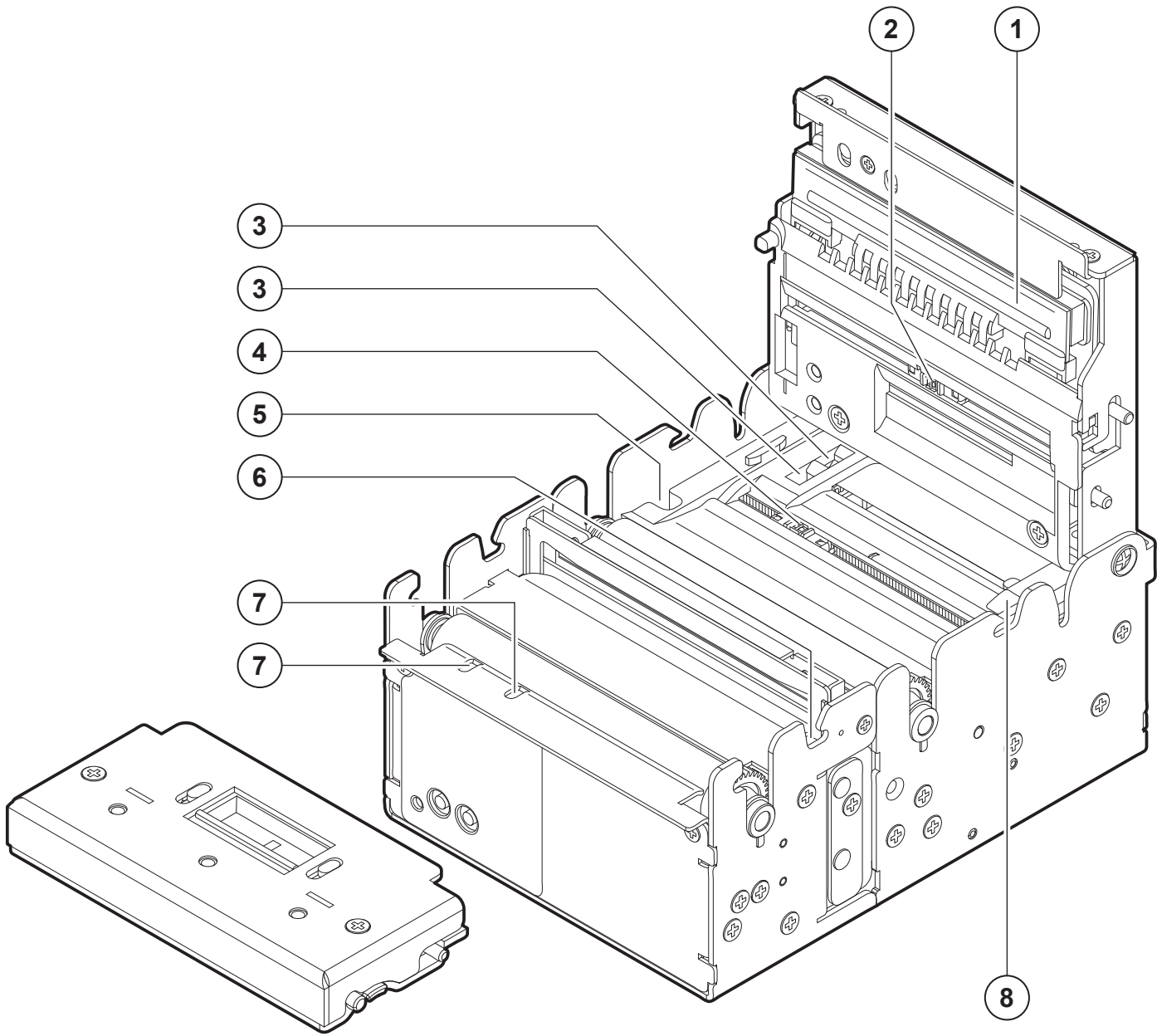



**KPM180H 6**  
**TK180 CUT 3**

1. Printhead with temperature sensor
2. Top mobile sensor for detecting black mark on the thermal side of paper or hole between tickets
3. Sensors for detecting paper in presence
4. Bottom mobile sensor for detecting black mark on the thermal side of paper or hole between tickets
5. Sensor for detecting the opening of the printer group cover
6. Sensor for detecting the release of the presenter group cover
7. Sensors for detecting paper out presence
8. Adjustable cursor for paper in

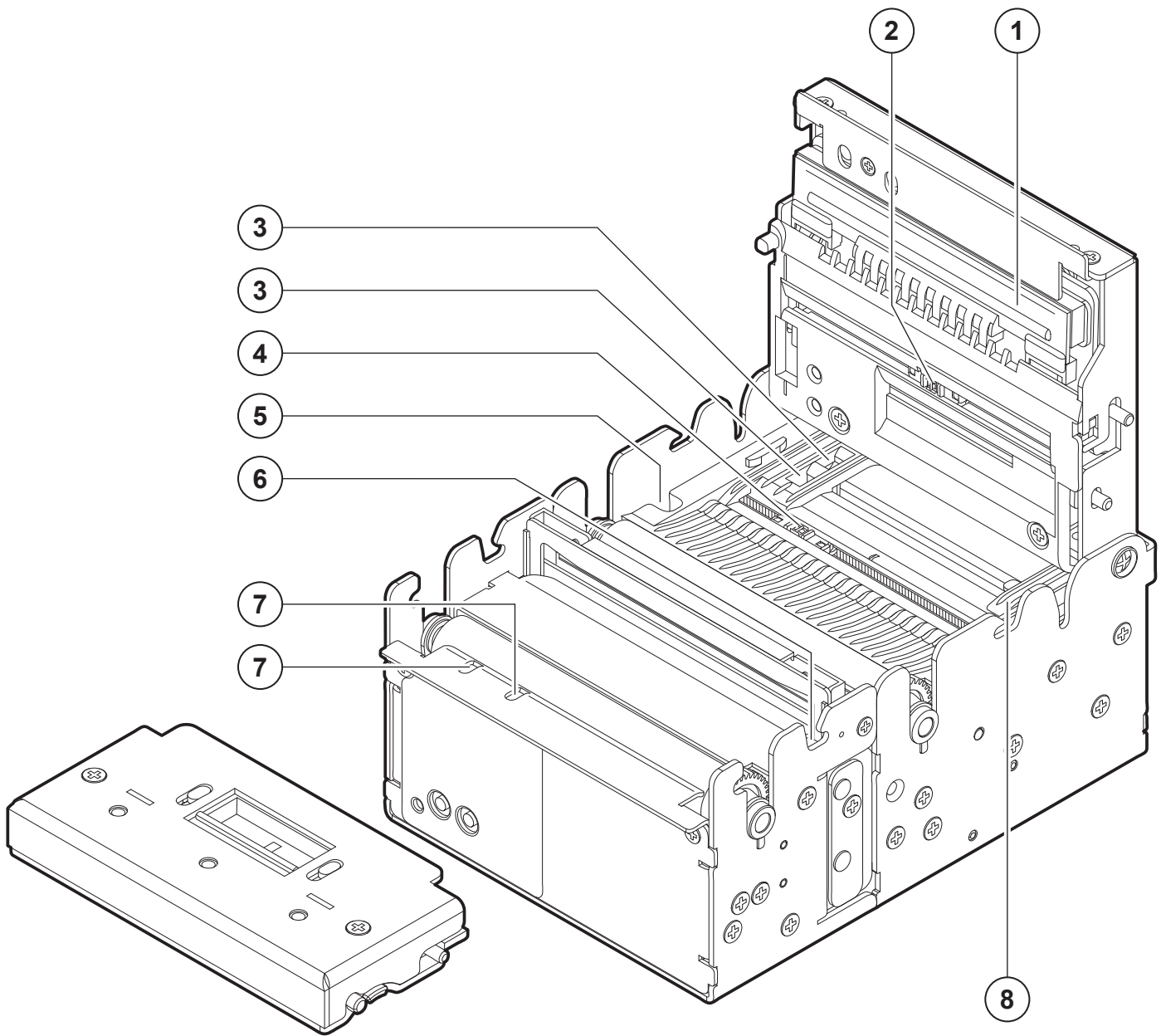



### 3.5 Device labels

The main data used to identify the machine are shown on the two labels attached to the upper cover or to the bottom of the device.

In particular, the product label shows the electrical data for the connection to a power source and the product code. The additional product label shows the serial number and the hardware revision (R).

product label

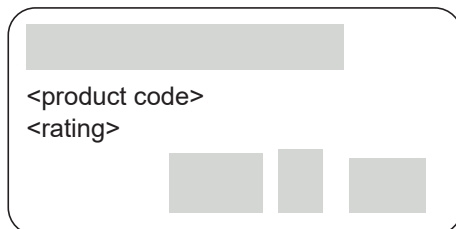

additional product label





### 3.6 Key functions: power up

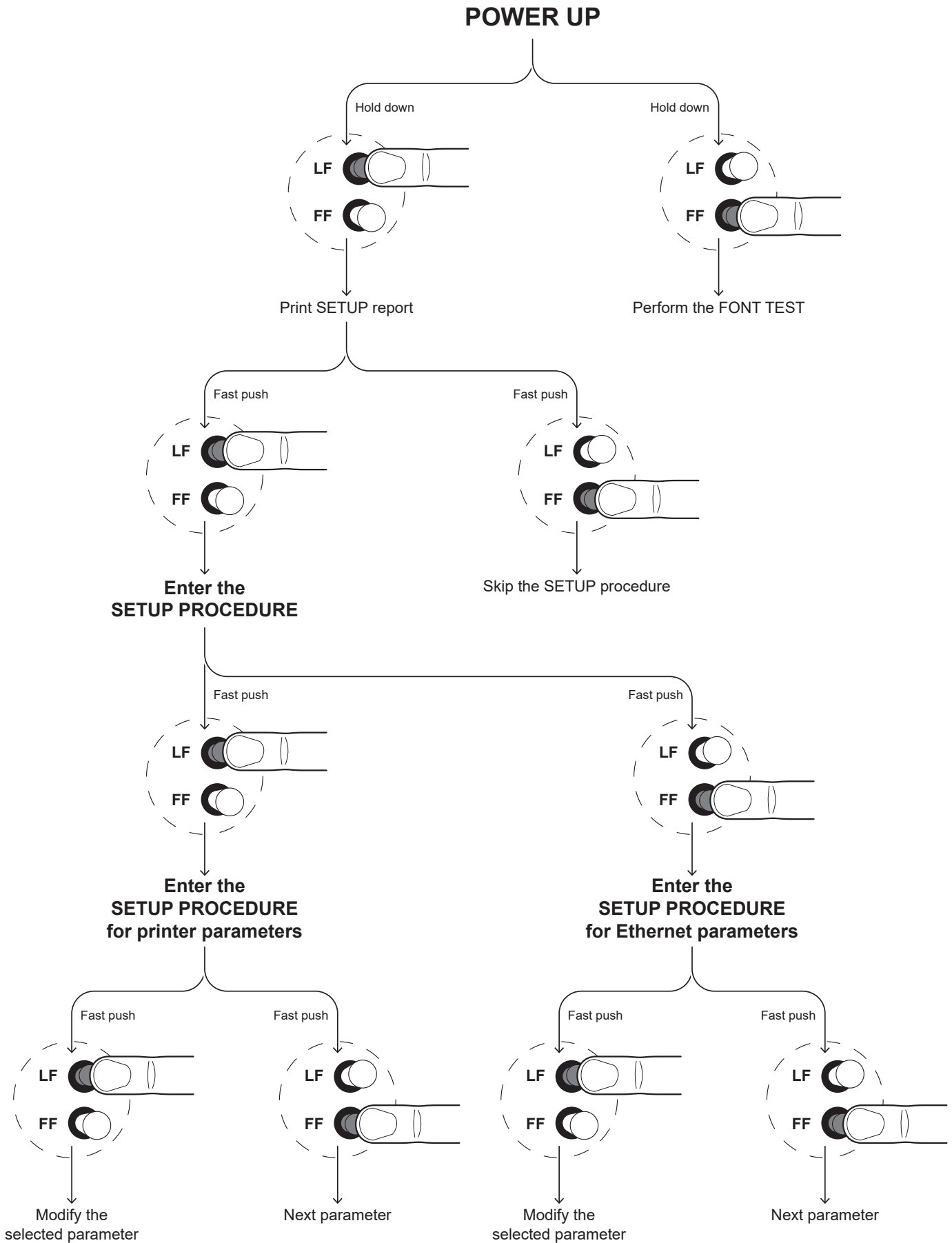

### 3.7 Key functions: standby

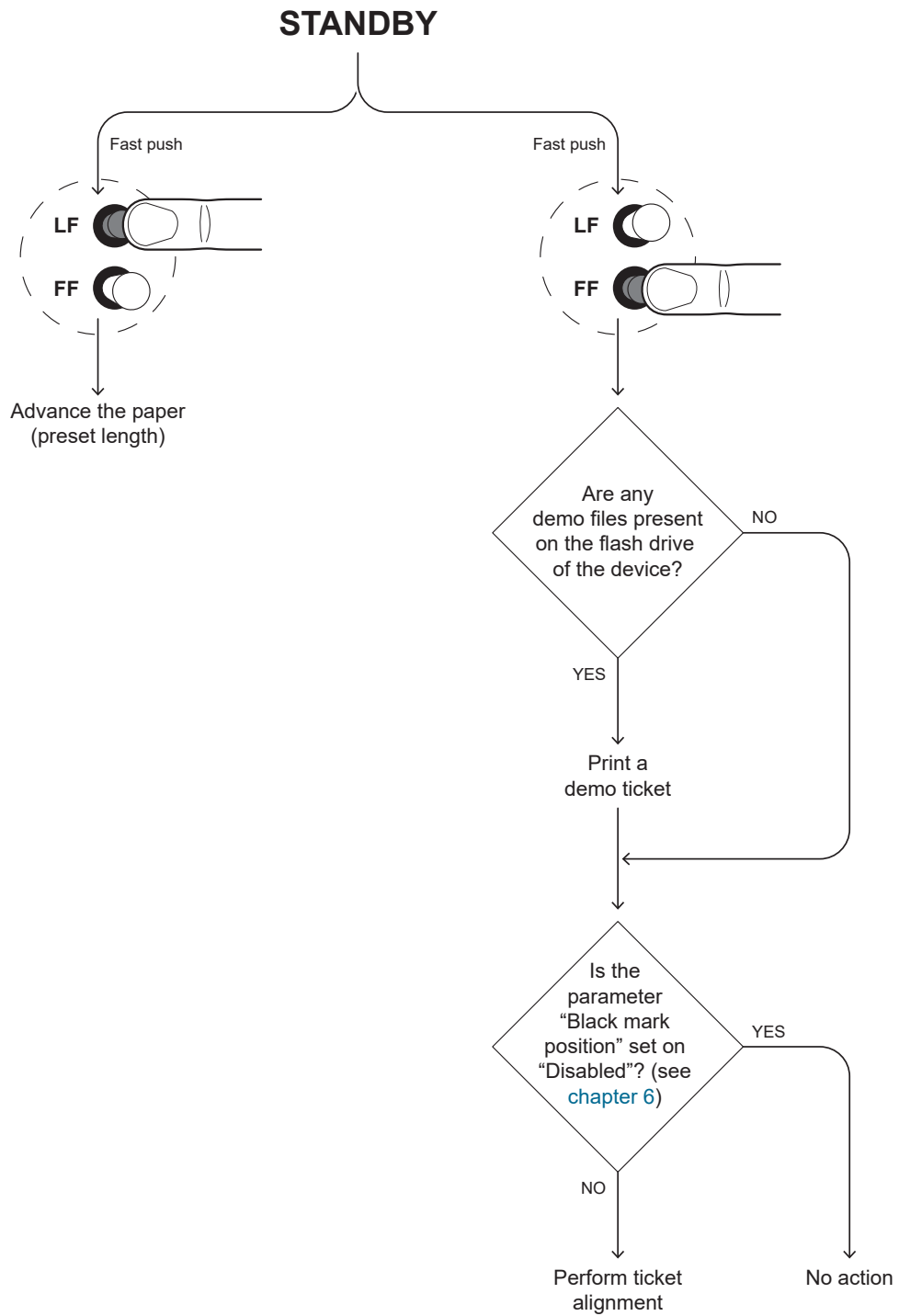



## 3.8 Status messages

The status LED indicates hardware status of device. Given in the table below are the various LED signals and the corresponding device status.

STATUS LED		DESCRIPTION
-	OFF	DEVICE OFF
GREEN	ON	DEVICE ON: NO ERROR
GREEN COMMUNICATION STATUS	x 1	RECEIVE DATA
	x 2	RECEPTION ERRORS (PARITY, FRAME ERROR, OVERRUN ERROR)
	x 3	COMMAND NOT RECOGNIZED
	x 4	COMMAND RECEPTION TIME OUT
YELLOW RECOVERABLE ERROR	x 2	PRINthead OVERHEATED
	x 3	PAPER END
	x 4	PAPER JAM
	x 5	POWER SUPPLY VOLTAGE INCORRECT
	x 6	COVER OPEN
RED UNRECOVERABLE ERROR	x 3	RAM ERROR
	x 4	EXTERNAL MEMORY ERROR
	x 5	AUTOCUTTER ERROR
	x 6	ERROR FOR PRINthead TYPE NOT RECOGNIZED



## 3.9 Display messages

TK180 MET 1, TK180 MET 2, TK180 MET 3  
TK180 CUT 1, TK180 CUT 2, TK180 CUT 3  
TK180 PLAS 1, TK180 PLAS 2, TK180 PLAS 3

---

PRINTER READY

Device on: no error

---

---

RECEIVING DATA

Receive data

---

---

RS232 RX ERROR

Reception errors  
(parity, frame error, overrun error)

---

---

COMMAND ERROR

Command not recognized

---

---

PRINTHEAD  
OVERTEMP

Heading over temperature

---

---

END PAPER

Paper end

---

---

PAPER JAM

Paper jam

---

---

POWER VOLTAGE ERROR

Power supply voltage incorrect

---

---

COVER OPEN

Cover open

---

---

RAM ERROR

RAM error

---

---

PRINTING DOCUMENT

Printing in progress

---

---

PRINT TICKET ERROR

Black mark alignment error

---



# 4 INSTALLATION

## 4.1 Fastening

### KPM180H 1

The device is provided with four fixing holes on the bottom of device (see following figure, dimensions in millimetres). To fasten the device on a panel, use four M3 screws.

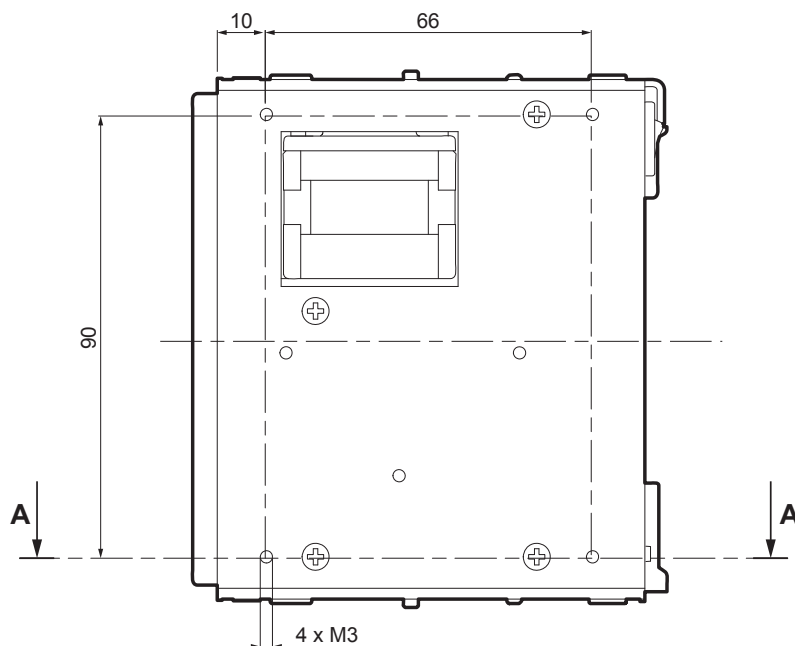

It's very important to consider the screws length not to damage the internal components placed near the fixing holes (see following figure, dimensions in millimetres).

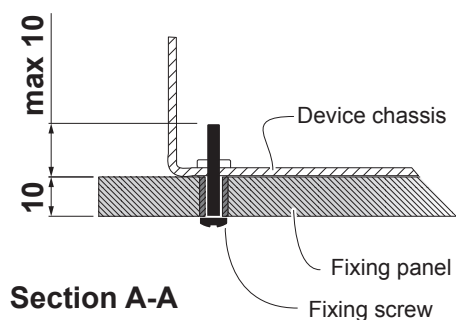

The screw length (L) will be calculated according to the thickness of the panel (Sp) on which the device is fixed, as follows:

$$L \leq 10 \text{ mm} + Sp$$

For example, if panel thickness is 10 mm (Sp = 10 mm), the maximum length for screws will be 20 mm.

**ATTENTION:** Correctly prepare the fixing holes for screws and the drilling for the paper mouth in order to avoid deformation and torsion of the device or its components which could compromise its operation.



## **KPM180H 2, KPM180H 3, KPM180H 4, KPM180H 5, KPM180H 6**

The device is provided with six fixing holes on the bottom of device (see following figure, dimensions in millimetres). To fasten the device on a panel, use six M3 screws.

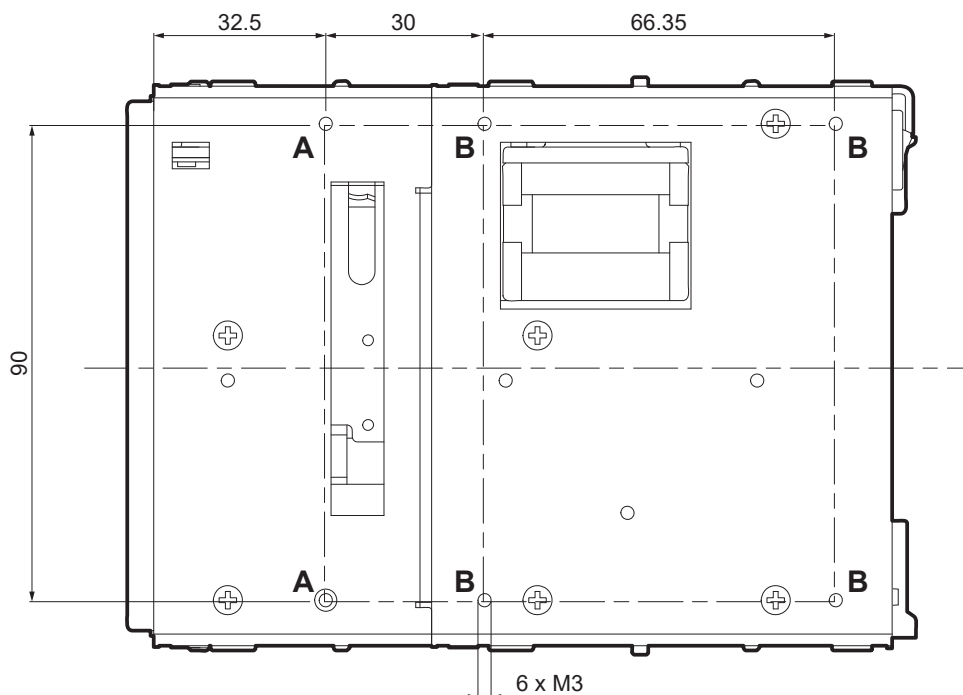

Additionally, the panel must provide an opening for dust of paper that meets the following measures (in millimetres):

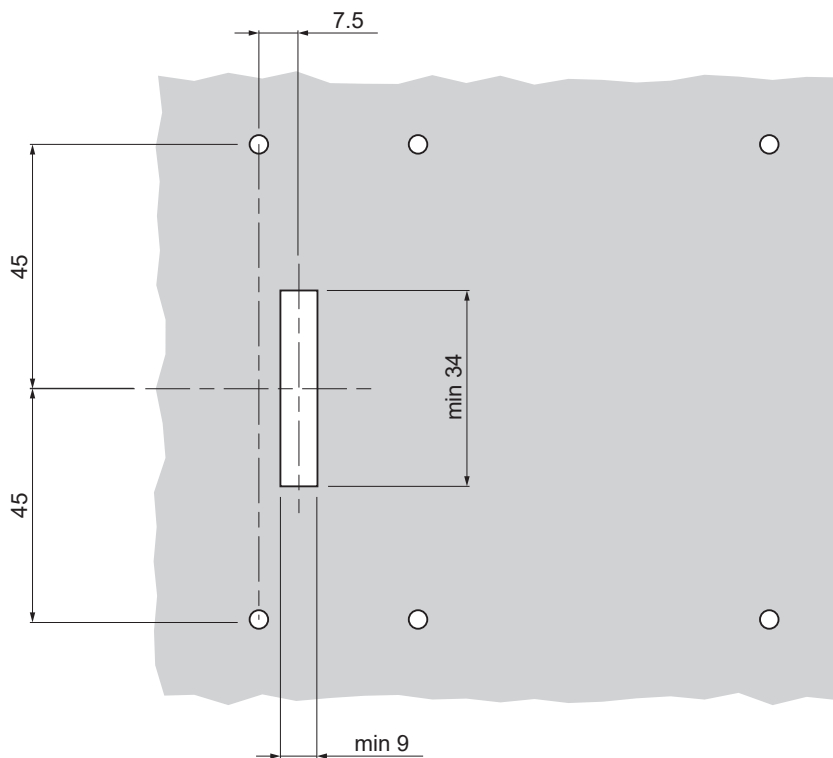

**ATTENTION:** Correctly prepare the fixing holes for screws and the drilling for the paper mouth in order to avoid deformation and torsion of the device or its components which could compromise its operation.





It's very important to consider the screws length not to damage the internal components placed near the fixing holes (see following figure, dimensions in millimetres).

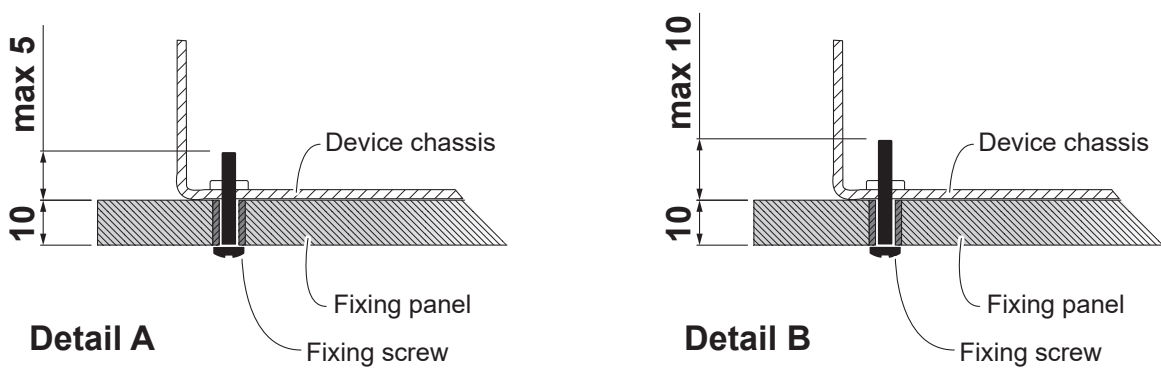

The screw length (L) will be calculated according to the thickness of the panel (Sp) on which the device is fixed, as follows:

$$L \leq 5 \text{ mm} + Sp \text{ (Detail A)}$$

$$L \leq 10 \text{ mm} + Sp \text{ (Detail B)}$$

For example, if panel thickness is 10 mm (Sp = 10 mm), The maximum screw length will be 15 mm (detail A) or 20 mm (detail B).

In presence of a front panel, consider a distance of at least 2 mm between the front panel and the cover of the presenter group (see following figure, dimensions in millimetres).

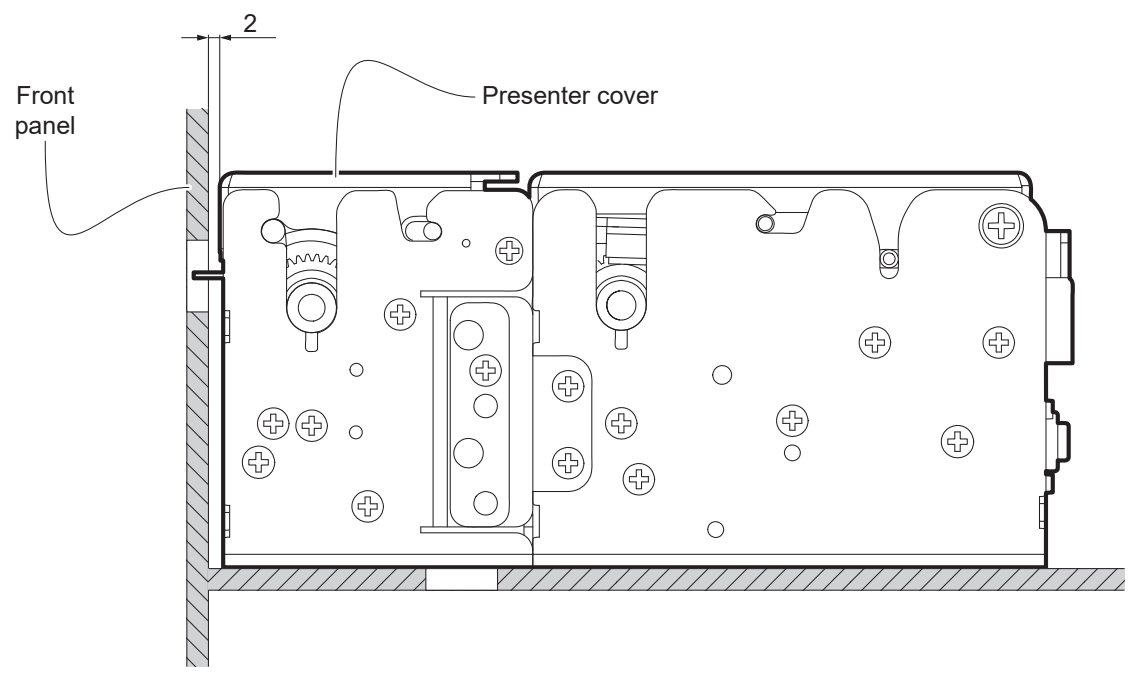



When you place the device in the operating position, make sure to leave the proper free space around the device of at least 20 mm, also considering the space for activating the mobile components (as the inspection door or the ejector group) so to not compromise operation and maintenance.

Refer to [paragraph 9.3](#) for models dimensions.

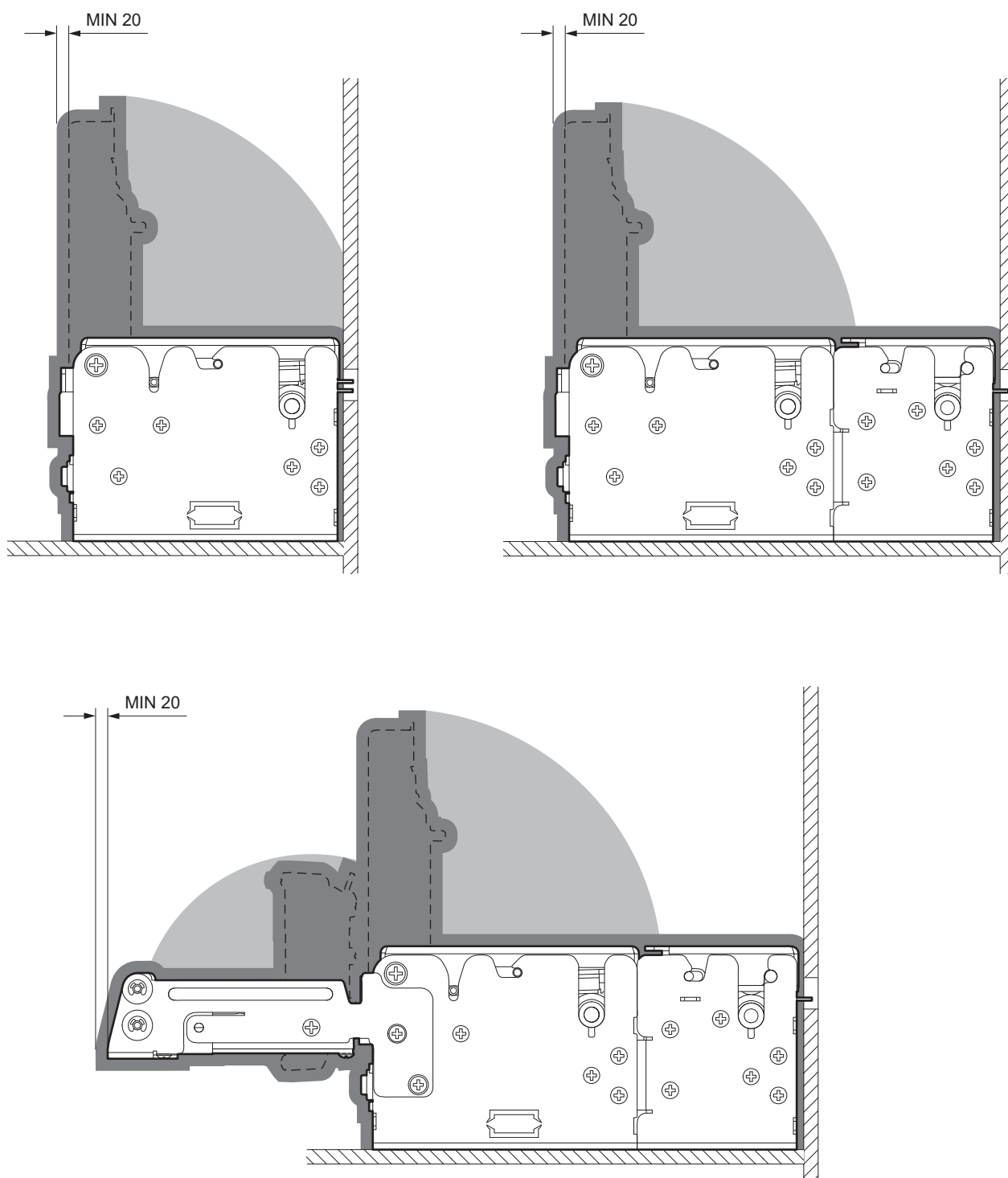



### **TK180 PLAS 1. TK180 PLAS 2. TK180 PLAS 3**

The device is provided with two slots placed at the bottom, for the mounting of the machine on a panel (see following figure, dimensions in millimetres).

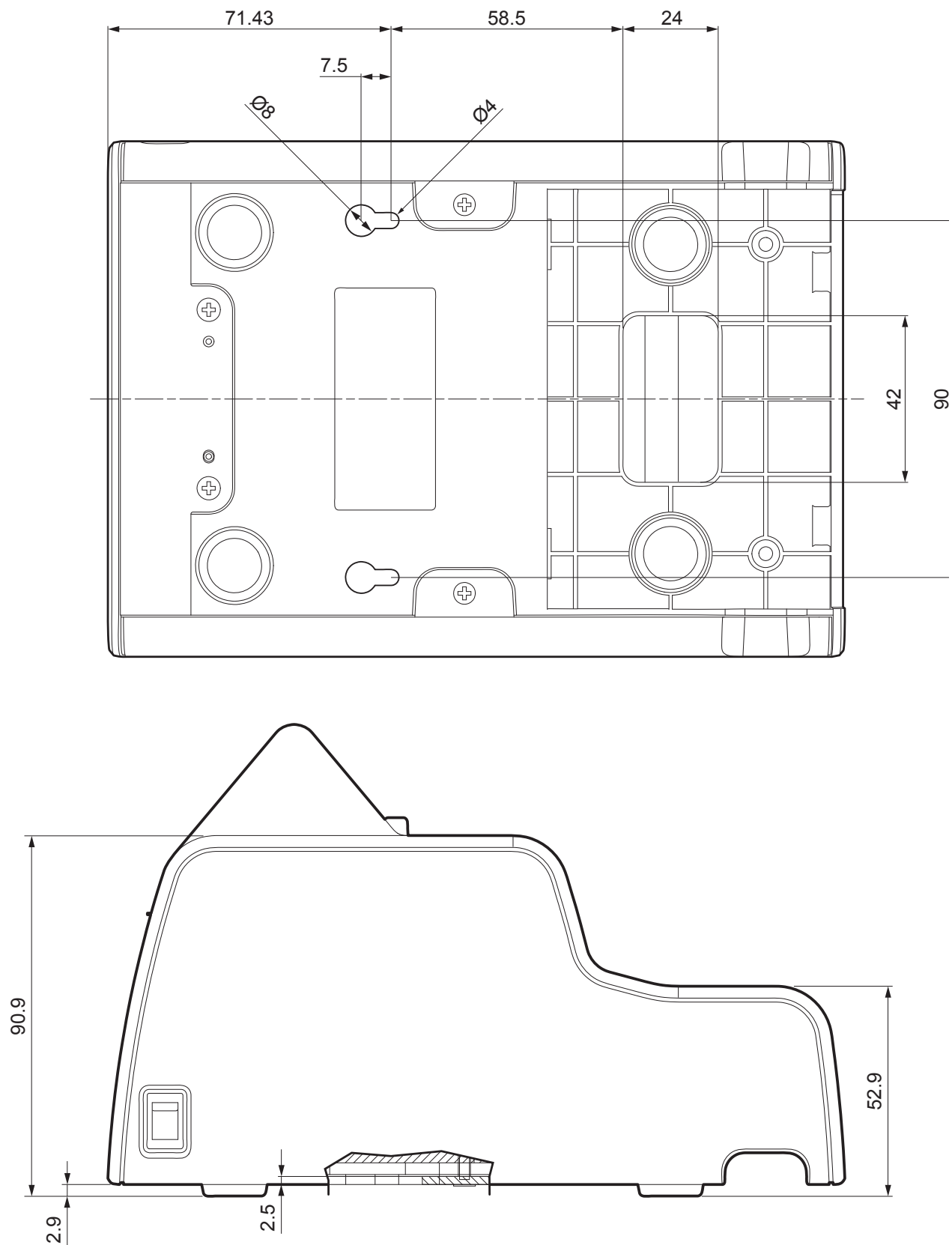



Additionally, the panel can provide an opening for the passage of the connection cables that meets the hole at the bottom of the device and two pins for a further fixing to the panel.

The measures (in millimeters) of the opening and the fixing pins are shown in the following figures.

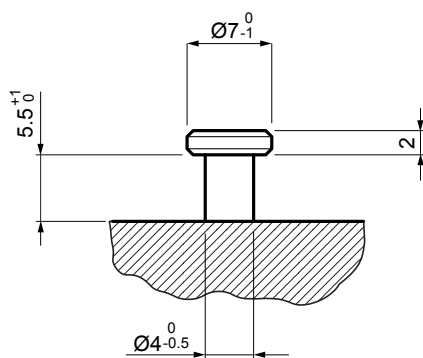
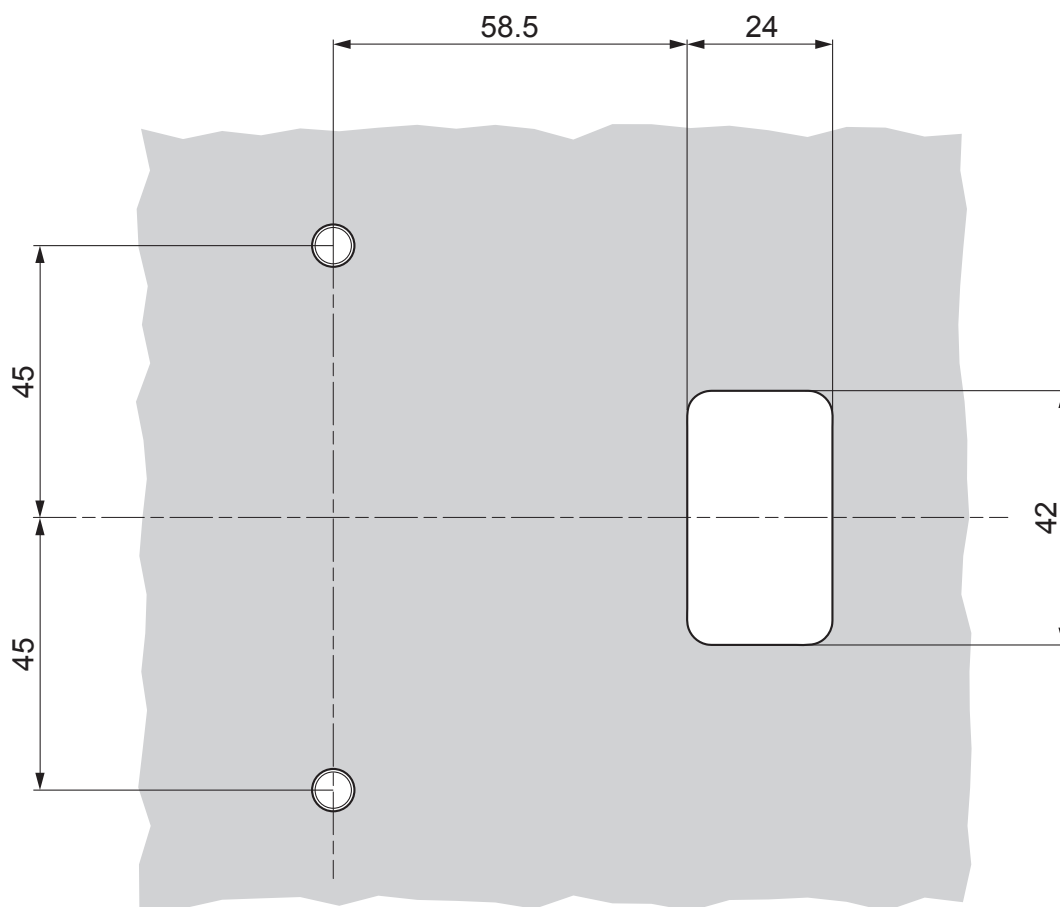



## 4.2 Low paper sensor

KPM180H 1, KPM180H 2, KPM180H 3  
KPM180H 4, KPM180H 5, KPM180H 6

The device includes a low paper sensor with the cable (see following figure). To fix the sensor, use an M3 screw not supplied.

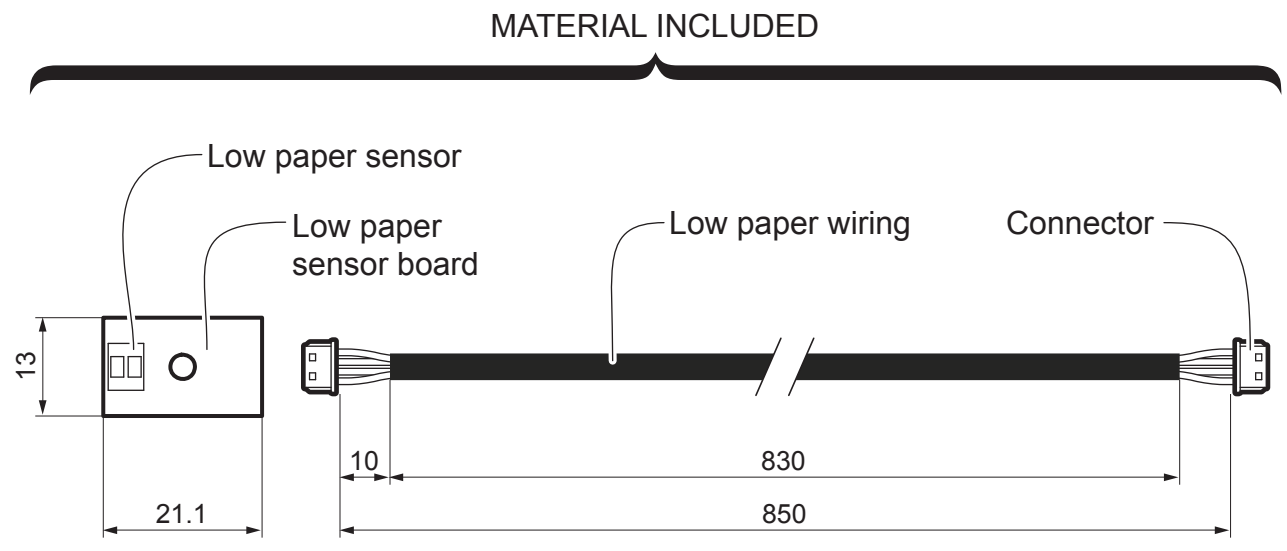

MATERIAL NOT INCLUDED



Fixing screw M3

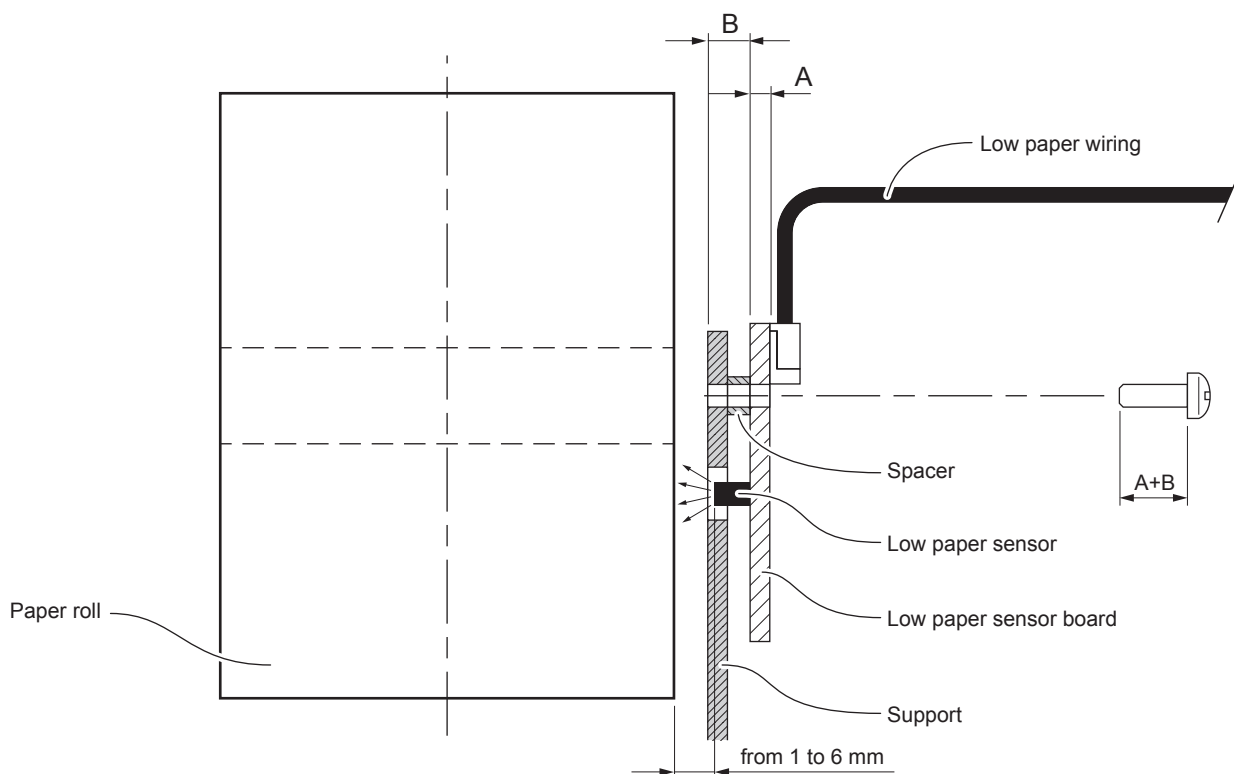

For the assembly procedure, proceed as follows:

**1**

Fix the low paper sensor board to the support by using an M3 screw not included.  
For the correct functioning of the low paper sensor, comply with the measures specified.

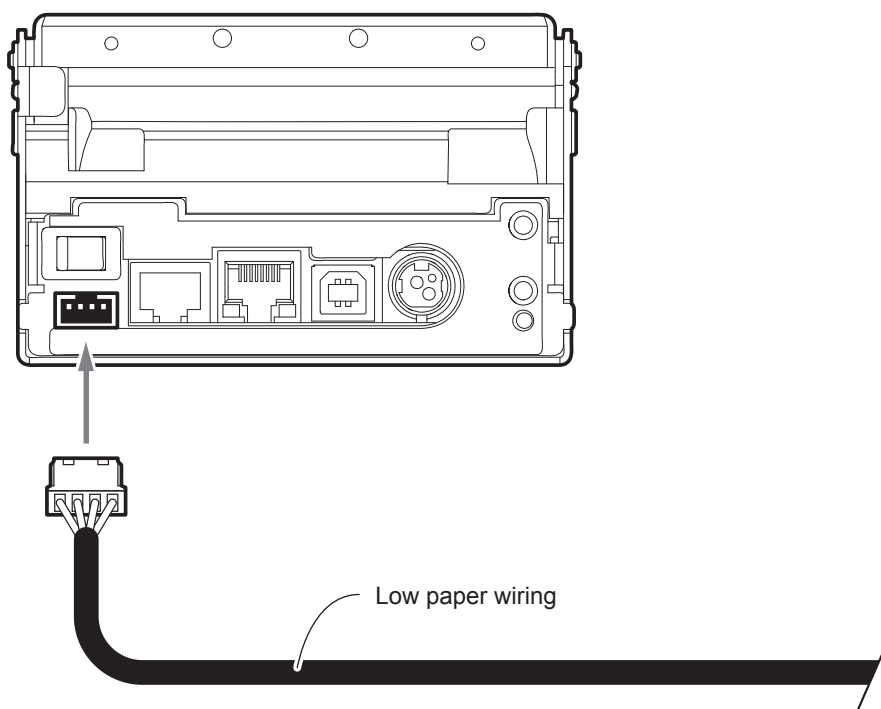
**2**

Connect the wiring coming from the low paper sensor board  
at the connector shown in figure.

## 4.3 Connections

The following figure shows the possible connections for the device. When the RS232 and USB communication cables are connected to the printer at the same time, communication takes place via the USB port.

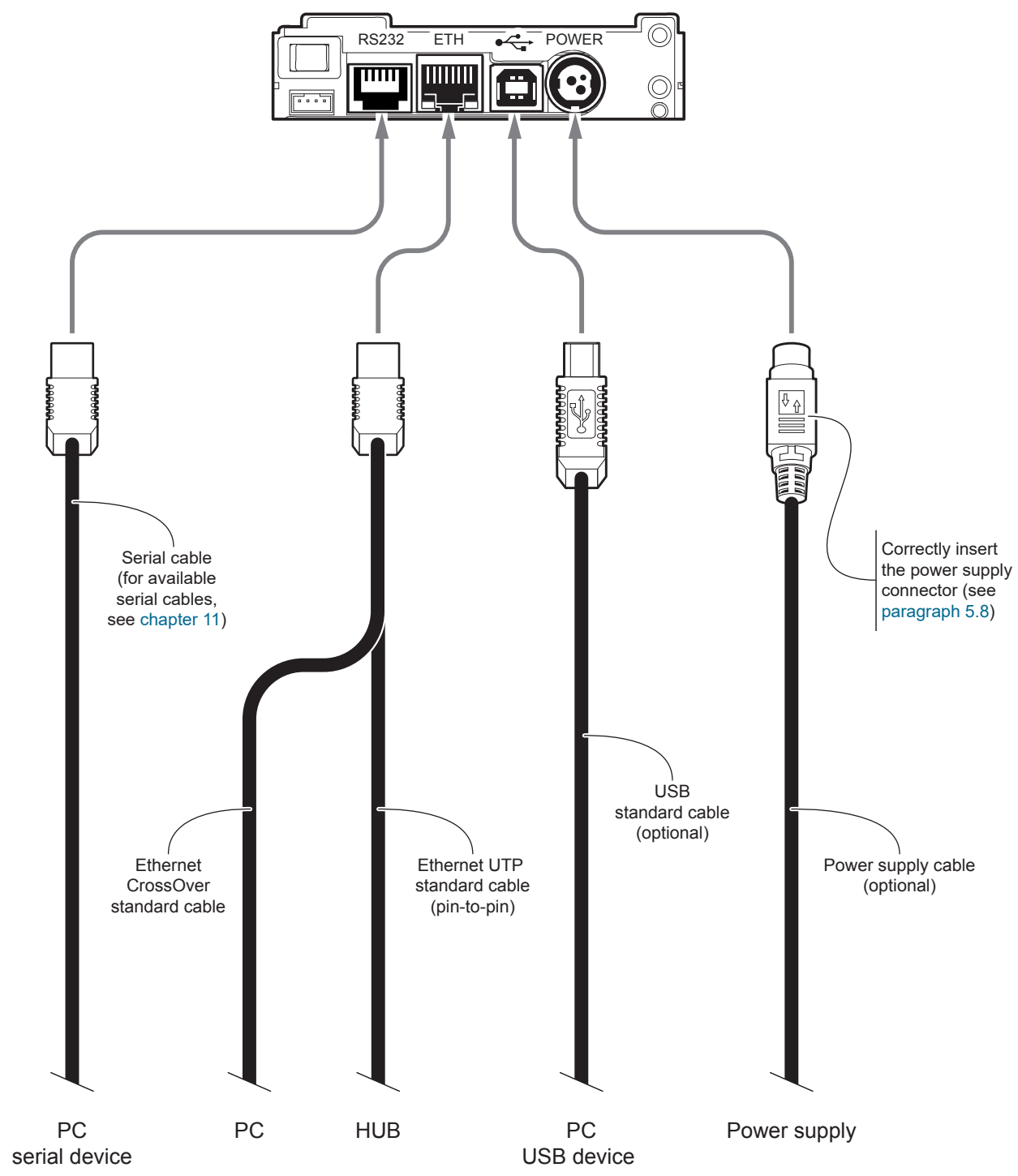

**ATTENTION:** In some conditions, we recommend the installation of a ferrite core on the power supply cable.

## 4.4 Pinout



**POWER SUPPLY**  
Tripolar female connector

J20	1	GND
	2	+24 Vdc
	3	GND
	4	Frame GND

The following figure shows the connector pinout of the power supply cable for the device:

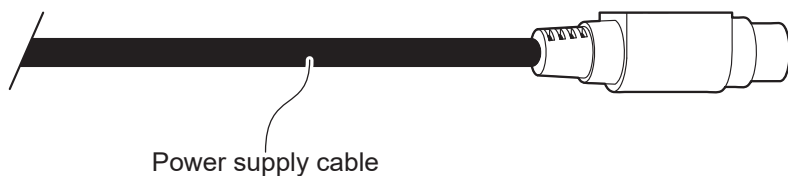

Tripolar male connector

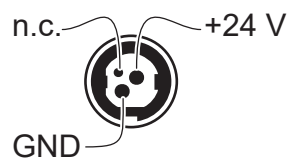

**ATTENTION:**  
Respect power supply polarity.

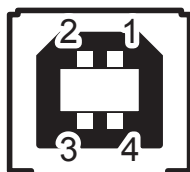

**USB INTERFACE**  
Female USB type B connector

J2	1	USB0-VBUS (in)
	2	USB0_D- (in/out)
	3	USB0_D+ (in/out)
	4	GND
	SH1	SHIELD
	SH2	SHIELD



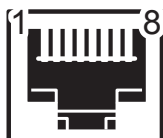

# RS232 SERIAL INTERFACE

Female RJ45 connector

J1	1	DT	(in)	When +VRS232, device is power on
	2	TX	(out)	During transmission, takes the values -VRS232 and +VRS232 depending on data
	3	RX	(in)	During reception, takes the values -VRS232 and +VRS232 depending on data
	4	DS		
	5	GND		
	6	DT	(in)	When +VRS232, device is power on
	7	CT		
	8	RT	(out)	When +VRS232, device is ready to receive data

Given the presence of the RS232 standard, logic value "0" corresponds to the voltage value +VRS232 (voltage value between +3 Vdc and +15 Vdc) and logic value "1" corresponds to the voltage value -VRS232 (voltage value between -3 Vdc and -15 Vdc).

### DEVICE > PC connection

The following picture shows an example of connection between the device and a personal computer using an 8 pin RJ45 male and a 9 pin RS232 serial connector:

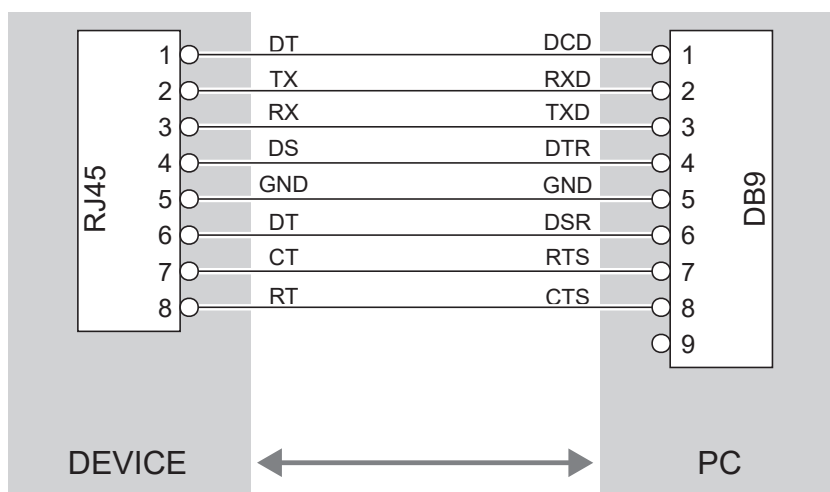

When use a serial cable, we recommend the installation of a ferrite core at the end of the same cable.

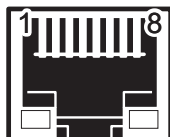

## ETHERNET INTERFACE

Female RJ45 connector

J23	1	RX +1
	2	+3.3V ETH
	3	RX -1
	4	TX +1
	5	+3.3V ETH
	6	TX -1
	7	n.c
	8	GND
	9	+3.3 V
	10	LED-LNK
	11	+3.3 V
	12	LED-LAN
	13	Shield
	14	Shield

The functionality of two LED are specified in the following tables:

- For 10Base-T connection:

LED	FUNCTION
LED-LNK	Link (yellow color): the LED lights up when a connection is active
LED-LAN	Rx/Tx: (green color): the LED lights up when occurs a data reception or transmission

- For 10/100Base-TX connection:

LED	FUNCTION
LED-LNK	The LED light (yellow color) on when a connection is active and flashes when occurs a data reception or transmission
LED-LAN	The LED light (green color) on when occurs a 100 Mbit connection and off when occurs a 10 Mbit connection

The device automatically recognizes the type of connection (cross or pin-to-pin).

The pinout shown in table represents the input signals to component J23 before the isolation voltage transformer (through-hole pin).



## 4.5 Driver and SDK

The drivers for the following operating system are available in the website [www.custom4u.it](http://www.custom4u.it).

OPERATING SYSTEM	DESCRIPTION	INSTALLATION PROCEDURE
Windows	Driver for Windows XP	<p>From the Start menu, press Run and type-in the path where the SW was saved on your PC, then click OK. Follow the instructions that appear on the screen to install the driver.</p>
	Driver for Windows VISTA (32/64 bit)	
	Driver for Windows 7 (32/64 bit)	
	Driver for Windows 8 (32/64 bit)	
	Driver for Windows 8.1 (32/64 bit)	
	Driver for Windows 10 (32/64 bit)	
	Self-installing driver for Virtual COM (32/64 bit) (see <a href="#">paragraph 6.6</a> )	
Driver for OPOS		
Linux	(32/64 bit)	Follow the instruction get back on the "Readme.txt" file. You can find it in the software package downloaded in advance.
Android	SDK for CustomAndroidAPI	Extract the zipped folder to the destination path desired. Follow the instructions present in the software package that you downloaded on how to install and use the SDK.
iOS	SDK for CustomiOSApi	Extract the zipped folder to the destination path desired. Follow the instructions present in the software package that you downloaded on how to install and use the SDK.



# 5 OPERATION

## 5.1 Opening device cover

KPM180H 1, KPM180H 2, KPM180H 3  
KPM180H 4, KPM180H 5, KPM180H 6

TK180 PLAS 1, TK180 PLAS 2  
TK180 PLAS 3

**1**

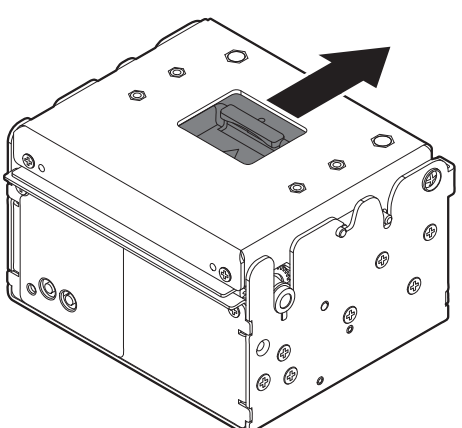

Push the opening lever in the direction shown in the figure.

**2**

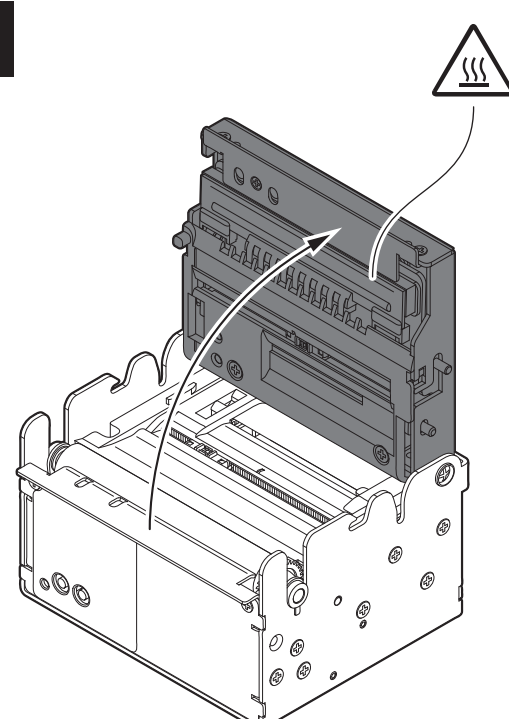

Open the device cover.

**1**

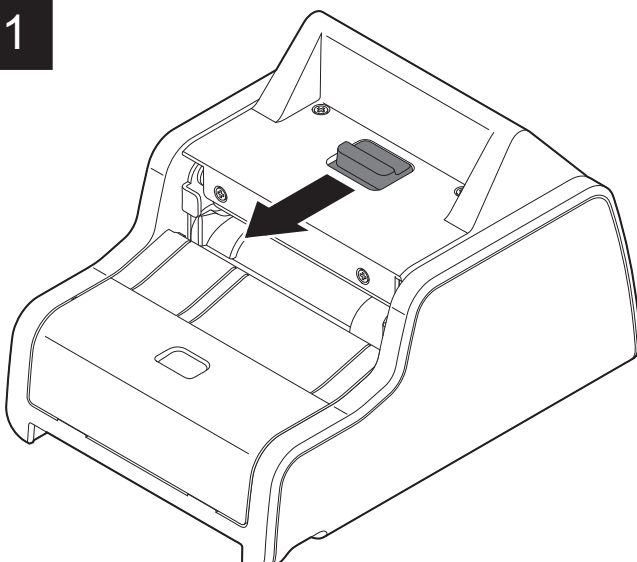

Push the opening lever in the direction shown in the figure.

**2**

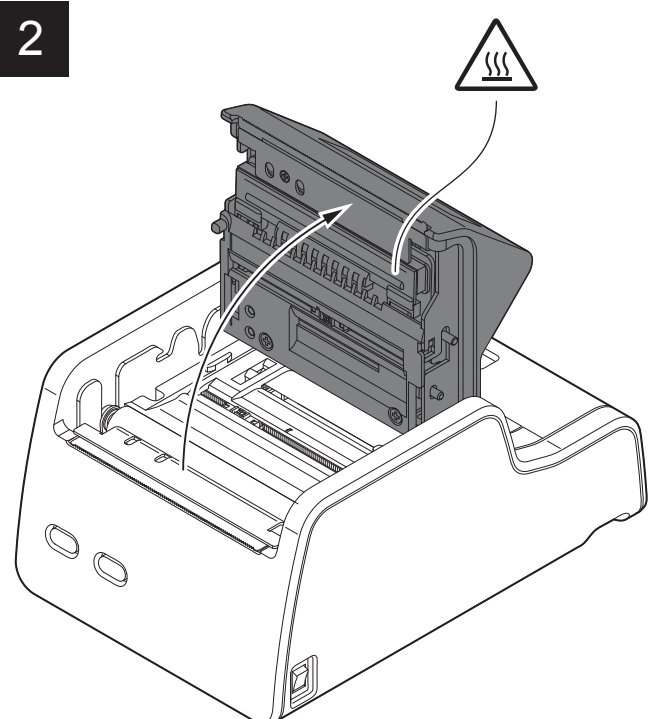

Open the device cover.



**TK180 MET 1, TK180 MET 2, TK180 MET 3**  
**TK180 CUT 1, TK180 CUT 2, TK180 CUT 3**

1

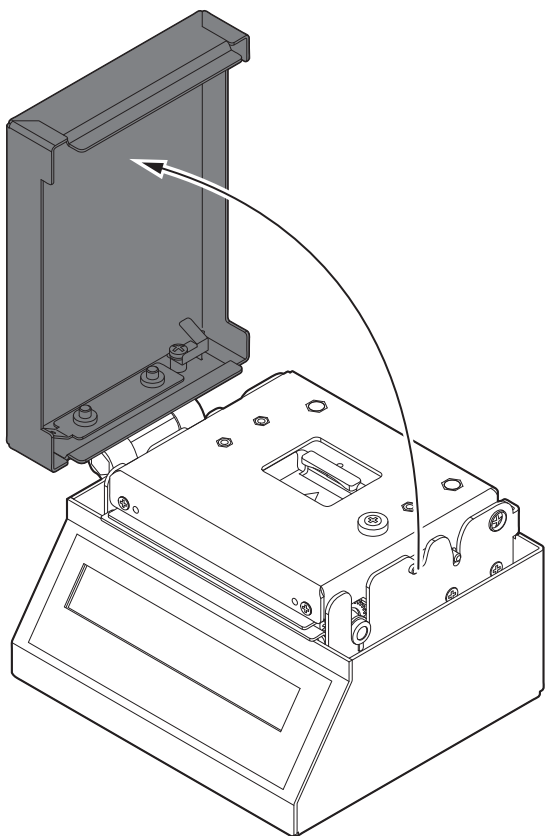

Open the metallic cover.

2

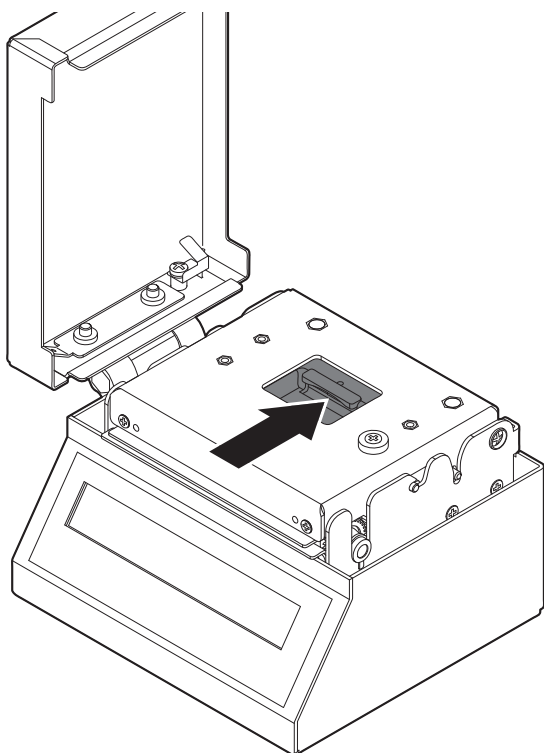

Push the opening lever shown in figure.

3

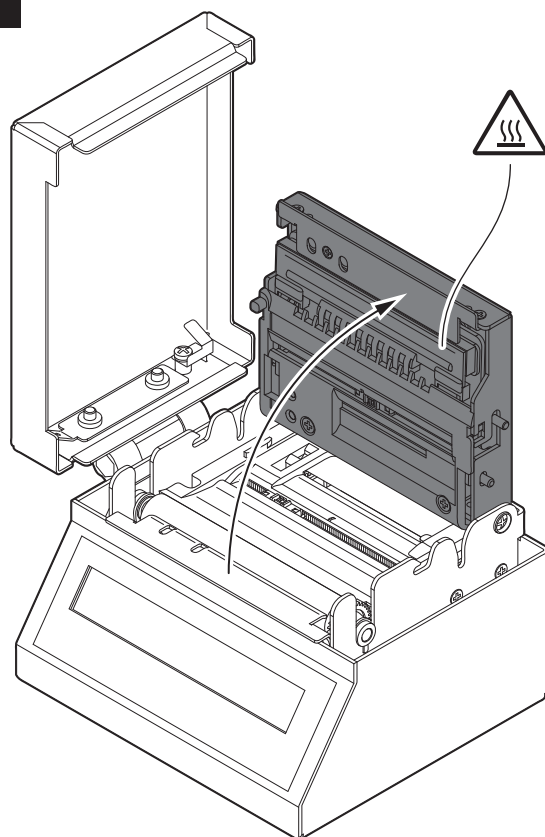

Open the device cover.

## 5.2 Adjusting device for 82.5 mm paper width

To manage paper width of 82.5 mm, move the adjustable cursor at the right end point as shown in the following figure (for some models, only the internal printer group is represented).

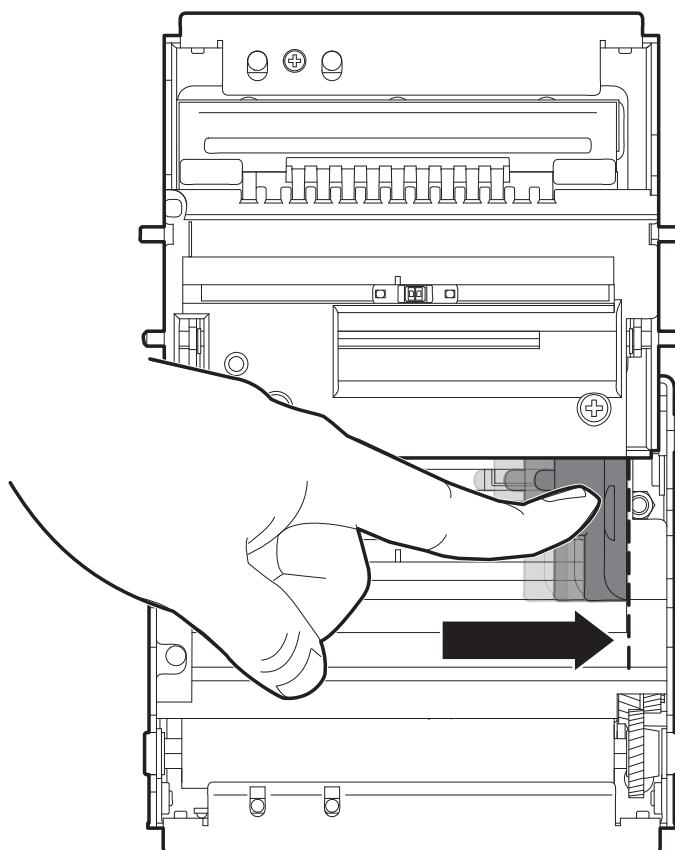

**TK180 MET 1, TK180 MET 2**  
**TK180 CUT 1, TK180 CUT 2, TK180 CUT 3**  
**TK180 PLAS 1, TK180 PLAS 2, TK180 PLAS 3**

If you use the device with the paper roll holder code 974HL010000009 or 974HL020000006, provided as an accessory (see [chapter 11](#)), adjust the two bushing on the roll holder pin by placing both the bushings on the external notches (position A) or on the internal notches (position B) as shown in figure.



## 5.3 Adjusting device for 80 mm paper width

**KPM180H 6**  
**TK180 CUT 3, TK180 MET 3**  
**TK180 PLAS 3**

To manage paper width of 80 mm, move the adjustable cursor at the left end point as shown in the following figure (for some models, only the internal printer group is represented).

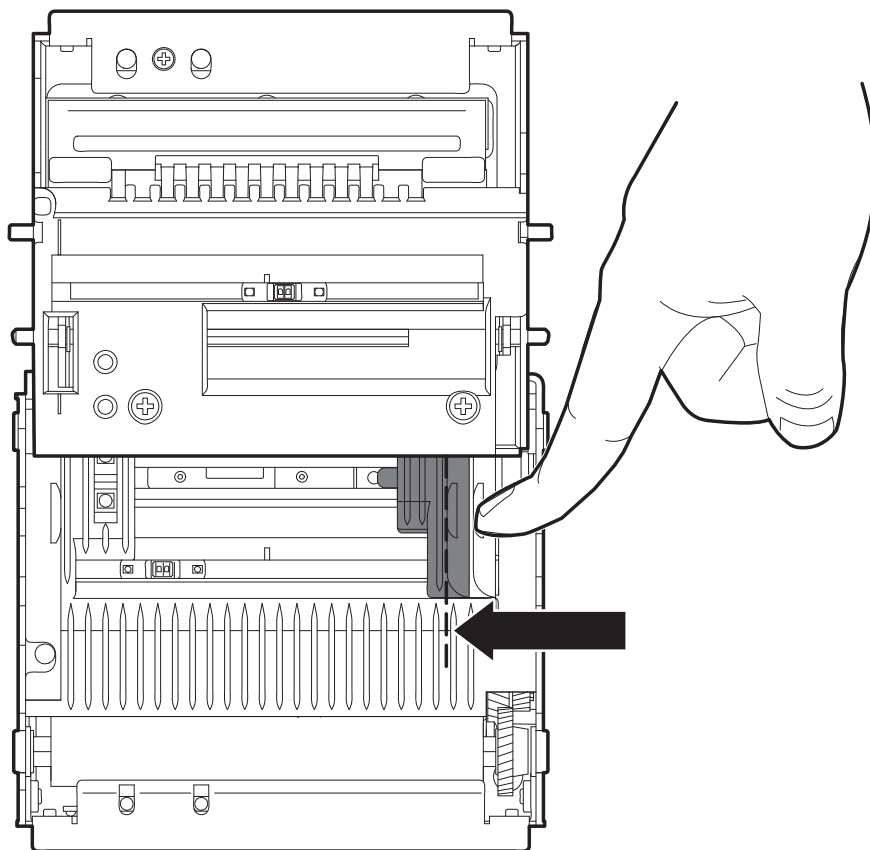



## 5.4 Adjusting device for 54 mm paper width

**KPM180H 6**  
**TK180 CUT 3, TK180 MET 3**  
**TK180 PLAS 3**

To manage paper width of 54 mm, it is necessary to assemble the paper block guide provided with the device (for some models, only the internal printer group is represented).

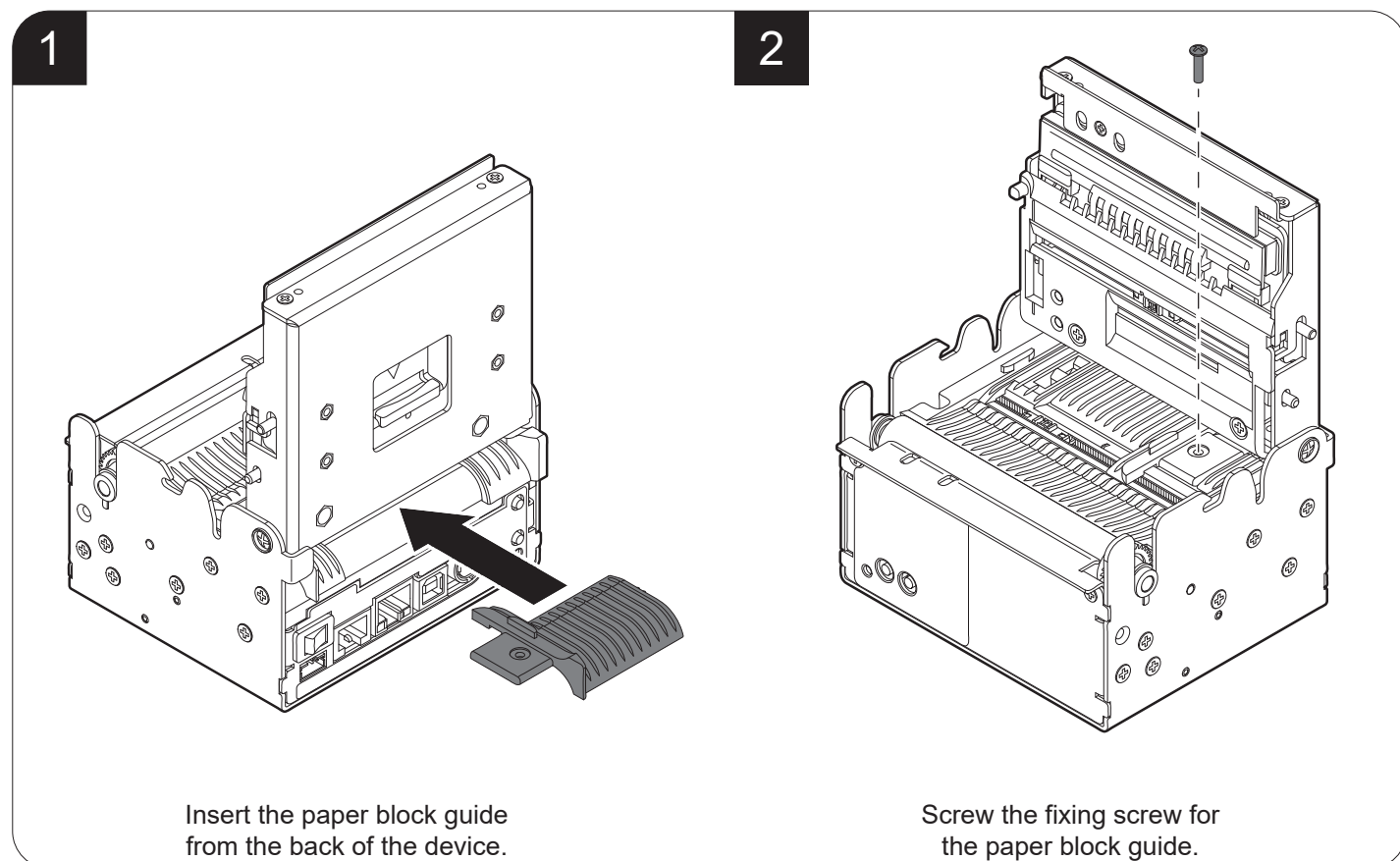

**KPM180H 1, KPM180H 2, KPM180H 3, KPM180H 4, KPM180H 5**  
**TK180 MET 1, TK180 MET 2**  
**TK180 CUT 1, TK180 CUT 2**  
**TK180 PLAS 1, TK180 PLAS 2**

To manage paper width of 54 mm, it is recommended to assemble the paper block guide shown in the following figure, provided with the device.

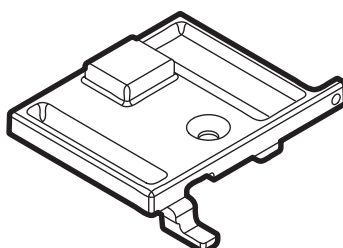



To assemble the paper block guide proceed as follows (for some models, only the internal printer group is represented).

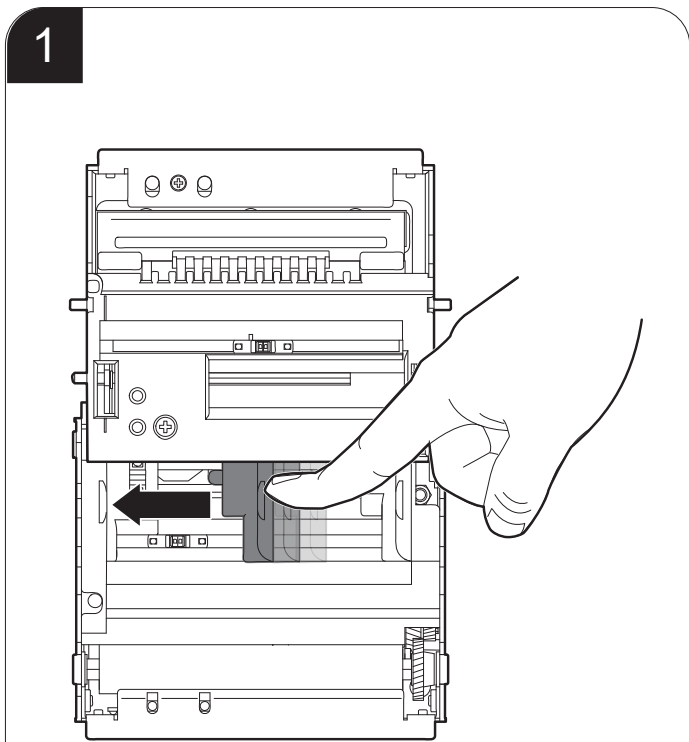

Move the adjustable cursor in the direction shown in the figure.

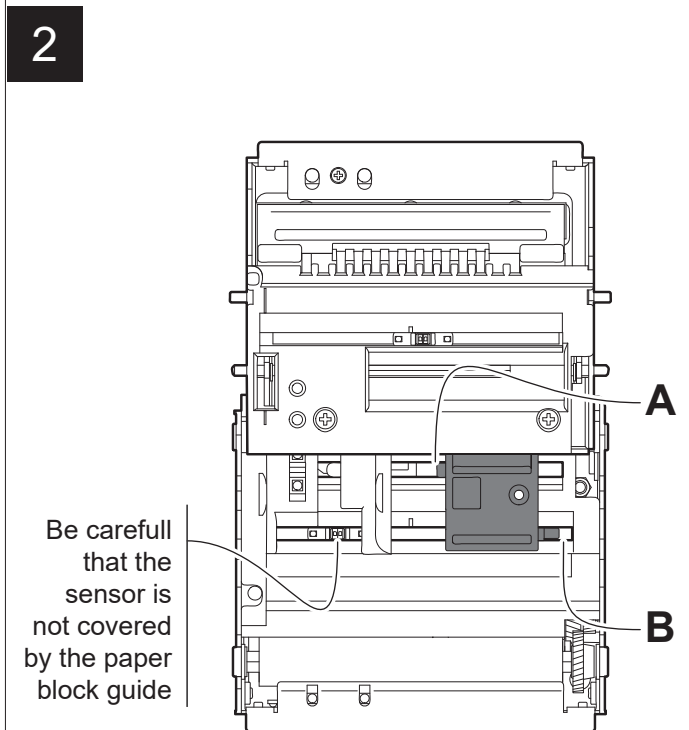

Assemble the paper block guide as shown in figure by inserting the two plastic pins into the tracks A and B.

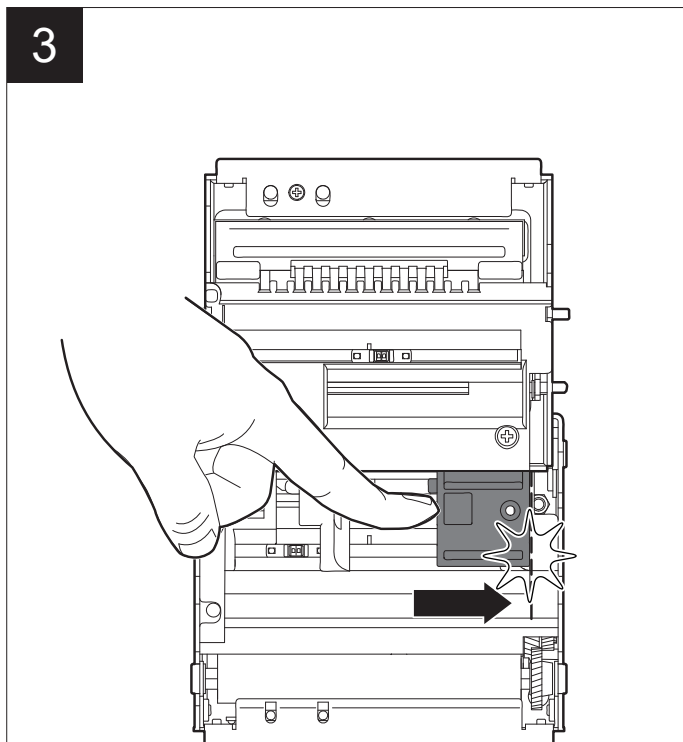

Move the paper block guide to the end point against the right edge of the track B.

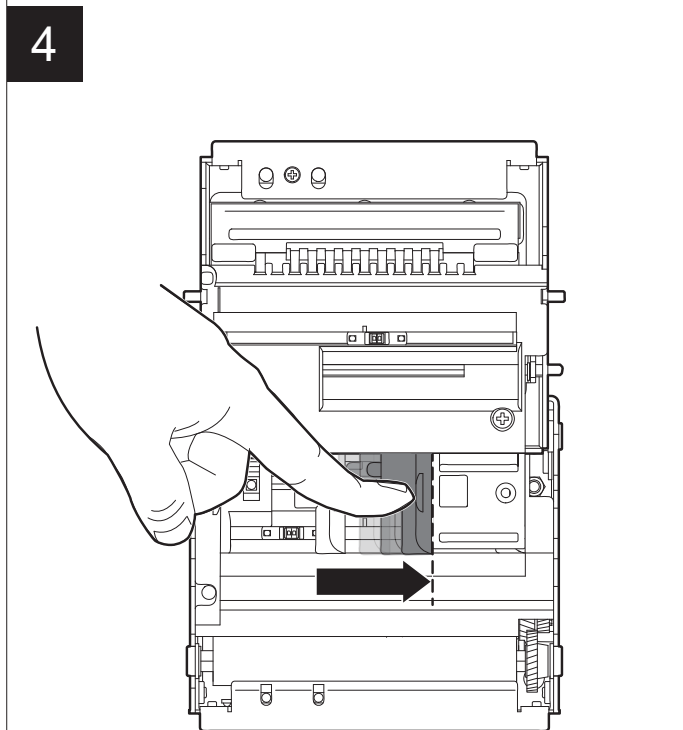

Move the adjustable cursor to the end point against the left edge of the paper block guide.

**TK180 MET 1, TK180 MET 2**  
**TK180 CUT 1, TK180 CUT 2, TK180 CUT 3**  
**TK180 PLAS 1, TK180 PLAS 2, TK180 PLAS 3**

If you use the device with the paper roll holder code 974HL010000009 or 974HL020000006, provided as an accessory (see [chapter 11](#)), adjust the two bushing on the roll holder pin by placing the bushings on the two adjacent notches located on the same side of the mobile paper guide of the device, according to the assembling side of the frame (right or left).

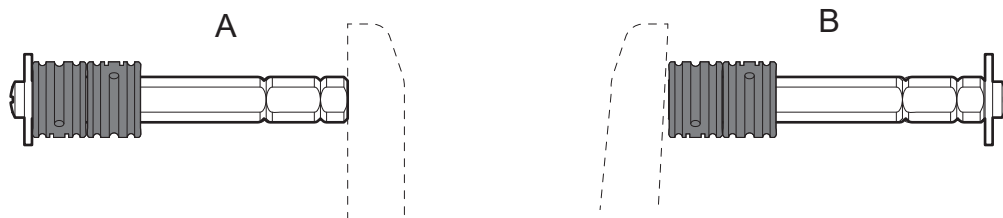

## 5.5 Adjusting device for 20 mm to 25 mm paper width

KPM180H 1, KPM180H 2, KPM180H 3, KPM180H 4, KPM180H 5

TK180 MET 1, TK180 MET 2

TK180 CUT 1, TK180 CUT 2

TK180 PLAS 1, TK180 PLAS 2

To manage paper width from 20 mm to 25 mm, it is necessary to assemble the reducer shown in the following figure, provided with the device.

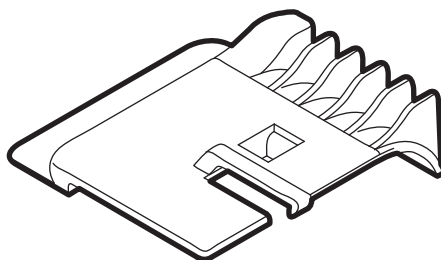

Assemble the reducer as shown in the following figure (for some models, only the internal printer group is represented).

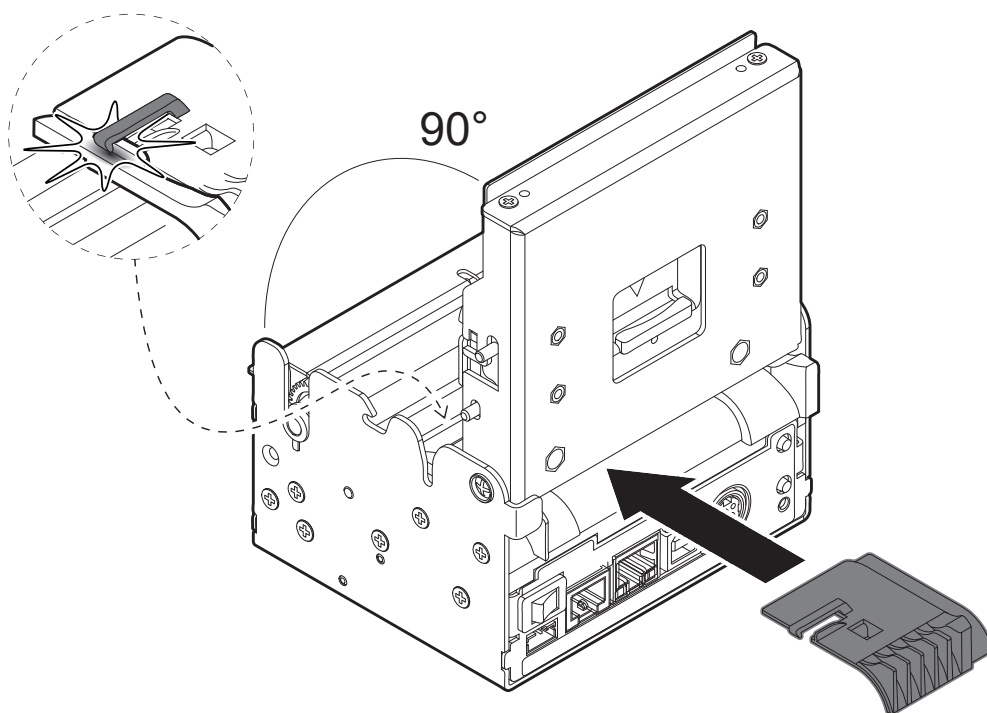

## 5.6 Adjusting device for other paper width

KPM180H 1, KPM180H 2, KPM180H 3, KPM180H 4, KPM180H 5

TK180 MET 1, TK180 MET 2

TK180 CUT 1, TK180 CUT 2

TK180 PLAS 1, TK180 PLAS 2

To manage a paper width with values different from the previous ones, simply adjust the position of the adjustable cursor according to the paper to use (for some models, only the internal printer group is represented).

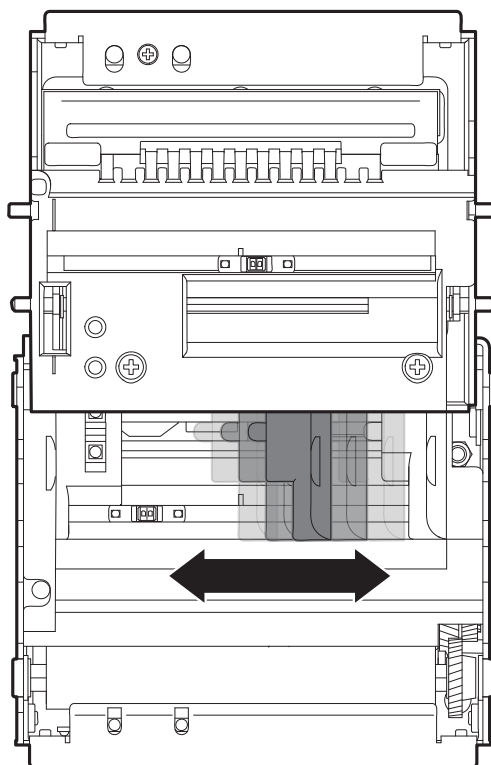

## 5.7 Adjusting the alignment sensors

The device is equipped with two mobile sensors for the detection of the alignment black mark placed both on the thermal side and on the non-thermal side of paper as shown in the following figure (for some models, only the internal printer group is represented).

The user can manually move these mobile sensors according to the position and the type of the black mark printed on paper (see [chapter 7](#)).

To use these sensors, the “Black mark position” setup parameter must be correctly set (see [chapter 6](#)).

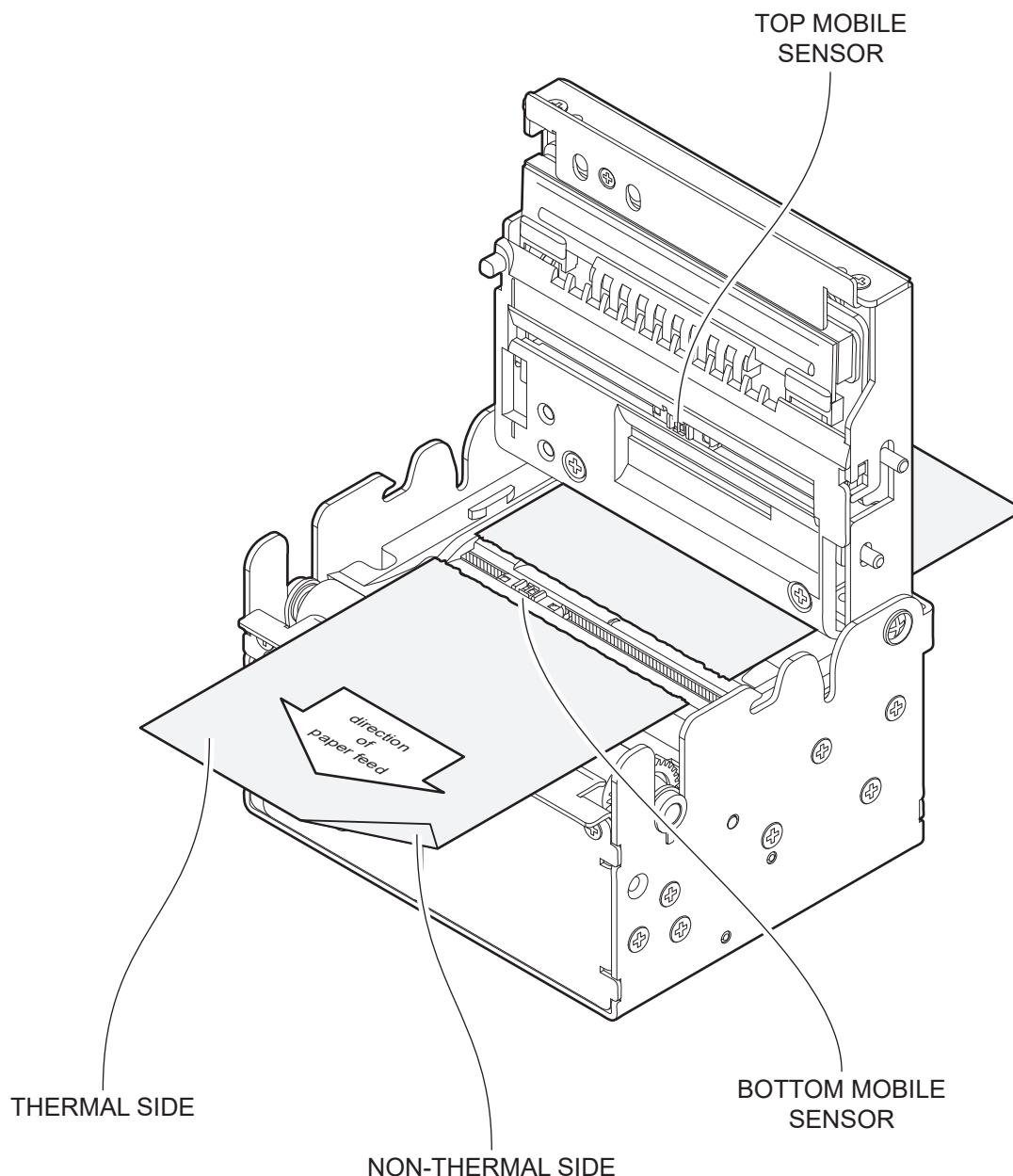

To adjust the mobile sensors position according to the position and type of black mark, open the device cover (see [paragraph 5.1](#)) and move the sensors to the desired position using a small screwdriver or a pointed object.

On both the flat there is a reference notch to facilitate the adjustment of the mobile sensors in the central position (see following image).

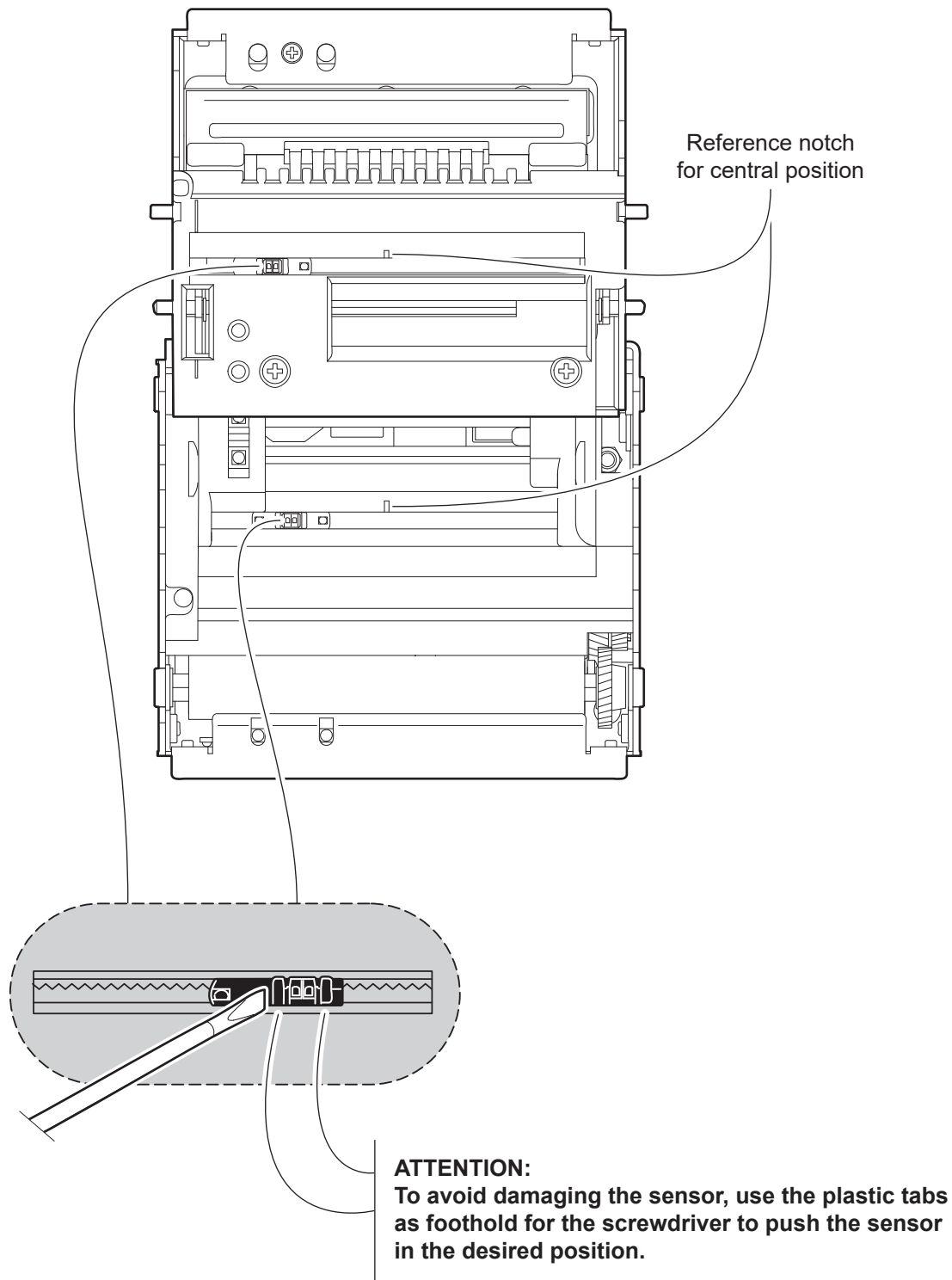

## 5.8 Switch the device on

KPM180H 1, KPM180H 2, KPM180H 3  
KPM180H 4, KPM180H 5, KPM180H 6

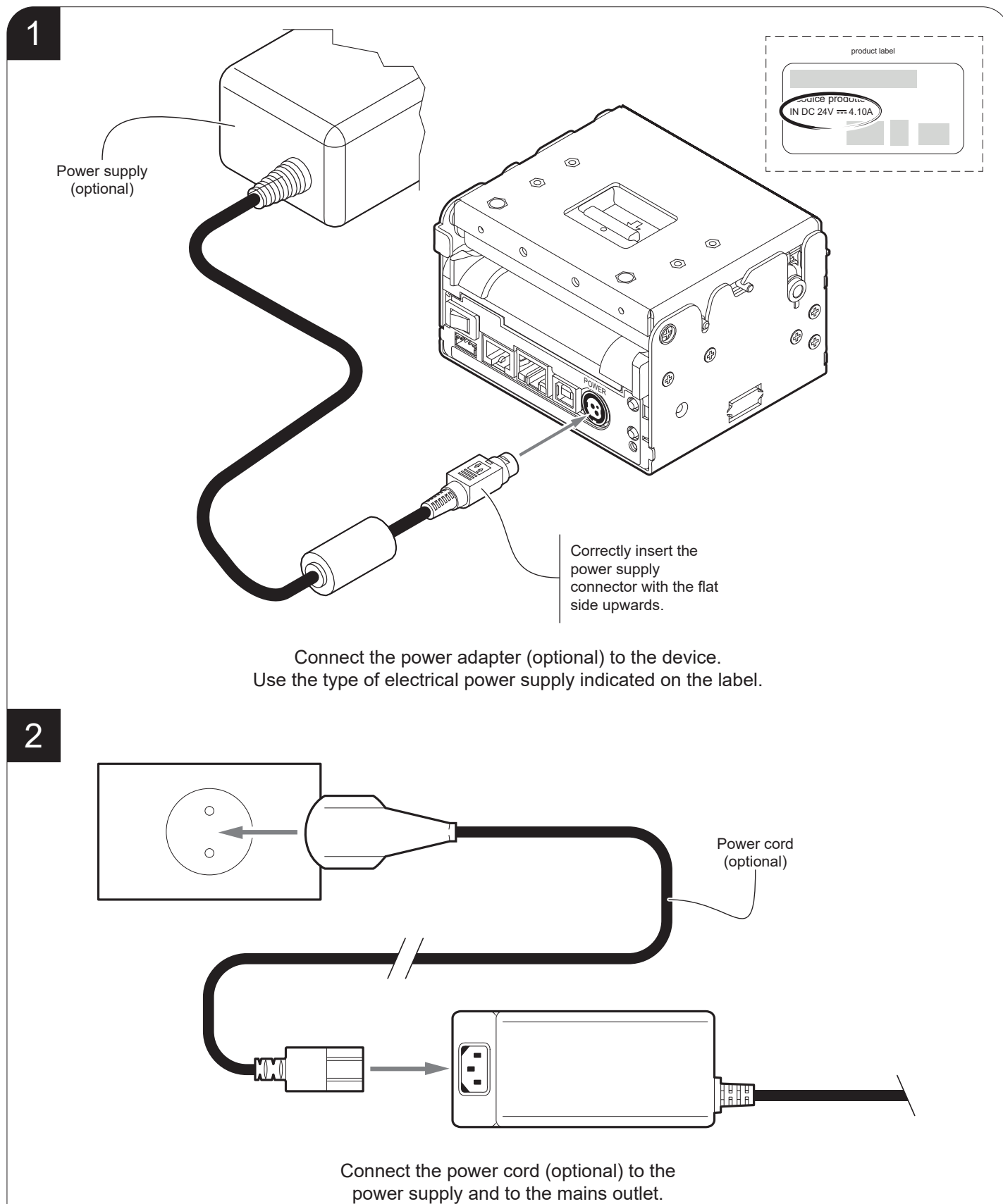



3

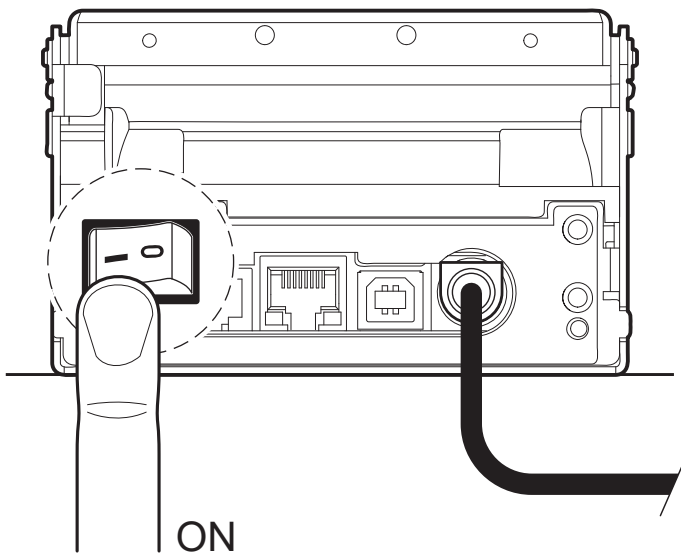

Switch device on  
pressing the ON/OFF key.

4

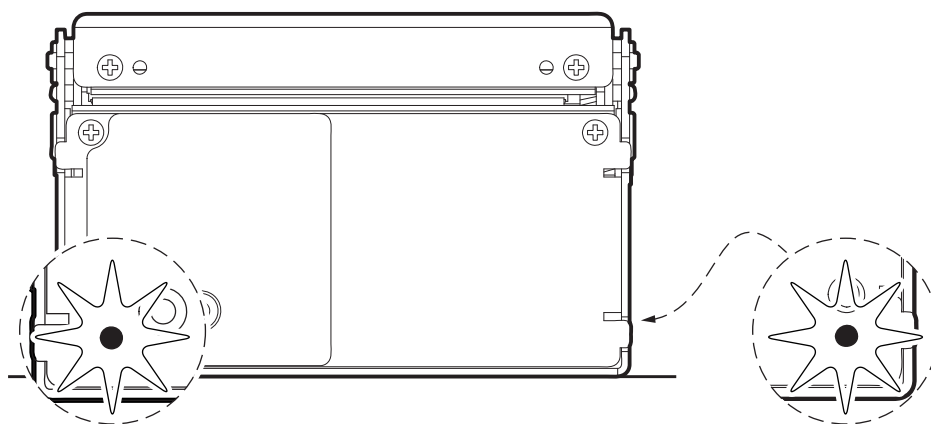

The green LEDs (front and rear) turn on  
and the device is ready.

**TK180 MET 1, TK180 MET 2, TK180 MET 3**  
**TK180 CUT 1, TK180 CUT 2, TK180 CUT 3**

1

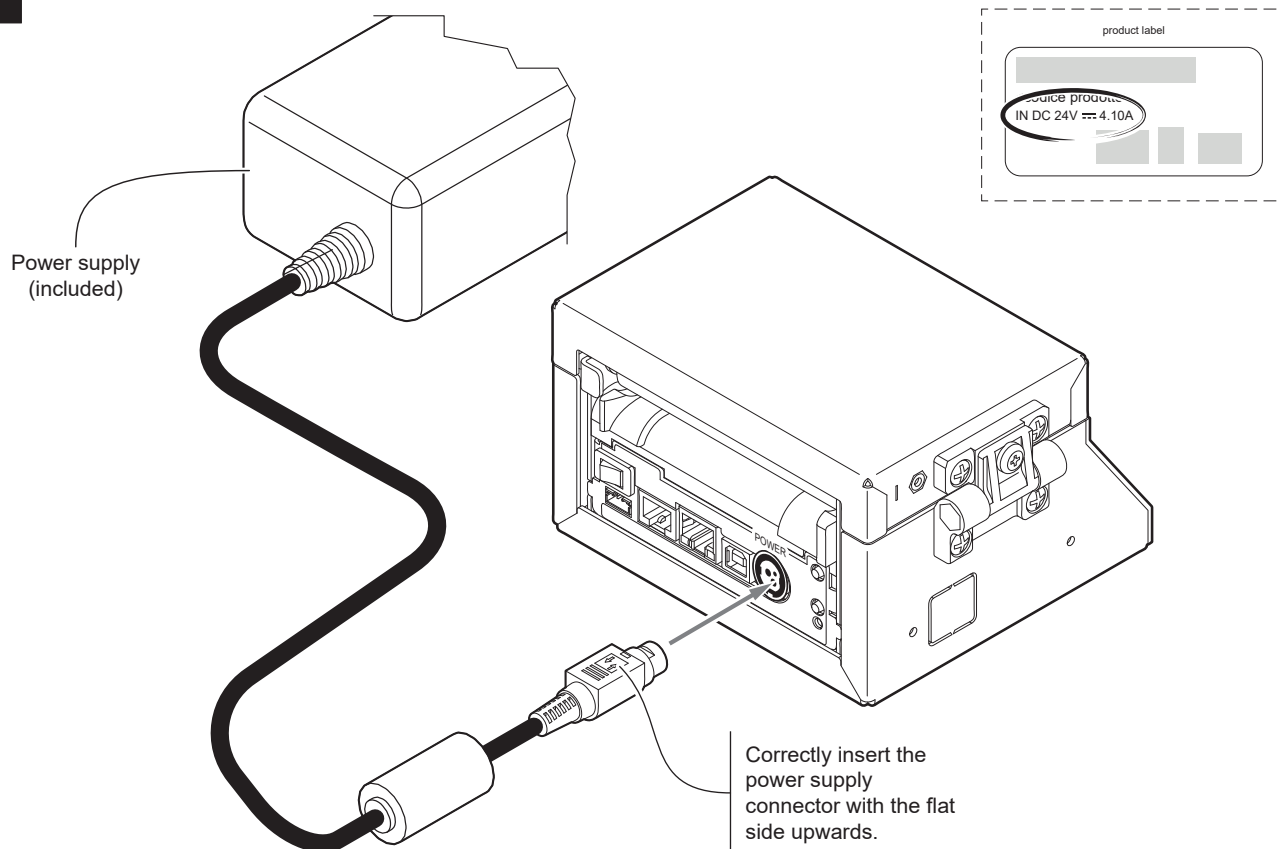

Connect the power adapter to the device.  
Use the type of electrical power supply indicated on the label.

2

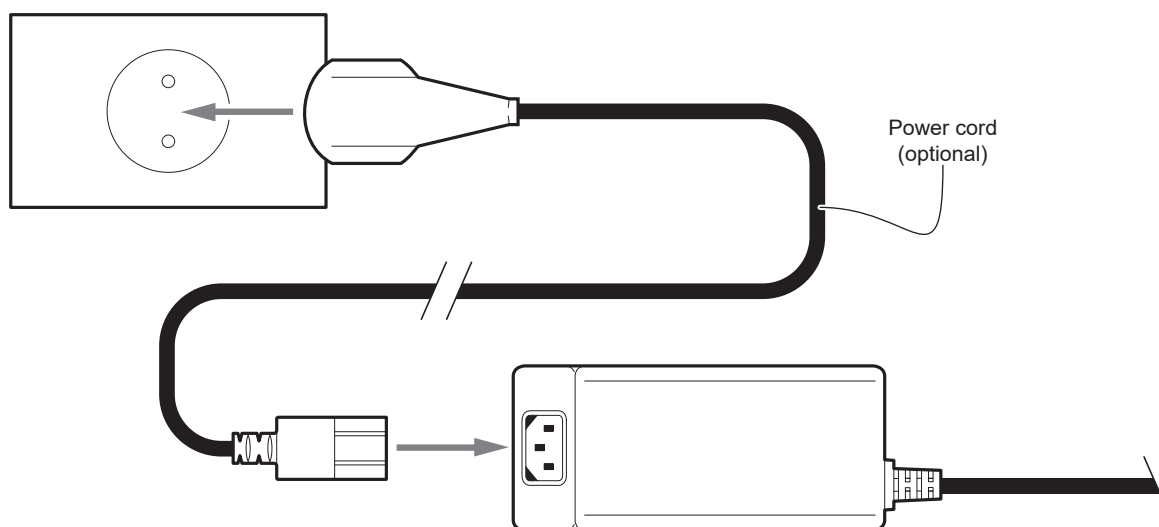

Connect the power cord (optional) to the power supply and to the mains outlet.

3

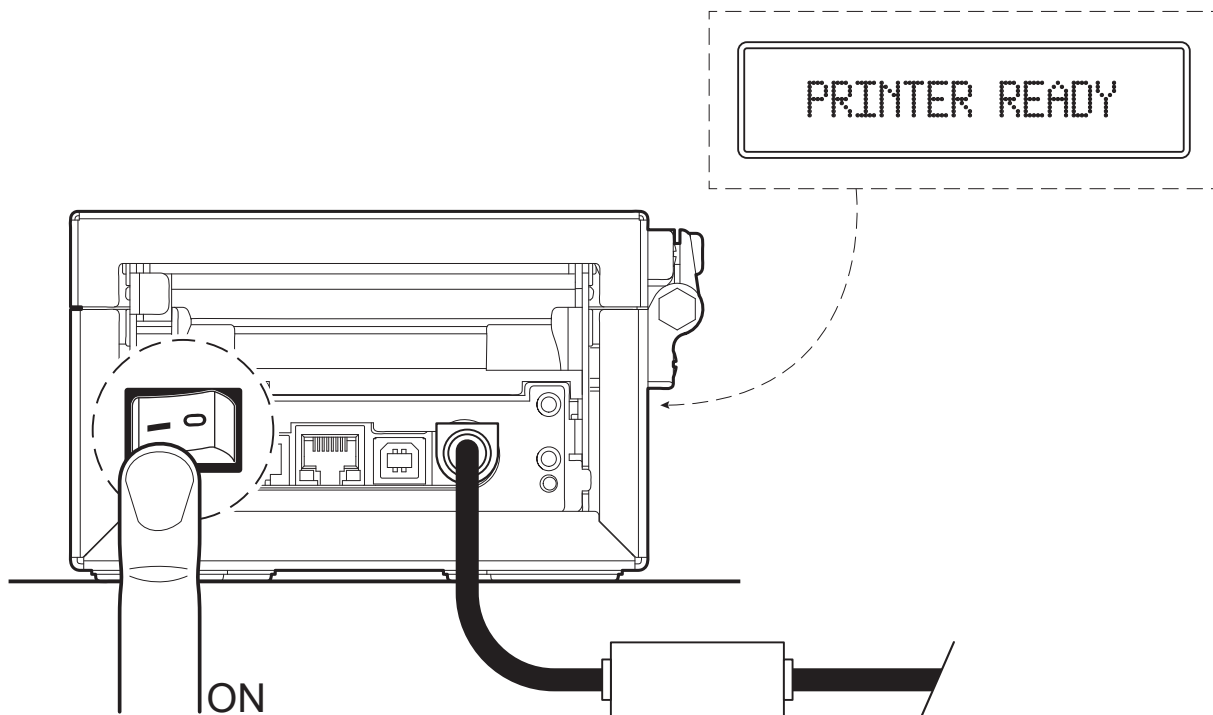

Switch device on pressing the ON/OFF key.  
The display turns on and shows the message in figure.

**TK180 PLAS 1, TK180 PLAS 3**

1

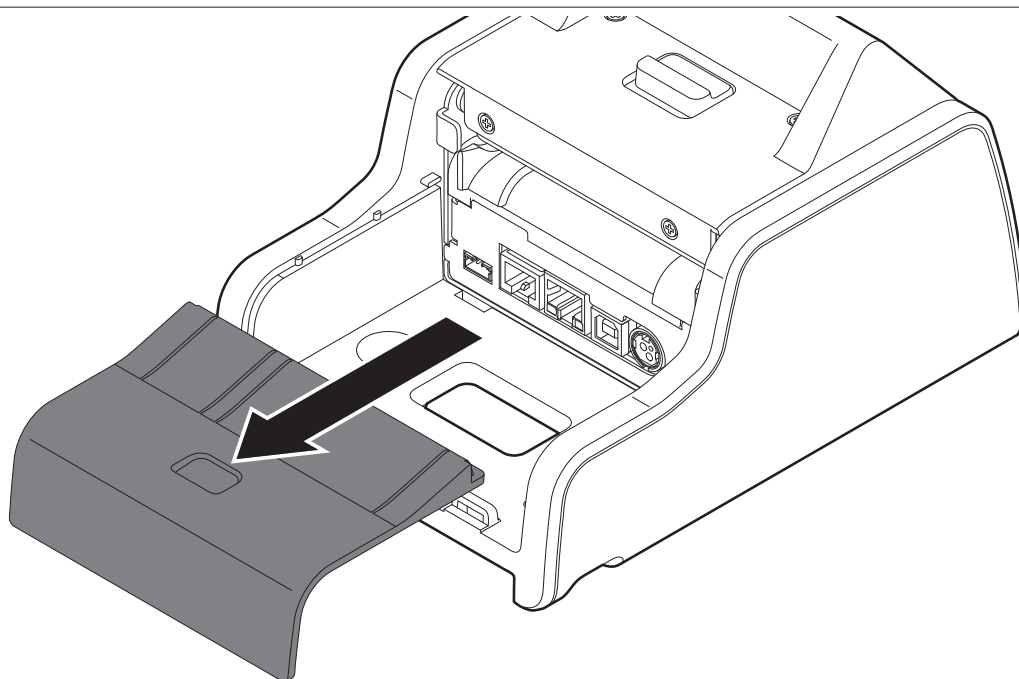

Remove the cover of the connector compartment  
by sliding it in the direction shown.

2

Place the ferrite core of the power supply cable inside the connectors compartment.

Correctly insert the power supply connector with the flat side upwards.

Power supply (included)

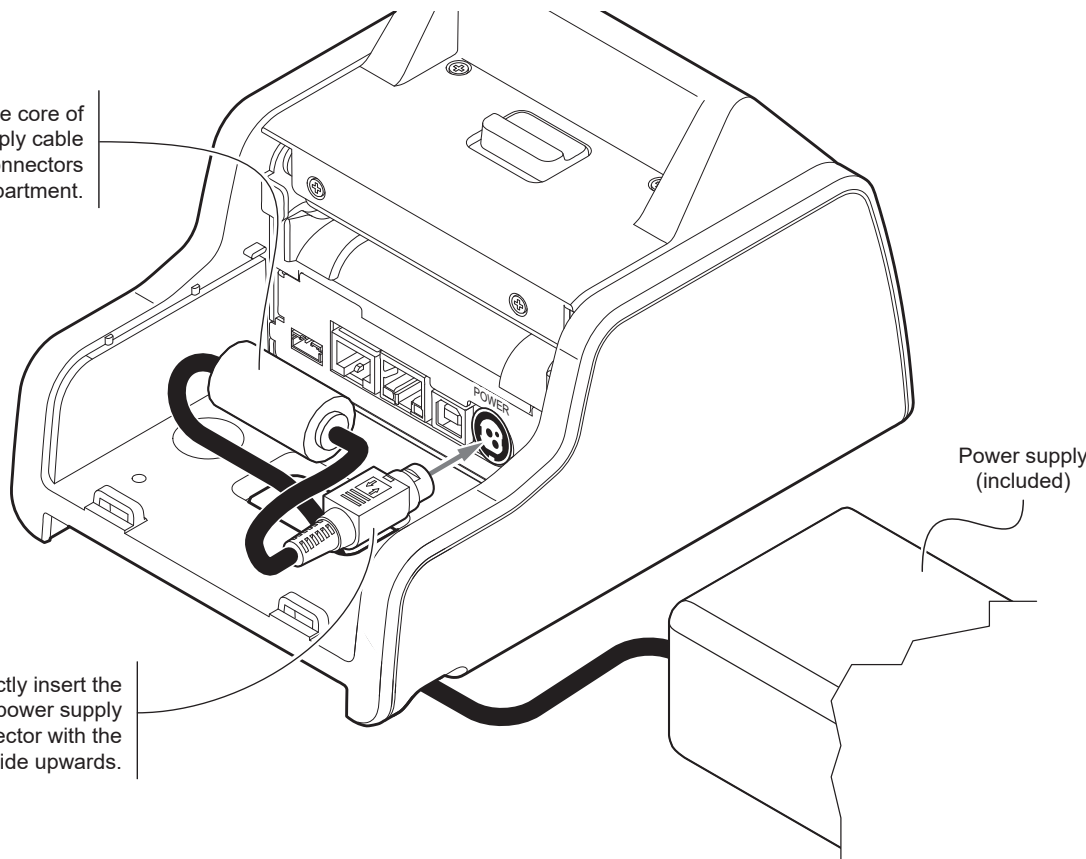

Connect the power adapter to the device by placing the cable as shown. Use the type of electrical power supply indicated on the label.

3

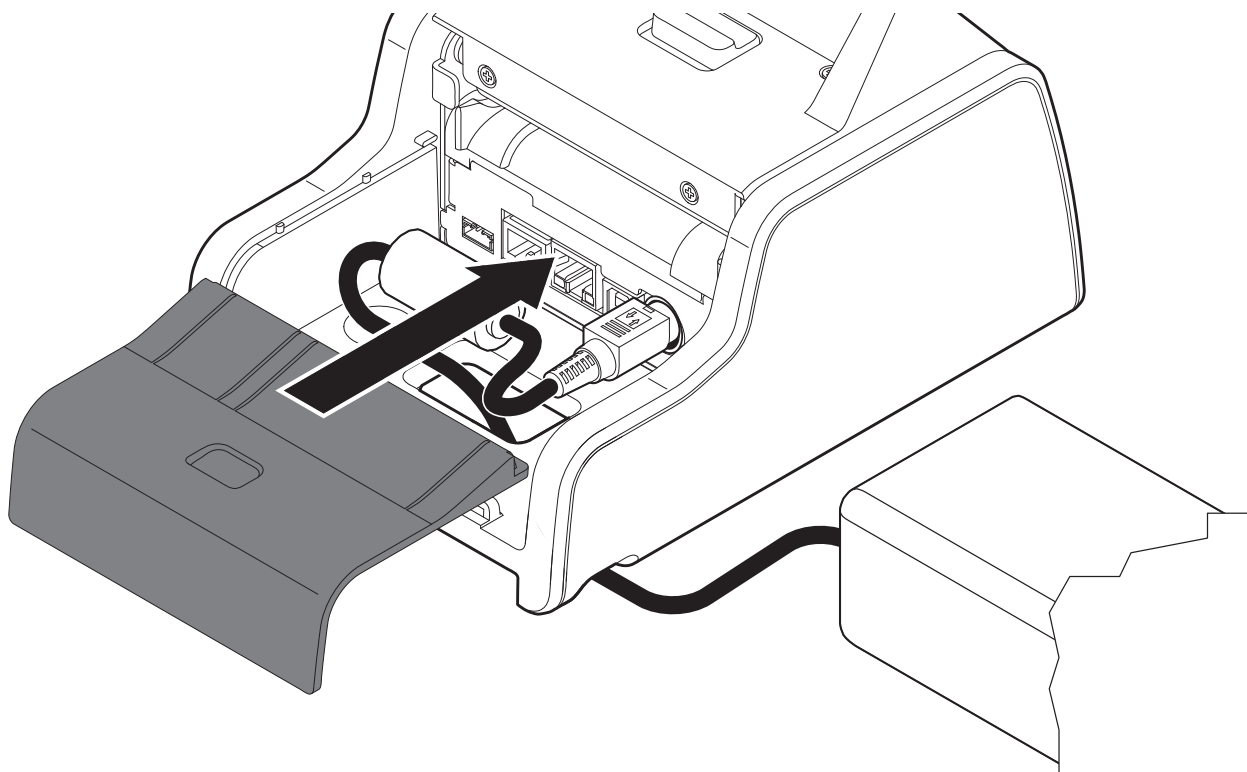

Close the connectors compartment by placing the cover previously removed.

4

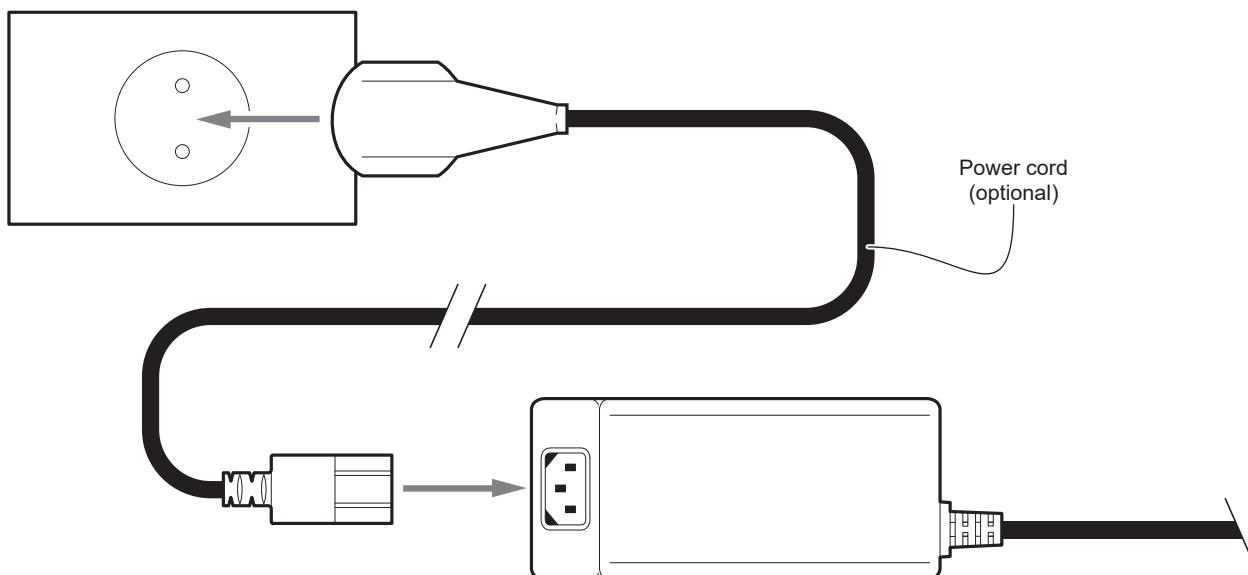

Connect the power cord (optional) to the power supply and the mains outlet.

5

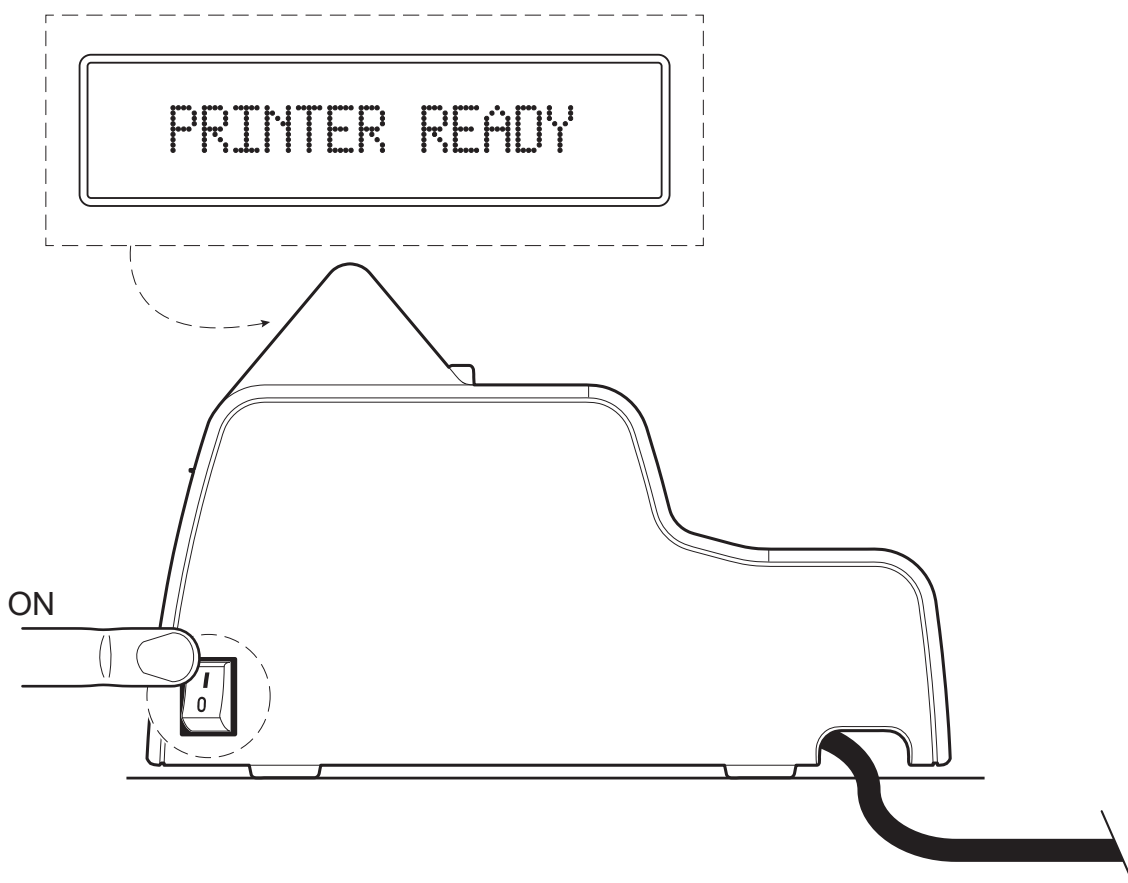

Switch device on pressing the ON/OFF key.  
The display turns on and shows the message in figure.

1

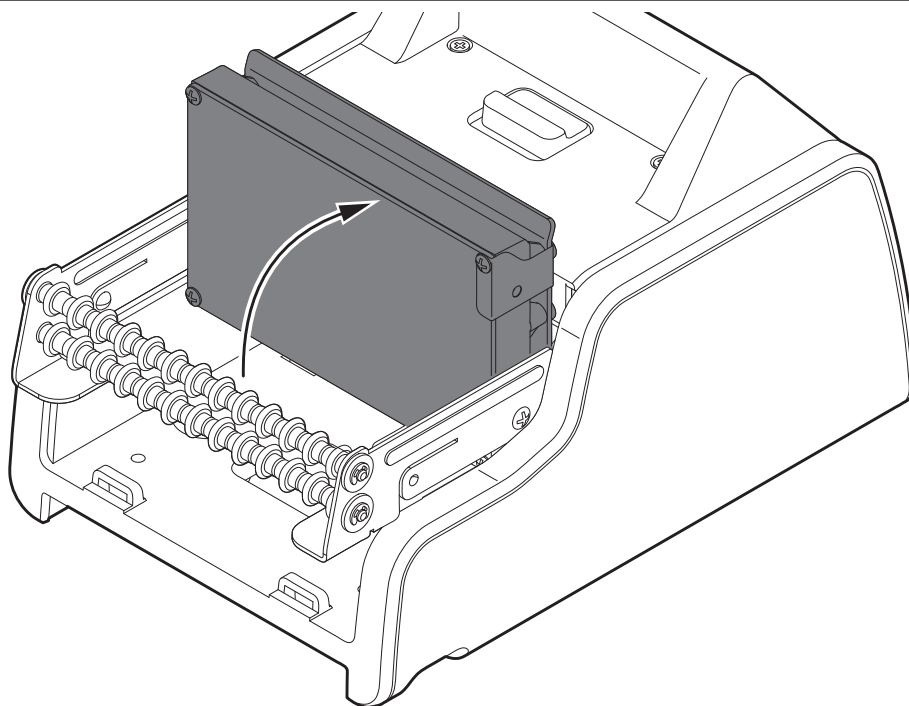

Lift the RFID reader by rotating it in the shown direction.

2

Place the ferrite core of the power supply cable inside the connectors compartment.

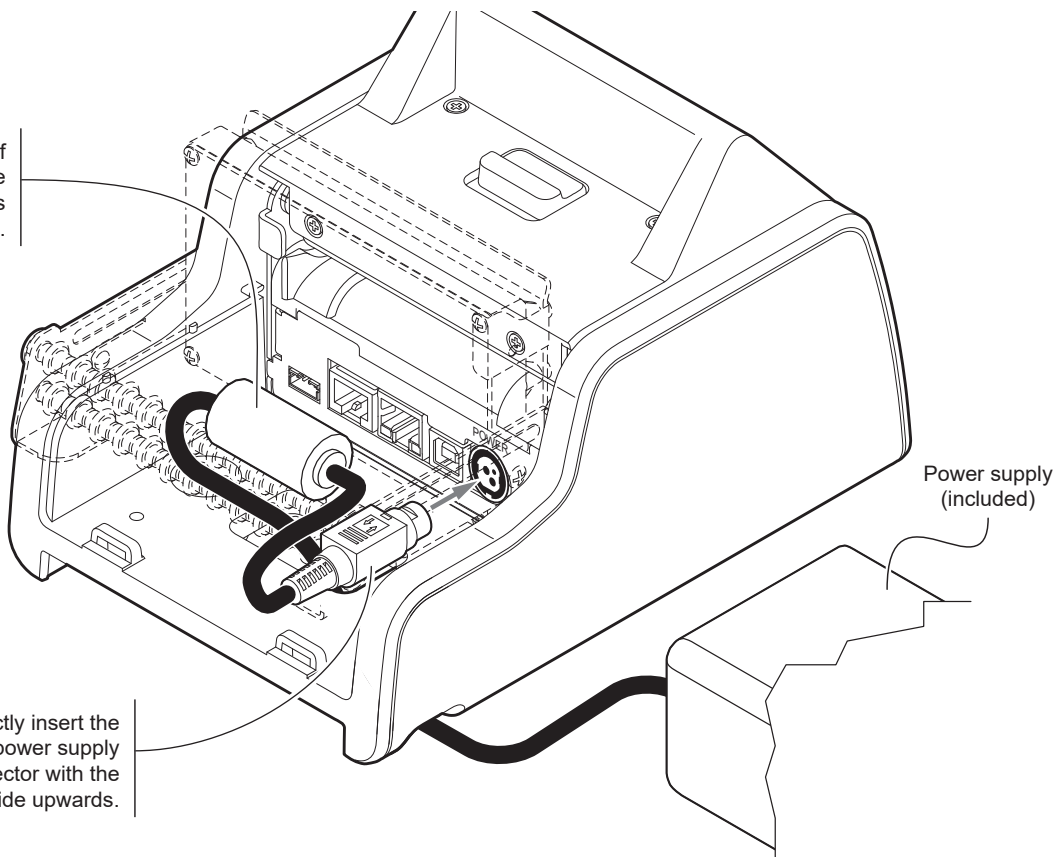

Connect the power adapter to the device by placing the cable as shown. Use the type of electrical power supply indicated on the label.

3

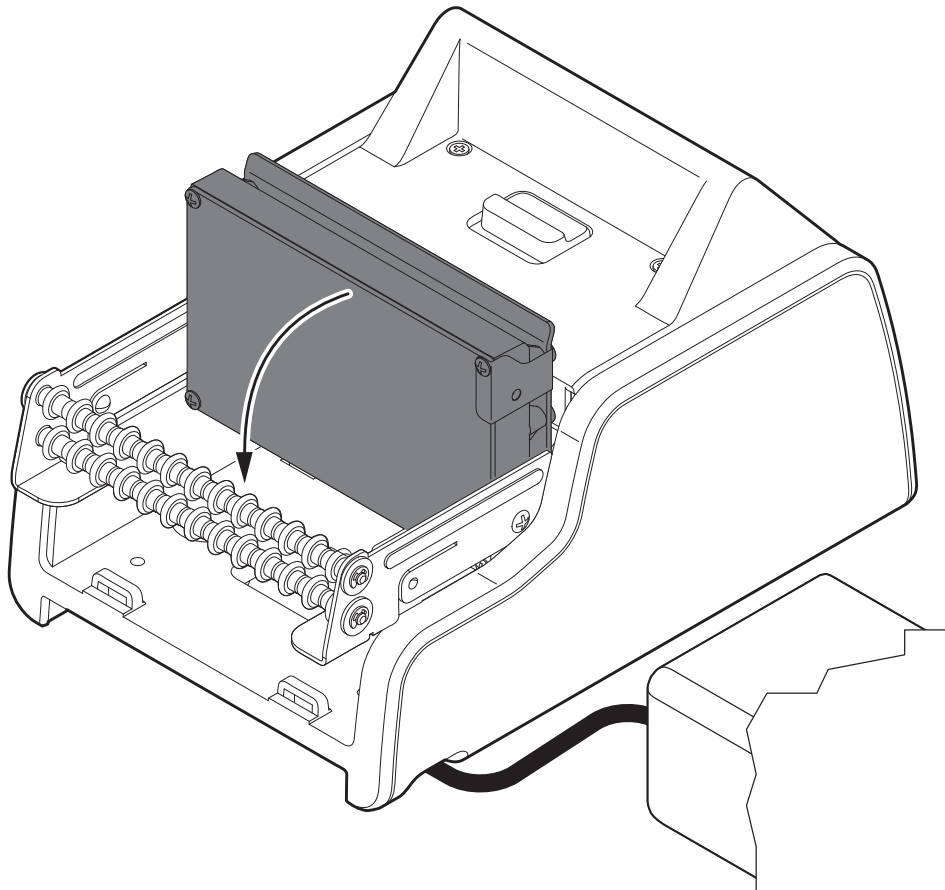

Lower the RFID reader by rotating it in the shown direction.

4

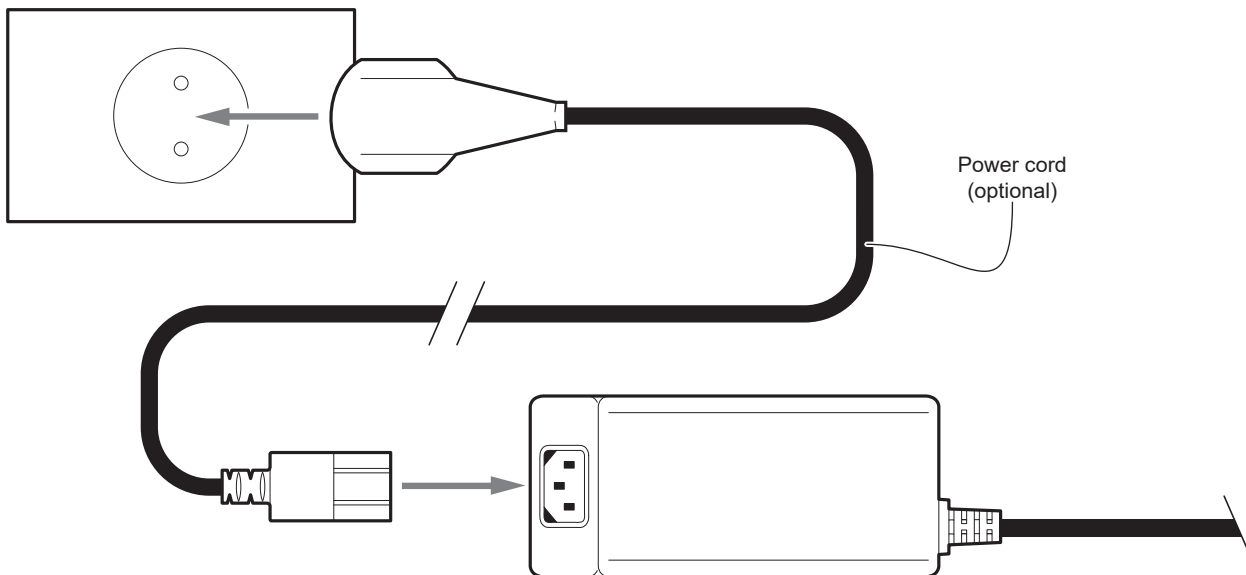

Connect the power cord (optional) to the power supply and the mains outlet.

5

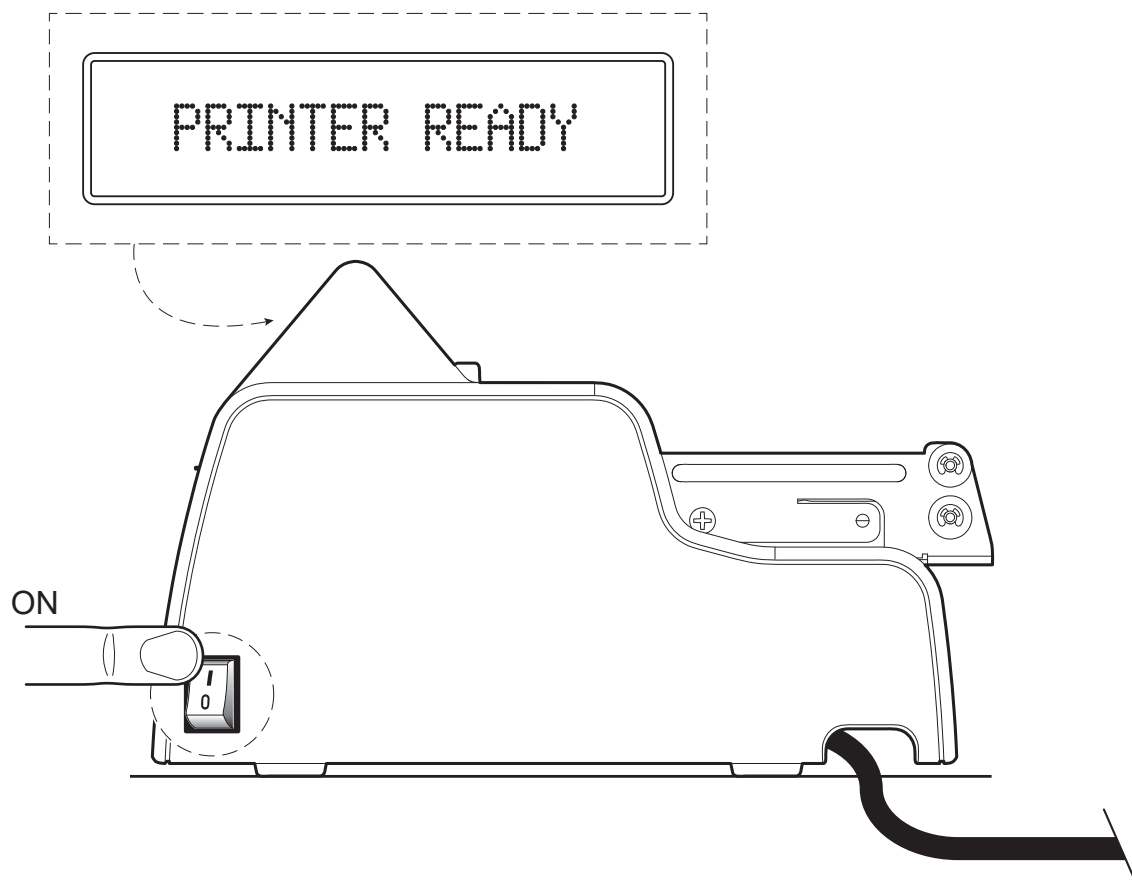

Switch device on pressing the ON/OFF key.  
The display turns on and shows the message in figure.



## 5.9 Loading the paper roll

To change the paper proceed as follows (for some models, only the internal printer group is represented).  
At every change of paper, check inside the device to locate and remove any scraps of paper.

1

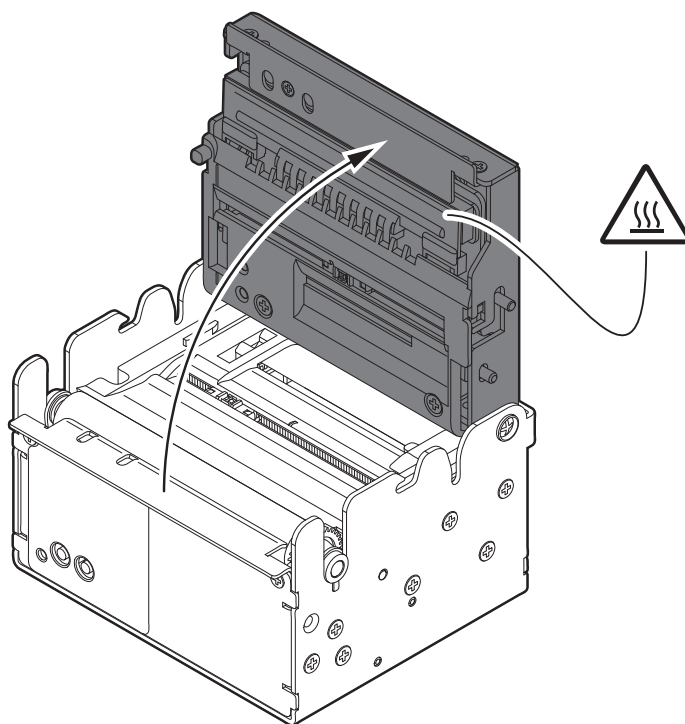

Open the device cover  
(see [paragraph 5.1](#))

2

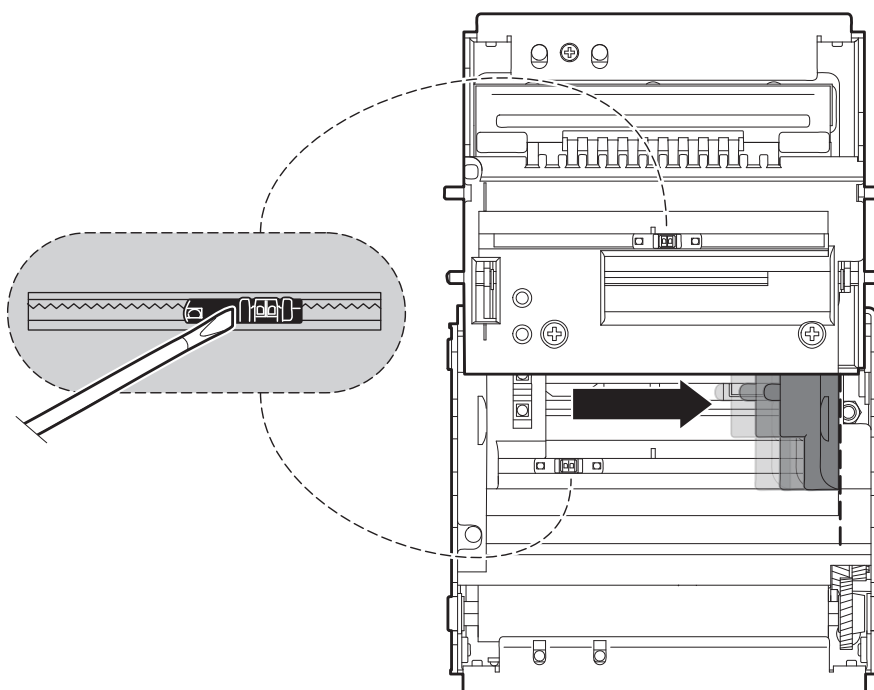

Adjust the paper width (see [paragraph 5.2](#))  
and the black mark sensor position (see [paragraph 5.7](#)).

3

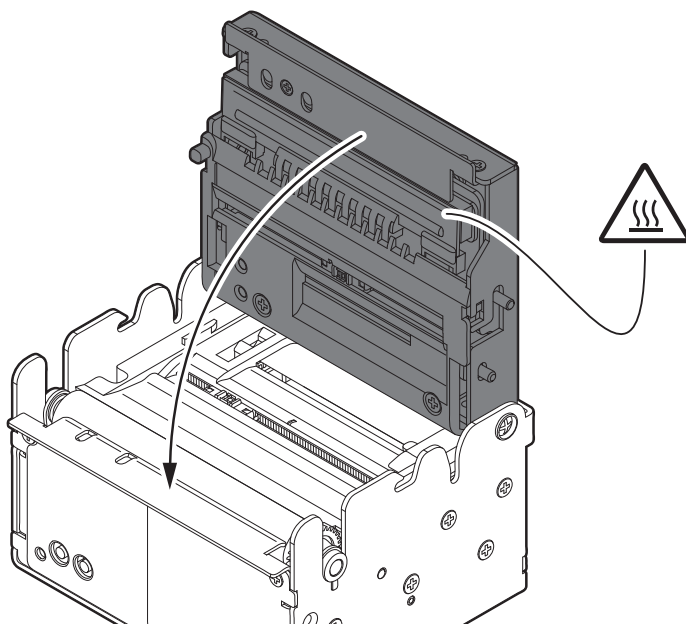

Close the device cover.

4

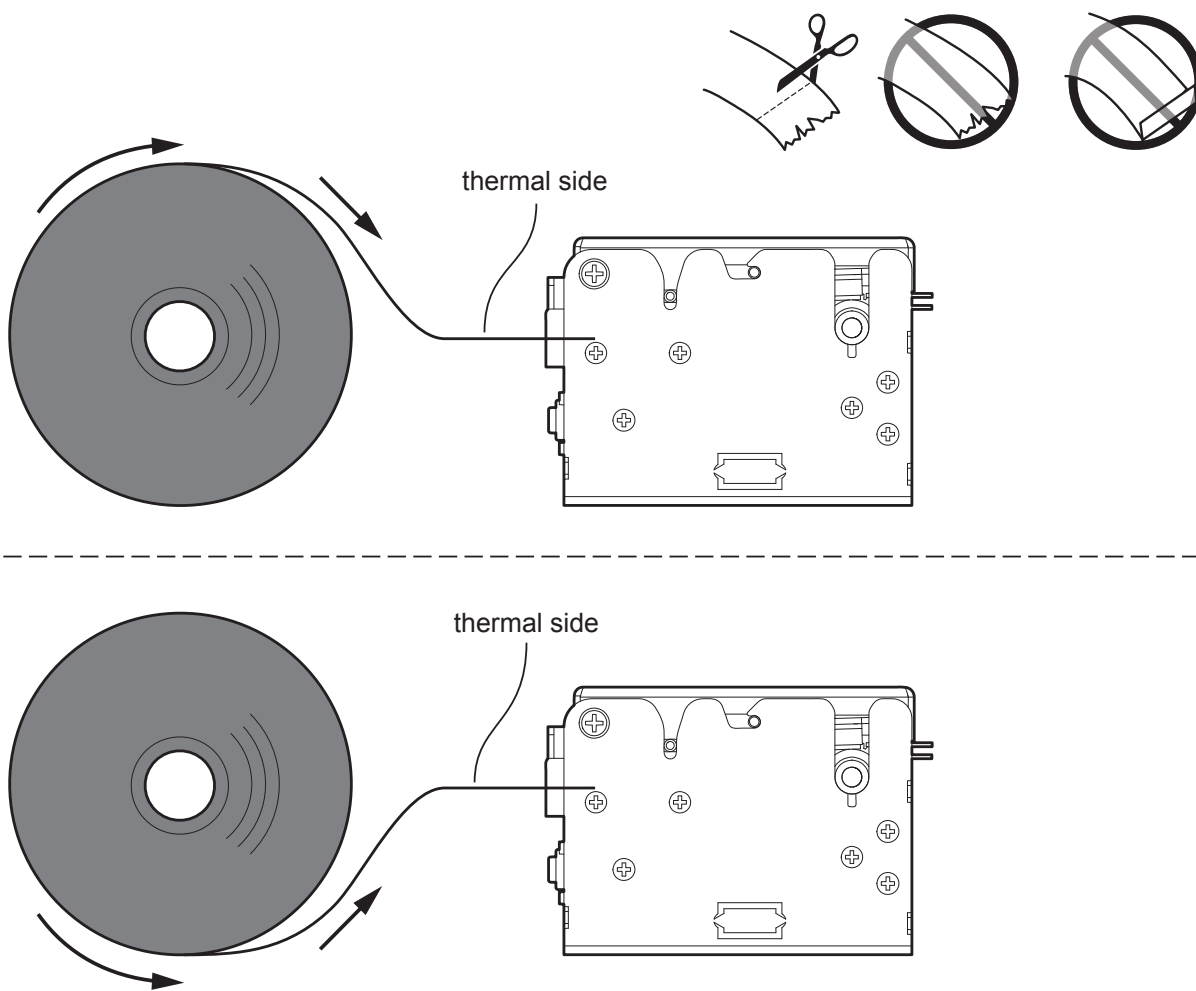

Insert the paper into the input mouth so that it unrolls correctly.  
Be sure that the paper is correctly positioned into paper guides.

5

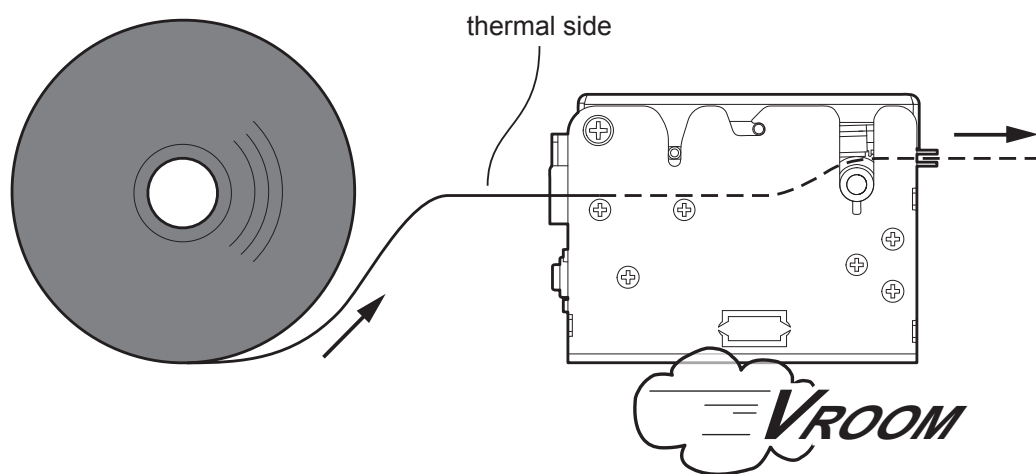
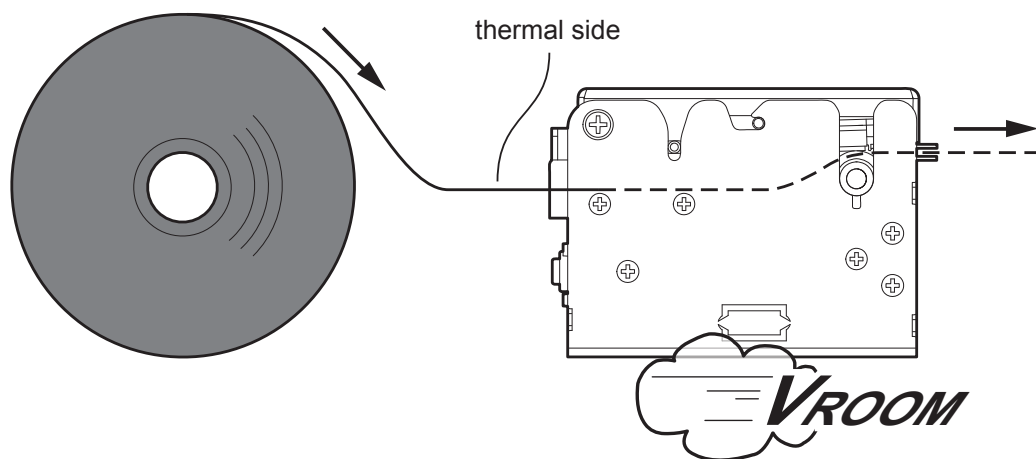

Wait until the paper is automatically loaded.



The following figure gives the limit positions of the paper roll related to the device for a correct paper loading without a paper roll holder support (for some models, only the internal printer group is represented). The direction of the paper will always form a maximum angle of  $90^\circ$  or  $-90^\circ$  with the insertion plane of paper inside the device.

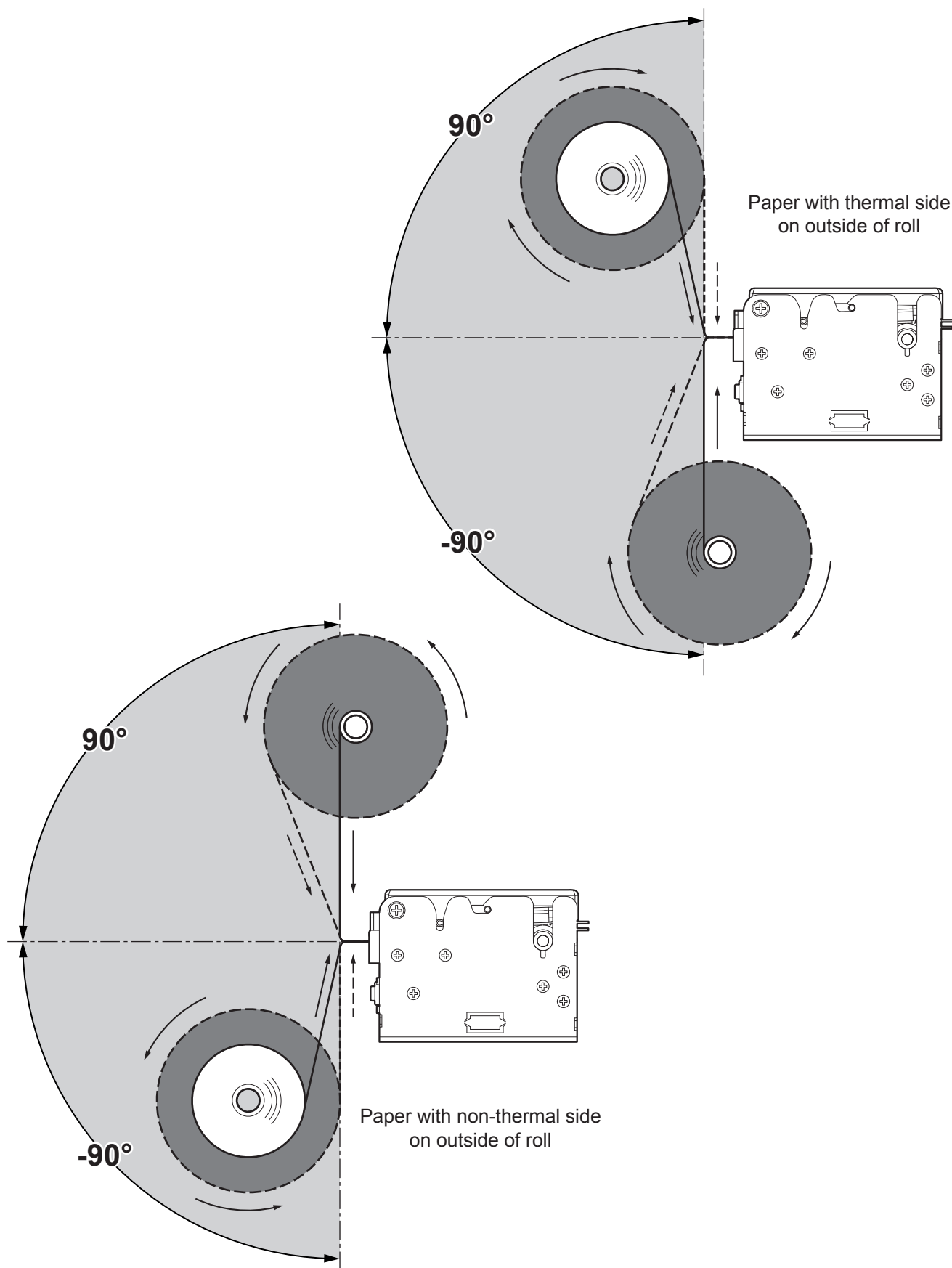

## 5.10 Issuing ticket

**KPM180H 2, KPM180H 3, KPM180H 4, KPM180H 5, KPM180H 6**  
**TK180 CUT 1, TK180 CUT 2, TK180 CUT 3**

The device allows the following operating mode for the issuance of printed tickets. The operating mode shown in the following images, depend on the settings of the configuration parameters and commands sent to the device (see [chapter 6](#) and commands manual of the device).

For some models, only the internal printer group is represented.

### **"PRESENT" mode**

1

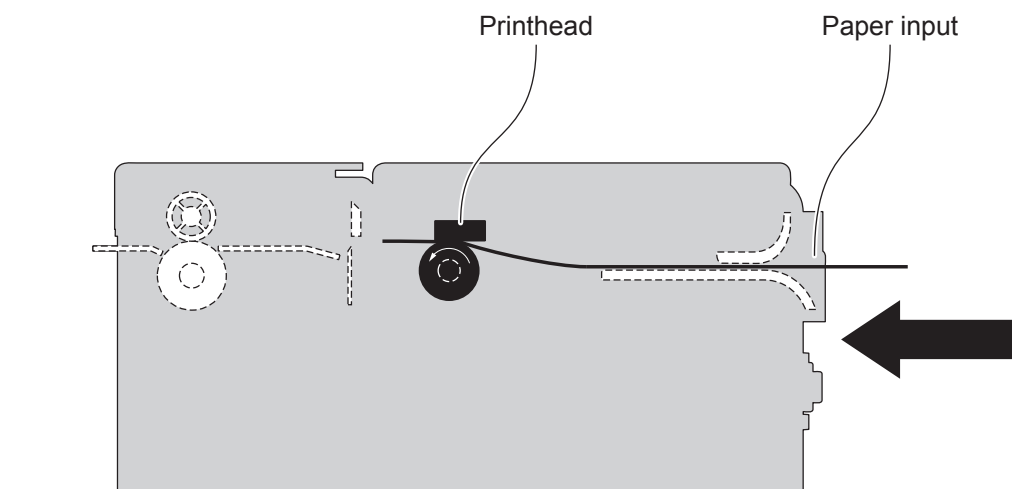

The device starts the ticket printing.

2

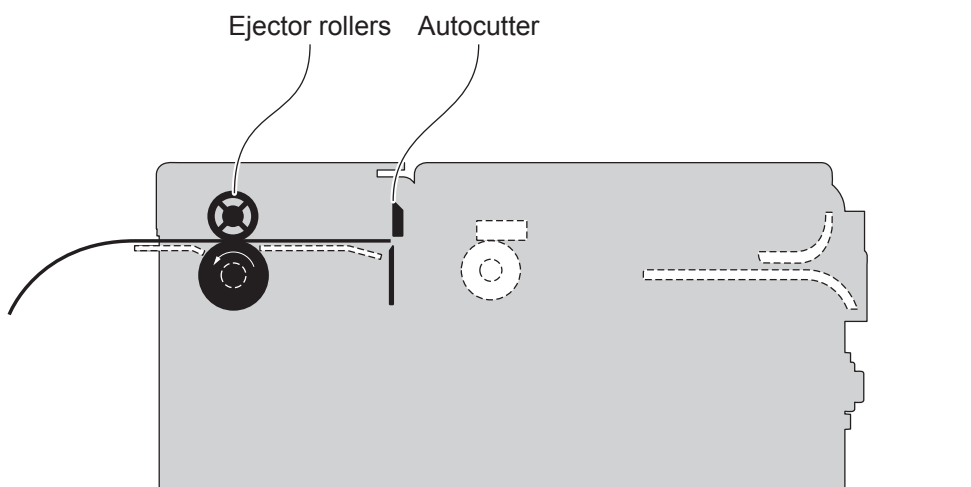

When printing ends, the device cuts the ticket printed.

3

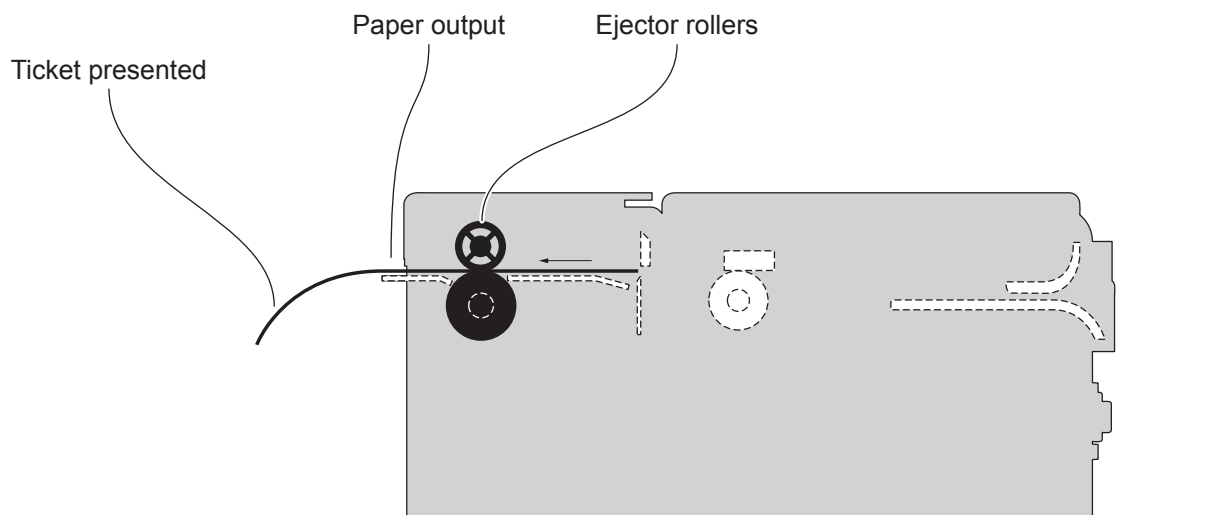

The device presents a portion of the ticket printed and hold it between the ejector rollers.

4

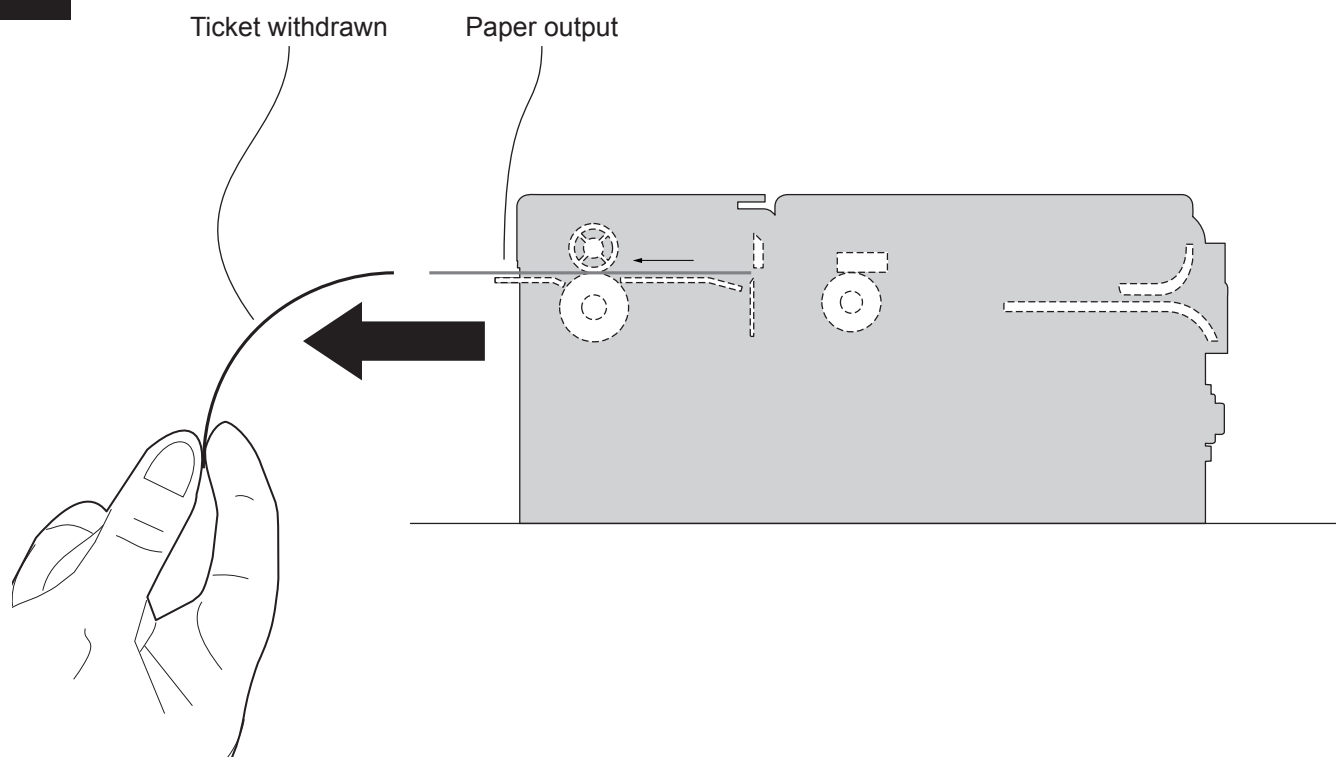

The user withdraws the ticket printed.



## 5.11 License activation for RFID tag reading

KPM180H 6

TK180 CUT 3, TK180 MET 3

TK180 PLAS 3

The device models with internal RFID reader/writer are equipped with an RFID transceiver, provided with antenna, that allows to send and receive RF data to and from the tag (see [paragraph 9.10](#)).

To activate and use this feature, it is necessary to purchase a specific license. Contact the technical support or your dealer.





# 6 CONFIGURATION

## 6.1 Configuration by keys

To enter the configuration mode and print a setup report with the operating parameters of the device, proceed as follows.

1

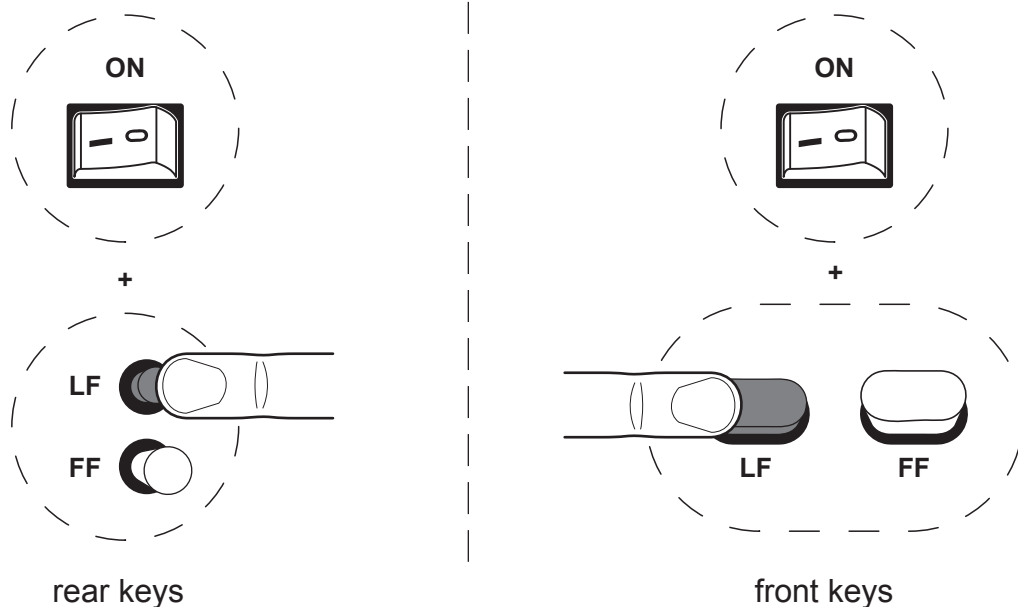

While pressing the LF LINE FEED key, switch on the device by pressing the ON/OFF key.

2



The device prints the report with the settings parameters. Follow the instruction printed on the paper or shown on display to proceed with configuration procedure.



The following figure shows the setup report of the device. The shown values for parameters are sample values; for the list and the description of device parameters see the following paragraphs.

DEVICE NAME AND  
FIRMWARE MODULES  
RELEASE

```

<device name>
SCODE. <code>           - rel 1.00
DCODE. <code>           - rel 1.00
FCODE. <code>           - rel 1.00
  
```

PRINthead  
STATUS

```

PRINTER SETTINGS
1 «*****» 640
-----
PRINthead WORKING GOOD!
  
```

DEVICE  
STATUS

```

PRINTER TYPE .....<device model>
RFID Module .....Not Present
Wi-Fi Module .....Not Present
PRINTING HEAD TYPE.....<head model>
INTERFACE .....RS232
PROGRAM MEMORY TEST.....OK
DYNAMIC RAM TEST.....OK
EXTERNAL MEMORY TEST .....OK
CUTTER TEST.....OK
HEAD VOLTAGE           [V] = 23,37
HEAD TEMPERATURE      [°C] = 25
POWER ON COUNTER      = 4
PAPER PRINTED         [cm] = 40
CUT COUNTER           = 1
DATE - TIME           = <date-time>
  
```

PRINTER  
PARAMETERS

```

Wireless.....: Off
Printer Emulation.....: CUSTOM POS
RS232 Baud Rate .....: 115200 bps
RS232 Data Length.....: 8 bits/chr
RS232 Parity .....: None
RS232 Handshaking .....: Hardware
Busy Condition .....: RxFull
USB Address Number .....: 0
USB Class .....: Printer
Print Mode .....: Normal
Autofeed .....: CR Disabled
Code Table [num] .....: 0
Chinese Font .....: Disabled
Chars / inch .....: A=15 B=20 cpi
Speed / Quality.....: Normal
Print Width.....: 80 mm
Paper Threshold.....: 40%
Black mark Position.....: Bottom
Black mark Threshold.....: 40%
Black mark Distance [mm].....: +00.0
Black mark Min.Width.....: 0 mm
Auto stop at B.Mark.....: Disabled
Ticket Locking.....: Disabled
Ticket Management.....: Disabled
PrintHead Test PowerOn.....: Disabled
Casing Type.....: Plastic
Cut Recovery.....: After cut
Print Density.....: 0%
  
```

KEYS  
FUNCTIONS

```

[ LF ] enter Setup
[ FF ] skip Setup
  
```



The following figure shows the setup report of the Ethernet parameters. The shown values for parameters are sample values; for the list and the description of device parameters see the following paragraphs.

ETHERNET PARAMETERS	}	ETH. SPEED = 10Mb/s
		DHCP Client .....: <b>Disabled</b>
		IP Address .....: <b>192.168. 0. 1</b>
		Subnet Mask .....: <b>255.255.240. 0</b>
		Default Gateway .....: <b>192.168. 0. 5</b>
		MAC Address .....: <b>00-0E-E2-0A-D2-D0</b>
KEYS FUNCTIONS	}	[ LF ] to modify parameter
		[ FF ] for next parameter

## 6.2 Configuration by software

The configuration parameters can be set by the "PrinterSet" software tool available on [www.custom4u.it](http://www.custom4u.it). For a detailed description of operating parameters for the device, see the following paragraphs.

To set the device by software, proceed as follows.

1

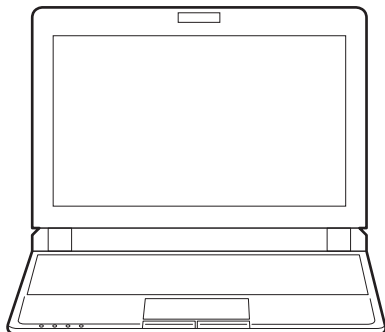

Connect the device to a PC directly (see [paragraph 4.3](#)), without using HUB devices.

2

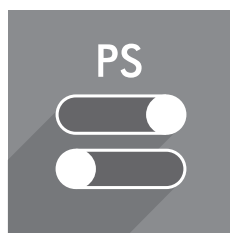

Start "PrinterSet" software tool.

3

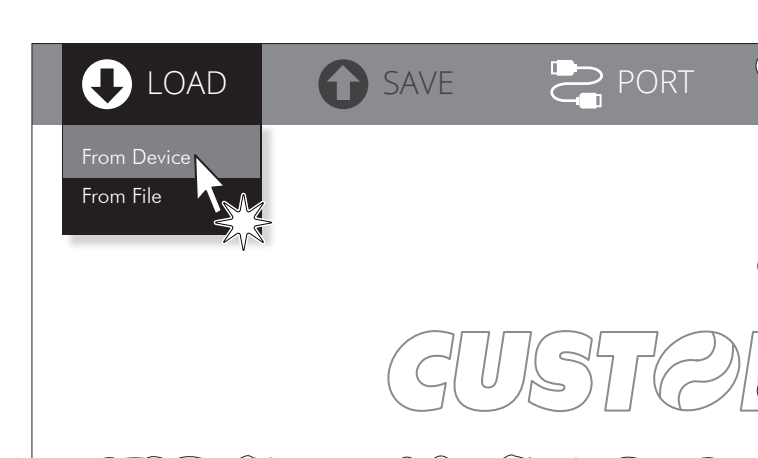

Click on LOAD > FROM DEVICE and select the device connected to the PC.

4

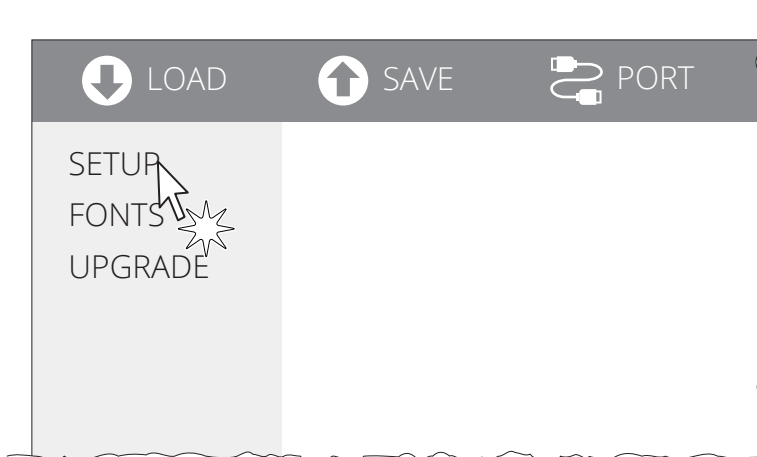

Click on SETUP to access the operating parameters of the device to be configured.

5

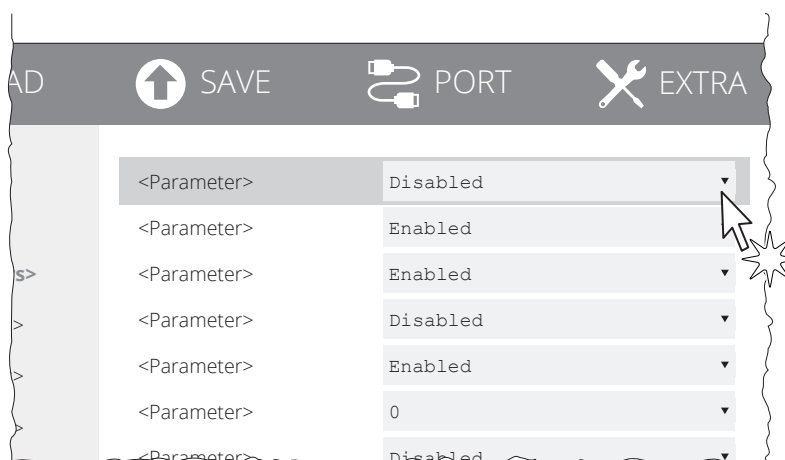

Make the desired changes to the device operating parameters.

6

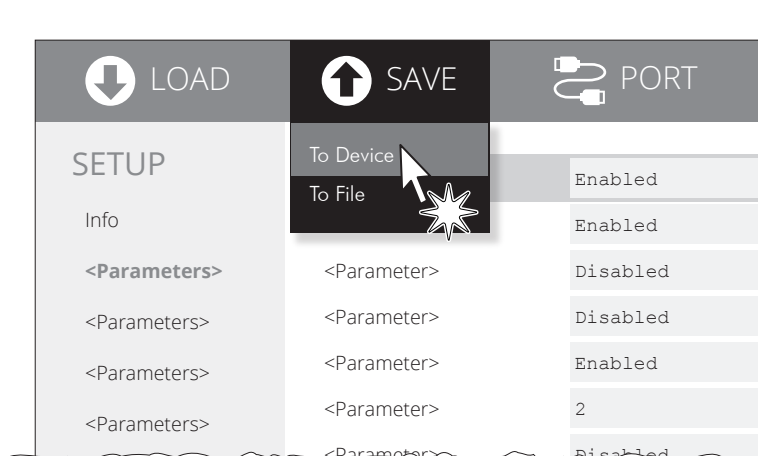

Click on SAVE > TO DEVICE to make the changes made effective.

**ATTENTION:** During the configuration saving, it is strongly advised against disconnecting the communication cable or to remove the power supply of PC or device.

## 6.3 Configuration by file

The configuration parameters can be set by editing the "Setup.ini" file stored on the Flash Drive of the device. Proceed as follows:

1



### Enter setup

Enter the configuration procedure by keys (see [paragraph 6.1](#)) or by software (see [paragraph 6.2](#)).

2

<parameter> ..... : <value>  
<parameter> ..... : <value>  
<parameter> ..... : <value>  
<parameter> ..... : <value>  
~~..... : <value>~~  
**USB Class ..... : Mass storage**  
~~..... : <value>~~  
<parameter> ..... : <value>  
<parameter> ..... : <value>  
<parameter> ..... : <value>  
<parameter> ..... : <value>

Check that the "USB Class" parameter is set to "Mass Storage".  
Otherwise, this configuration mode is not available.

3

USB

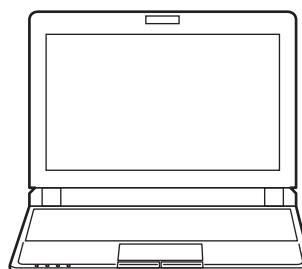

Plug the device to a Personal Computer via USB.

4

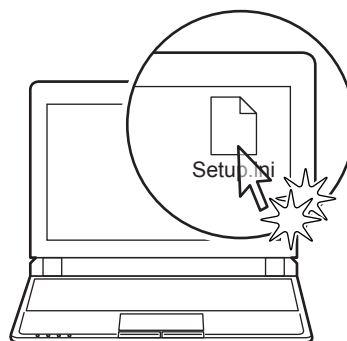

Enter the Flash drive of the device and edit the Setup.ini file.

The "Setup.ini" file is a configuration file that contains all the configurable parameters listed in text format and divided into some sections (indicated between square brackets). For each parameter, you find the parameter name followed by the value currently set and then the available values listed with a reference number. The reference number marked with the symbol '\*' is the default one (see following figure).

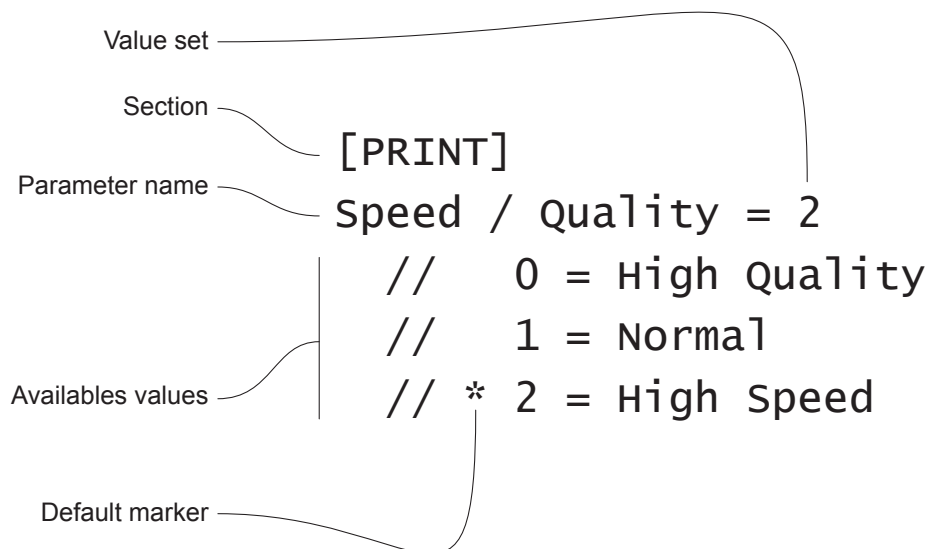

To modify the parameter, change the numeric value after the parameter name or use the default value by typing "D" (default). After editing device's parameter, simply save the "Setup.ini" file to make the modifies activated. For the list and the description of setup parameters see [chapter 6](#).

**ATTENTION:**

The change of value for the "USB Mass Storage" parameter may compromise the access to the Setup.ini file. Be careful to keep the "Enabled" value to allow a new access to the Flash Drive.



## 6.4 Printhead status

The device performs the printhead operating status when printing the setup report. The total number of dots is reported. Are indicated the total dots number of the printhead and their status (see figure below).

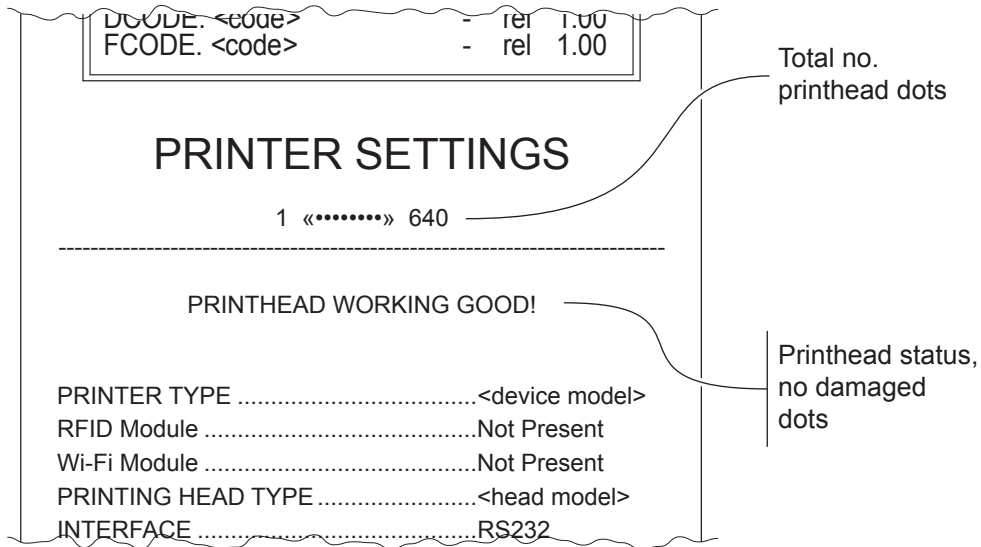

In case of damaged dots, these are listed in the print out in according to their position on the heating line (see figure below).

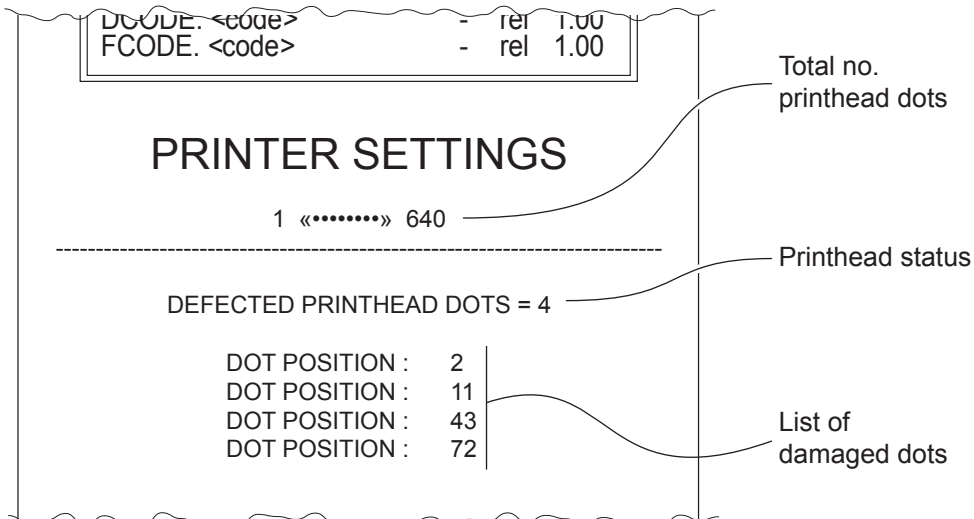





## 6.5 Device status

The device operating status is indicated in the configuration print-out in which, next to the name of the components displayed, the following information is given:

<b>PRINTER TYPE</b>	device model
<b>RFID Module</b>	presence of the RFID reader/writer
<b>Wi-Fi Module <sup>(1)</sup></b>	presence of the Wi-Fi/Bluetooth module
<b>PRINT HEAD TYPE</b>	print head model
<b>INTERFACE</b>	interface present
<b>PROGRAM MEMORY TEST</b>	OK appears if functioning and NOT OK if faulty
<b>DYNAMIC RAM TEST</b>	OK appears if functioning and NOT OK if faulty
<b>EXTERNAL MEMORY TEST</b>	OK appears if functioning and NOT OK if faulty
<b>CUTTER TEST <sup>(2)</sup></b>	OK appears if functioning and NOT OK if faulty
<b>HEAD VOLTAGE</b>	voltage of the head
<b>HEAD TEMPERATURE</b>	temperature of the head
<b>POWER ON COUNTER</b>	number of power-ups made
<b>PAPER PRINTED</b>	centimetres of paper printed
<b>CUT COUNTER <sup>(2)</sup></b>	number of cuts made
<b>DATE - TIME</b>	date and time

**NOTE:**

(1) : Only for TK180 MET 1, TK180 MET 2, TK180 MET 3, TK180 CUT 1, TK180 CUT 2, TK180 CUT 3.

(2) : Only for KPM180H 2, KPM180H 3, KPM180H 4, KPM180H 5, KPM180H 6, TK180 CUT 1, TK180 CUT 2, TK180 CUT 3.



## 6.6 Communication parameters

The parameters marked with the symbol <sup>Ⓓ</sup> are the default values.

Settings remain active even after the device has been turned off and they are stored in non-volatile memory.

---

<b>WIRELESS</b>	Activation of wireless communication:  Off <sup>Ⓓ</sup> On  The parameter is printed on setup report and has effect on device configuration only for TK180 MET 1, TK180 MET 2, TK180 CUT 1, TK180 CUT 2
-----------------	--

---

<b>RS232 BAUD RATE</b>	Communication speed of the serial interface.  115200 <sup>Ⓓ</sup> 9600 57600            4800 38400            2400 19200  This parameter is valid only with serial interface.
------------------------	--

---

<b>RS232 DATA LENGTH</b>	Number of bit used for characters encoding.  7 bits/car 8 bits/car <sup>Ⓓ</sup>  This parameter is valid only with serial interface.
--------------------------	---

---

<b>RS232 PARITY</b>	Bit for the parity control of the serial interface.  None <sup>Ⓓ</sup> = parity bit omitted Even    = even value for parity bit Odd     = odd value for parity bit  This parameter is valid only with serial interface.
---------------------	---

---

<b>RS232 HANDSHAKING</b>	Handshaking.  XON/XOFF = software handshaking Hardware <sup>Ⓓ</sup> = hardware handshaking (CTS/RTS)  This parameter is valid only with serial interface.  When the receive buffer is full, if handshaking is set to XON/XOFF, the device sends the XOFF (0x13) on the serial port. When the receive buffer has cleared once again, if handshaking is set to XON/XOFF, the device sends the XON (0x11) on the serial port.
--------------------------	---

---

<b>BUSY CONDITION</b>	Activation mode for busy signal:  Offline/RXFull = busy signal is activated when the device is both in Offline status and the buffer is full RXFull <sup>Ⓓ</sup> = busy signal is activated when the buffer is full  This parameter is valid only with serial interface.
-----------------------	---

---



---

<b>USB ADDRESS NUMBER</b>	<p>Numerical address code for the univocal identification of the USB device (in case of more than a USB device connected with the same PC).</p> <table><tr><td>0 <sup>D</sup></td><td>2</td><td>4</td><td>6</td><td>8</td></tr><tr><td>1</td><td>3</td><td>5</td><td>7</td><td>9</td></tr></table>	0 <sup>D</sup>	2	4	6	8	1	3	5	7	9
0 <sup>D</sup>	2	4	6	8							
1	3	5	7	9							

---

<b>USB CLASS</b>	<p>USB communication class definition.</p> <p>Printer <sup>D</sup> = setting the printer function Mass Storage = setting the sharing mode from Mass Storage Virtual COM = setting the USB port as a virtual serial port</p> <p>To use the value "Virtual COM", it is necessary to install an additional driver (see <a href="#">paragraph 4.5</a>)</p>
------------------	--

---

<b>DHCP CLIENT</b>	<p>Setting of the DHCP protocol:</p> <p>Disabled <sup>D</sup> = protocol disabled Enabled = protocol enabled</p> <p>This parameter can be modified by software (see <a href="#">paragraph 6.2</a>) and by file (see <a href="#">paragraph 6.3</a>).</p>
--------------------	---

---

<b>IP ADDRESS</b>	<p>This is the IP address of device, assigned by the network administrator. This parameter can be modified by software (see <a href="#">paragraph 6.2</a>) and by file (see <a href="#">paragraph 6.3</a>).</p>
-------------------	---

---

<b>SUBNET MASK</b>	<p>This parameter identifies the local network address. It can be modified by software (see <a href="#">paragraph 6.2</a>) and by file (see <a href="#">paragraph 6.3</a>).</p>
--------------------	---

---

<b>DEFAULT GATEWAY</b>	<p>This parameter identifies the Gateway IP address used to send applications to the external network. It can be modified by software (see <a href="#">paragraph 6.2</a>) and by file (see <a href="#">paragraph 6.3</a>).</p>
------------------------	--

---

<b>DOMAIN NAME SYSTEM</b>	<p>This parameter identifies the Domain Name System (DNS). It is not printed on setup report, because it can be modified only by file (see <a href="#">paragraph 6.3</a>).</p>
---------------------------	--

---

<b>TCP PRINTER PORT</b>	<p>This parameter sets the TCP port number. It is not printed on setup report, because it can be modified only by file (see <a href="#">paragraph 6.3</a>).</p>
-------------------------	---

---

<b>MAC ADDRESS</b>	<p>This is the number, provided by the constructor, that identifies the device; this number is univocal. It can be modified by software (see <a href="#">paragraph 6.2</a>) and by file (see <a href="#">paragraph 6.3</a>).</p>
--------------------	--

---

**ATTENTION:**

Any changes to network parameters will interrupt browser connection. If the server not responding you must reconnect to the new IP address set.



## 6.7 Operation parameters

The parameters marked with the symbol <sup>Ⓓ</sup> are the default values.  
Settings remain active even after the device has been turned off and they are stored in non-volatile memory.

---

**PRINTER EMULATION** Available emulations for the device.

SVELTA  
CUSTOM POS <sup>Ⓓ</sup>

---

**PRINT MODE** Printing mode.

Normal <sup>Ⓓ</sup> = enables printing in normal writing way  
Reverse = enables printing rotated 180 degrees

---

**AUTOFEED** Setting of the Carriage Return character:

CR disabled <sup>Ⓓ</sup> = Carriage Return disabled  
CR enabled = Carriage Return enabled

The parameter is printed on setup report only if the parameter "Printer emulation" is set on "CUSTOM POS".

---

**CODE TABLE** Identifier number of the character code table to use.

See [paragraph 9.11](#) to learn about the character tables corresponding to the identification numbers set with this parameter.

The character tables set with this parameter are the same set with the command 0x1B 0x74 (refer to the commands manual of the device).

The numeric value of the identifier is made up with the following two parameters for the setting of two digits for the tens and the units:

---

	Setting the digit for tens:				
CODE TABLE [num x 10]	0 <sup>Ⓓ</sup>	2	4		
	1	3	5		

---

	Setting the digit for units:				
CODE TABLE [num x 1]	0 <sup>Ⓓ</sup>	2	4	6	8
	1	3	5	7	9

---

**CHINESE FONT** Setting of the Chinese font:

Disabled <sup>Ⓓ</sup> = Disables the use of the Chinese extended font GB18030-2000  
Enabled = Enables the use of the Chinese extended font GB18030-2000

When the Chinese font is enabled, the selection of the character code table is suspended (parameter "Code table"). When the Chinese fonts is disabled, it returns the character code table previously in use (parameter "Code table").

---



---

**CHARS / INCH**

Font selection (CPI = Characters Per Inch):

A = 11 cpi, B = 15 cpi  
A = 15 cpi, B = 20 cpi <sup>D</sup>  
A = 20 cpi, B = 15 cpi

The parameter is printed on setup report only if the parameter "Printer emulation" is set on "CUSTOM POS".

---

**SPEED / QUALITY**

Setting of speed and printing quality.

Normal <sup>D</sup>  
High Quality  
High Speed

---

**PRINT WIDTH**

Width of printing area:

18 mm	34 mm	50 mm	66 mm
20 mm	36 mm	52 mm	68 mm
22 mm	38 mm	54 mm	70 mm
24 mm	40 mm	56 mm	72 mm
26 mm	42 mm	58 mm	74 mm
28 mm	44 mm	60 mm	76 mm
30 mm	46 mm	62 mm	78 mm
32 mm	48 mm	64 mm	80 mm <sup>D</sup>

---

**PAPER THRESHOLD**

Threshold value (in percent) for the recognition of the presence of paper by the paper presence sensor.

30% 70%  
40% <sup>D</sup> 80%  
50% 90%  
60%

---

**AUTOSTOP AT BLACK MARK**

This parameter enables/disables the automatic printing interruption when a black mark is detected:

Disabled <sup>D</sup> = Automatic printing interruption disabled  
Enabled = Automatic printing interruption enabled

If parameter "Black mark position" is set on "Disabled", this parameter has no effect on device configuration and it is not printed on setup report.

---

**TICKET LOCKING**

This parameter enables/disables the block of the paper inside the device where the ticket is not cut with the autocutter, but is presented for the manual tear off by the user:

Disabled <sup>D</sup> = paper block disabled  
Enabled = paper block enabled

If parameter "Black mark position" is set on "Disabled", this parameter has no effect on device configuration and it is not printed on setup report.

---



---

**TICKET MANAGEMENT**

This parameter allows the ticket management:

Disabled <sup>D</sup> = no check

Short Ticket = it is possible to manage tickets with length less than the distance between black mark sensor and printing line

Check First = before printing, the device checks the integrity of the first ticket

---

**PRINTHEAD TEST  
POWERON**

Setting of the performing of the print head test:

Disabled <sup>D</sup> = the test is performed only during the printing of the setup report

Enabled = the test is performed at each power on

---

**CUT RECOVERY**

Setting of the paper recovery after the ticket cut:

After cut <sup>D</sup> = the paper recovery is performed immediately after the ticket cut

Before printing = the paper recovery is performed just before printing the next ticket

This parameter is valid only for KPM180H 2, KPM180H 3, KPM180H 4, KPM180H 5, KPM180H 6, TK180 CUT 1, TK180 CUT 2, TK180 CUT 3.

---

**CASING TYPE**

Type of device casing:

Plastic <sup>D</sup> = plastic casing

Metal = metallic casing

The parameter is printed on setup report and has effect on device configuration only for TK180 MET 1, TK180 CUT 1, TK180 CUT 2, TK180 CUT 3, TK180 MET 2, TK180 MET 3, TK180 PLAS 1, TK180 PLAS 2, TK180 PLAS 3.

---

**PRINT DENSITY**

Adjusting the printing density:

-50% -12% +25%

-37% 0 <sup>D</sup> +37%

-25% +12% +50%

The print quality is strongly influenced by the type of chemical treatment and the type of storage to which the thermal paper has been subjected, as well as by the weight of the same. It may therefore necessary to act on this parameter to obtain the desired print quality.

---

## 6.8 Alignment parameters

The parameters marked with the symbol <sup>D</sup> are the default values.

Settings remain active even after the device has been turned off and they are stored in non-volatile me.

### BLACK MARK POSITION

Position of the alignment black mark and choice of appropriate black mark sensor (see [chapter 7](#)):

- Disabled = the black mark alignment is not performed
- Top = the black mark position is detected by the top sensor (reflection)
- Bottom = the black mark position is detected by the bottom sensor (reflection)
- Transparent <sup>D</sup> = the black mark is detected by the bottom sensor and the top sensor placed in front of (transparence)

### BLACK MARK THRESHOLD

Threshold value (in percent) for the recognition of the presence of black mark by the black mark sensor:

- 30%    70%
- 40% <sup>D</sup>    80%
- 50%    90%
- 60%

If parameter "Black mark position" is set on "Disabled", this parameter has no effect on device configuration and it is not printed on setup report.

### BLACK MARK DISTANCE

"Black mark distance" is the minimum distance (in millimetres) between the upper edge of ticket and the black mark (see [chapter 7](#)).

The numeric value of the distance is made up with the following four parameters for the setting of three digits (two for the integer part of the number, one for the decimal part and of the sign):

	Sign setting:				
BLACK MARK DISTANCE SIGN	+ <sup>D</sup> =	positive distance			
	- =	negative distance			

	Setting the digit for tens:				
BLACK MARK DISTANCE [mm x 10]	0 <sup>D</sup>	2	4	6	8
	1	3	5	7	9

	Setting the digit for units:				
BLACK MARK DISTANCE [mm x 1]	0 <sup>D</sup>	2	4	6	8
	1	3	5	7	9

	Setting the digit for decimals:				
BLACK MARK DISTANCE [mm x .1]	0 <sup>D</sup>	2	4	6	8
	1	3	5	7	9



---

For example, to set the black mark distance to 15 mm, modify the parameters as follows:

Black mark distance sign = +  
Black mark distance [mm x 10] = 1  
Black mark distance [mm x 1] = 5  
Black mark distance [mm x .1] = 0

If the "Black mark position" parameter is disabled, the parameters for the "Black mark distance" are not printed.

---

**BLACK MARK  
MIN. WIDTH**

This parameter set the minimum length of the black mark in order to avoid that other graphics present on the ticket can be detected as a black mark.

0 mm <sup>D</sup>	6 mm	12 mm	18 mm
1 mm	7 mm	13 mm	19 mm
2 mm	8 mm	14 mm	20 mm
3 mm	9 mm	15 mm	
4 mm	10 mm	16 mm	
5 mm	11 mm	17 mm	

If parameter "Black mark position" is set on "Disabled", this parameter has no effect on device configuration and it is not printed on setup report.

---





## 6.9 Hexadecimal dump

This function is used for the diagnosis of the characters received from the communications port. Characters are printed as hexadecimal code and the corresponding ASCII code (see below). Each line is preceded by a counter in hexadecimal that indicates the number of bytes received.

During the startup, if you hold down the LF LINE FEED key, the device enters the self-test routine and print the setup report. The device remains in standby until a key is pressed or characters are received through the communication port (Hexadecimal dump mode). For each character sent, the ticket shows the hexadecimal value and the ASCII codes (if the characters are underlined, the receive buffer is full). Shown below is an example of a Hexadecimal dump:

HEXADECIMAL DUMP									
31	32	33	34	35	...	12345	...		
39	30	31	32	33	...	90123	...		
37	38	39	75	69	...	789ui	...		
68	6B	6A	73	64	...	hkjsd	...		
73	64	66	6B	6A	...	sdfkj	...		
66	73	64	66	6B	...	fsdfk	...		
65	69	6F	79	75	...	eioyu	...		
6F	72	69	75	77	...	oriuw	...		
6F	75	77	65	72	...	ouwer	...		
77	65	72	69	6F	...	werio	...		
72	69	6F	75	77	...	riouw	...		
6B	6C	73	64	66	...	kl sdf	...		
64	66	6B	73	64	...	dfksd	...		
73	64	66	6B	6A	...	sdfkj	...		
66	6B	F2	6A	73	...	fk>j	...		
6A	6B	6C	68			jklh			





## 7 ALIGNMENT

The device is provided with sensors for the use of alignment black mark in order to handle:

- roll of tickets with pre-printed fields and a fixed length;
- Fan-fold of tickets with pre-printed fields and a fixed length.

The alignment black mark may be formed by:

- a black mark printed on paper (see [paragraph 9.10](#));
- a hole between two tickets (see [paragraph 9.10](#)).

All alignment sensors are “reflection” sensors: this kind of sensor emits a band of light and detects the quantity of light reflected to it. The presence of the black mark is therefore detected by the amount of light that returns to the sensor, considering that the light is reflected by the white paper and absorbed by the black mark.

To use tickets with holes, it is possible to use the same sensors as “transparence” sensors, coupled two by two: a beam of light is emitted by the transmitter sensor and the quantity of light which reaches the opposite receiver sensor is detected. The presence of the hole is detected evaluating the amount of light that arrives to the opposite sensor, considering that the paper doesn't allow the beam of light to reach the receiver, whereas a hole lets the light to reach the receiver.

The following paragraphs show how to correctly set the configuration parameters of device in order to assure the alignment.

## 7.1 Enable alignment

The device is provided with the two following sensors for alignment (see figure):

- SENSOR 1, a mobile sensor placed on the lower flat,
- SENSOR 2, a mobile sensor placed on the upper flat.

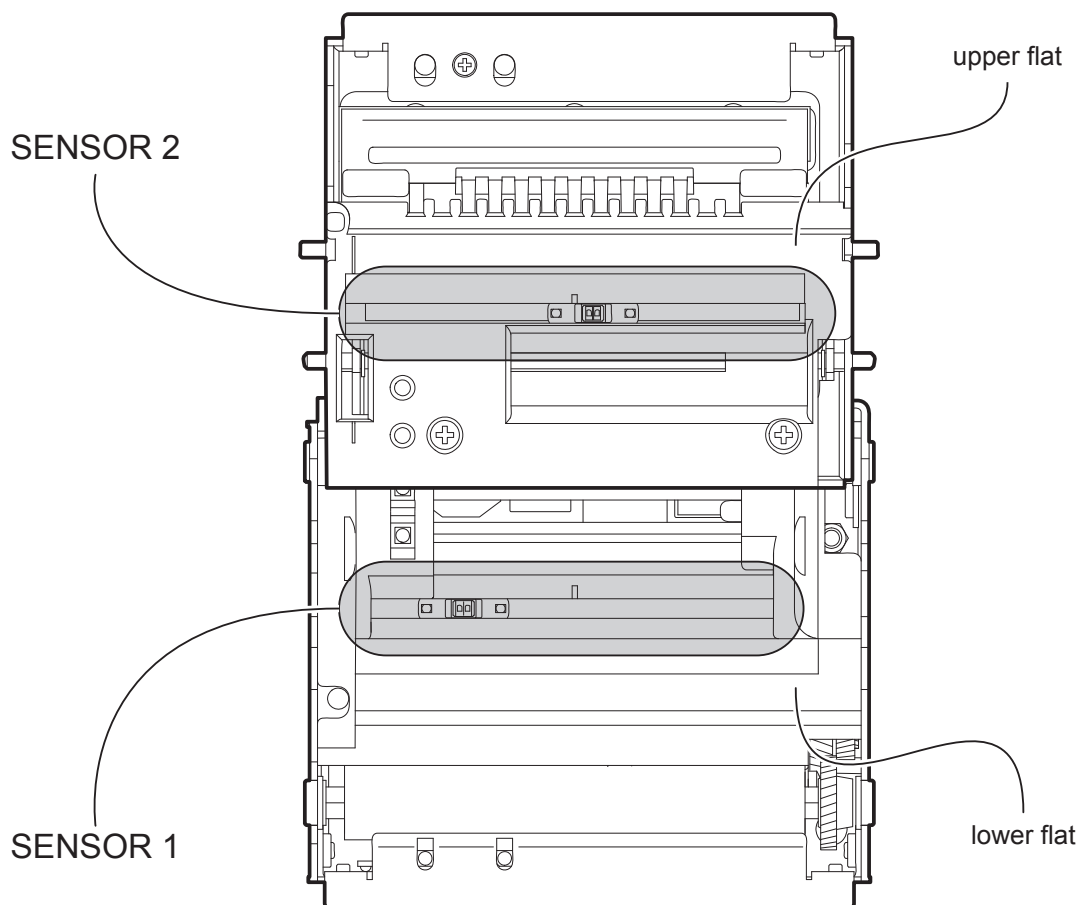

To guarantee the alignment, it is necessary to correctly choose the sensor to use for the black mark detection depending on the type of black mark and its location on the ticket.

To do this, you must enable the parameter “Black mark position” during the setup procedure (see [chapter 6](#)) and set the correct value of this parameter as described in the following table.

SENSOR USED	VALUE OF THE “BLACK MARK POSITION” PARAMETER	USING MODE OF SENSORS	BLACK MARK TYPE
-	Disabled	-	Alignment disabled
1	Bottom	Reflection	Black mark printed on the non-thermal side of paper
2	Top	Reflection	Black mark printed on the thermal side of paper
1 + 2	Transparent	Transparence	Hole between tickets



The following figures show the usable format of paper and the corresponding sensors used for alignment. For ease of understanding, the image shows the two flats represented in the same plane. For some models, only the internal printer group is represented.

**Paper with black mark on the non-thermal side**

**Paper with black mark on the thermal side**

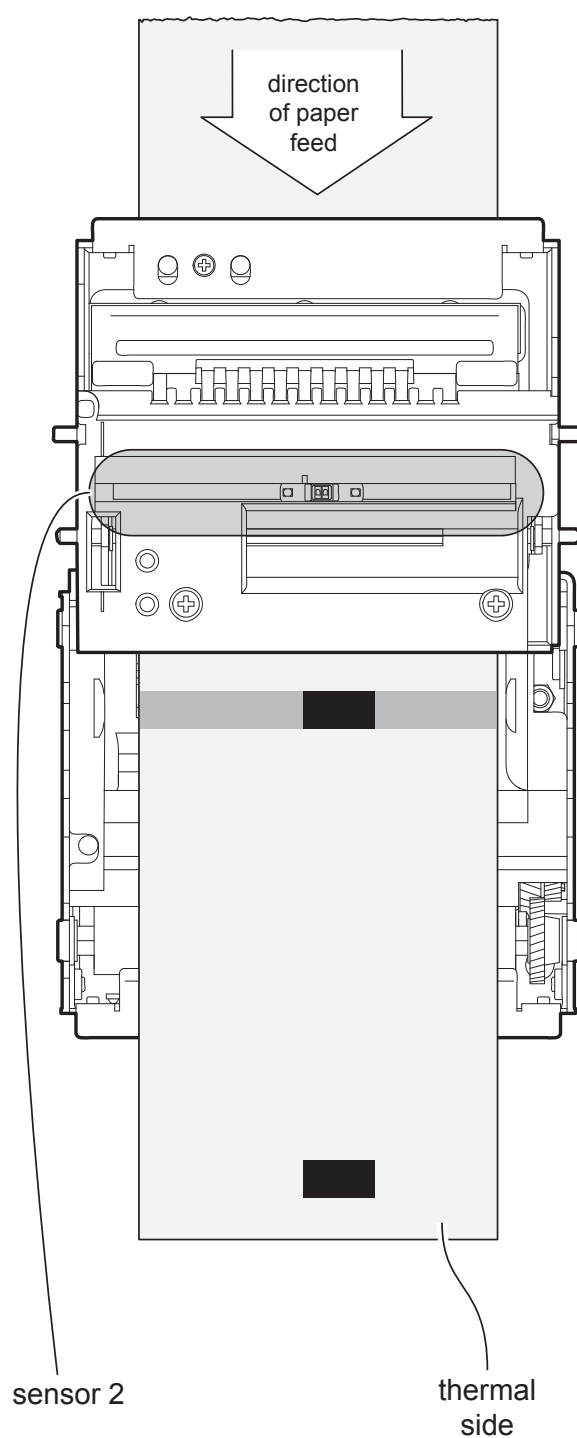
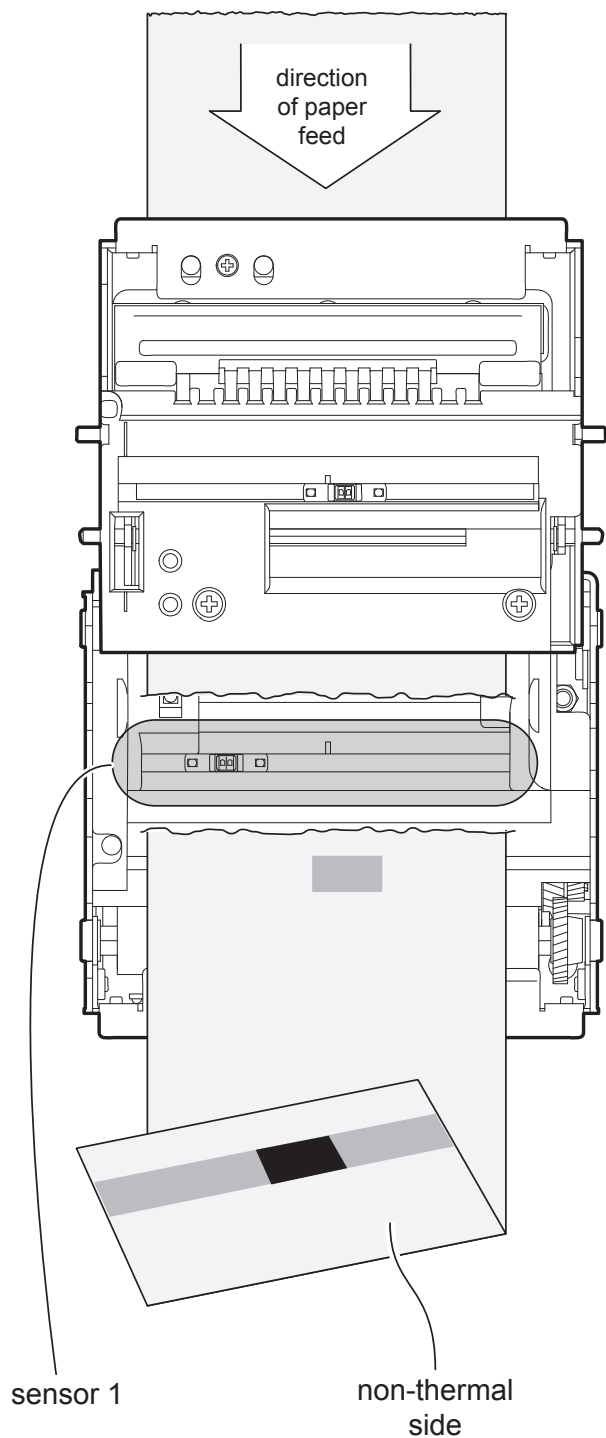



**Tickets with hole**

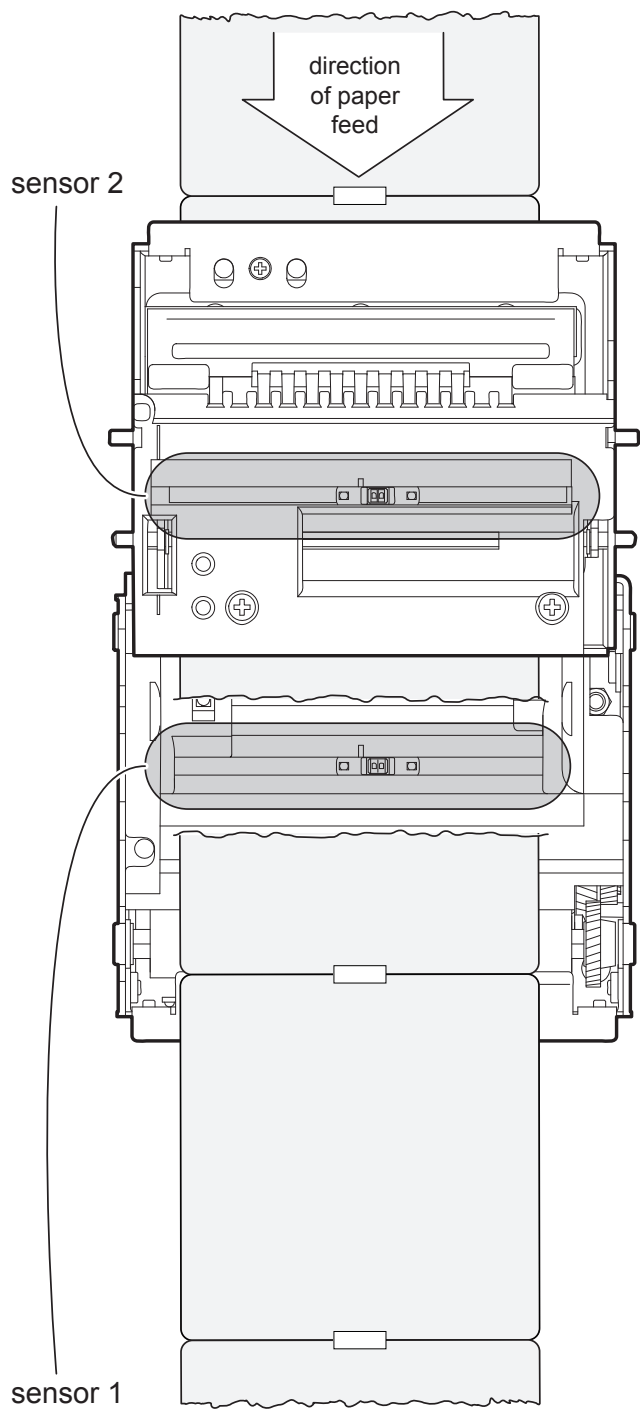

## 7.2 Calibration

The sensor calibration occurs automatically and consists in adjusting the quantity of light emitted to match the degree of whiteness of the paper used and the degree of black of the mark printed on paper.

The device automatically performs the self-calibration during the setup procedure only if the “Black mark position” parameter is set to a value other than “Disabled” (see [chapter 6](#)).

When self-calibration starts, the device performs some paper feeds and then it prints the calibration result and the value of the PWM duty-cycle of the alignment sensor driver so that it can be perform an optimal black mark detection:

```
Autosetting black mark : OK
PWM Duty Cycle : 85.3%
```

The “Autosetting black mark” parameter indicates the result of the self-calibration procedure; OK will appear if it has been successful, NOT OK will appear if the procedure has failed.

After the printing of the procedure result, the device offers the execution of the function of paper characterization “Characterize Paper” and the change of the “Black mark threshold” parameter which represents the detection threshold of the black mark. Choosing the “Yes” value for the “Characterize Paper” parameter, the device prints a graphic representation (see following figures) of the outgoing voltage of the alignment sensor (expressed as a percentage) and the “Black mark threshold” value. This graphic representation is useful to set the most suitable value to assign to the “Black mark threshold” parameter and then to better identify the optimal threshold value which takes into account the variations of the signal and the small oscillations around zero.

The following figure shows an example of paper with the non-thermal paper printed with black marks: the outgoing voltage is constant while passing the white paper between two black marks and presents a peak at each black mark. In this case, the optimal value for the “Black mark threshold” parameter is placed about half of the peak (as shown in figure).

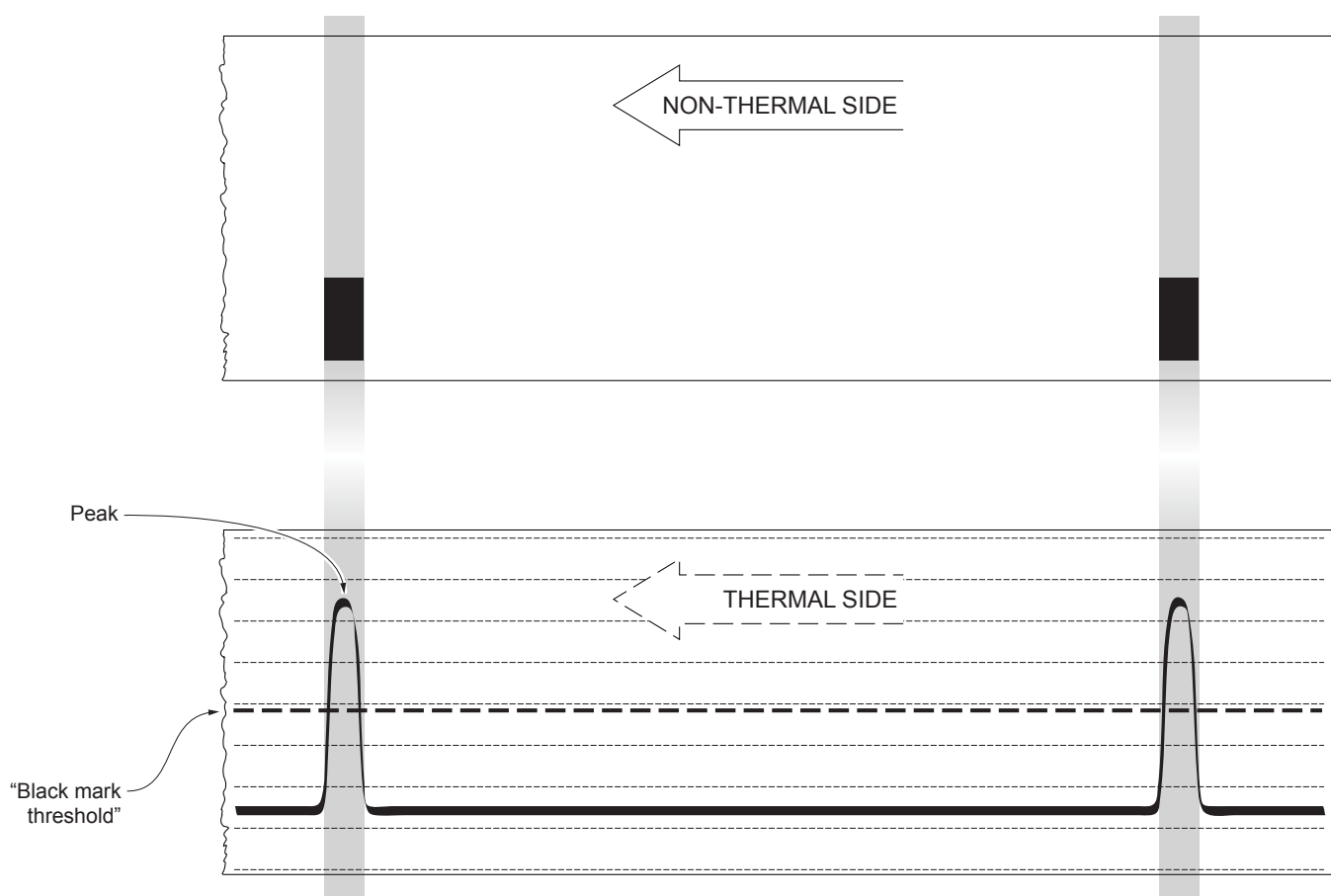



The following figure shows an example of paper with the non-thermal paper printed with black marks and other graphics (for example, a barcode): the outgoing voltage is constant while passing the white paper between two black marks, presents a peak at each black mark and presents some “noise” at each barcode.

In this case, the optimal value for the “Black mark threshold” parameter is located about halfway between the peak value and the maximum value of the “noise” (as shown in figure).

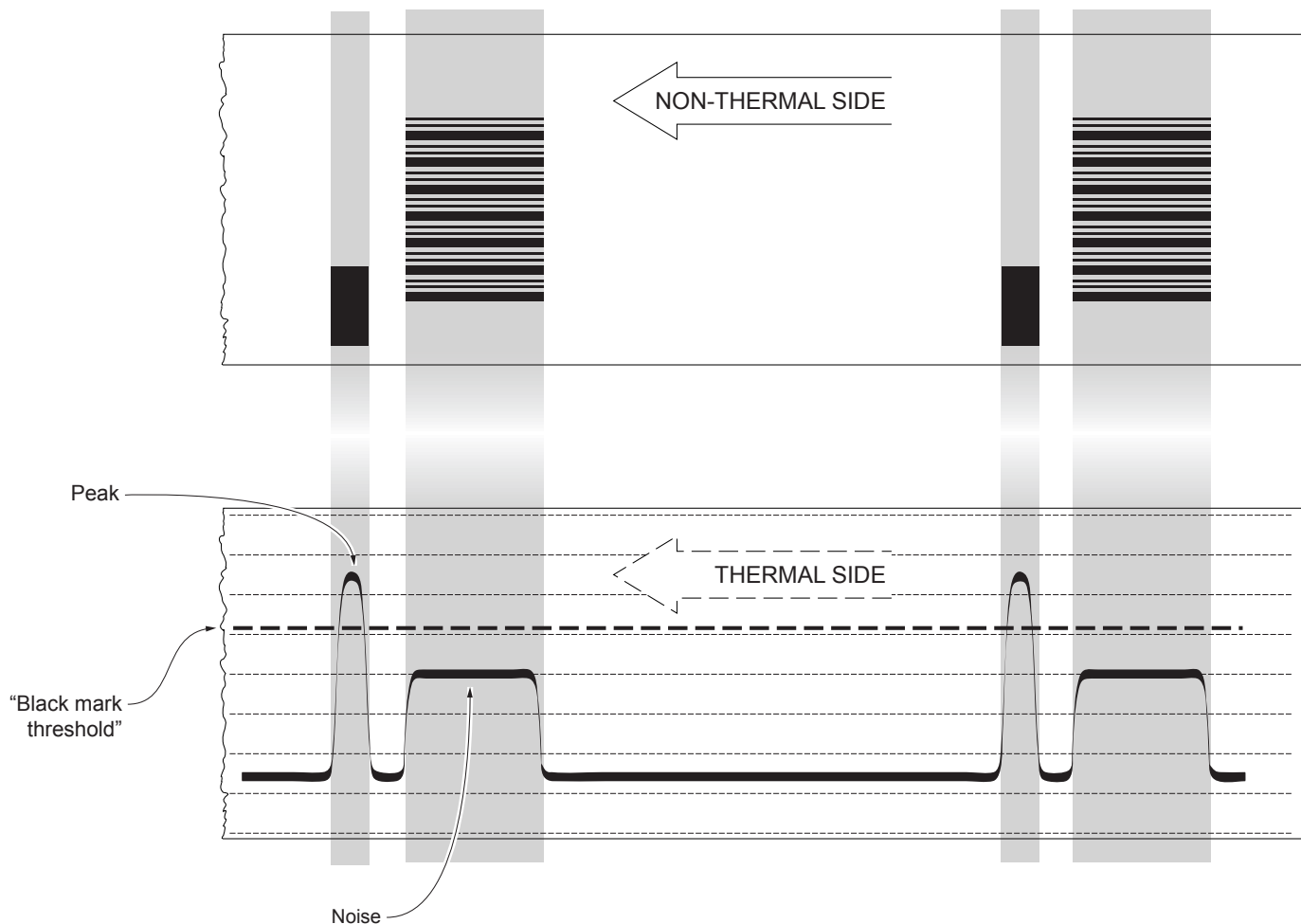

If the maximum value of “noise” read by the sensor is very close to the peak value, it might be difficult to place the value of the “Black mark threshold” at an intermediate point. In these cases, it is mandatory that the portion of paper between the point of printing end and the front of black mark is completely white (no graphics). In this way, the only next graphic detected by the sensor for alignment after the printing end will be the black mark.



The following figure shows an example of paper with holes: the outgoing voltage is constant while passing the paper between two holes and presents a variation at each hole. In this case, the optimal value for the “Black mark threshold” parameter is placed about half of the variation.

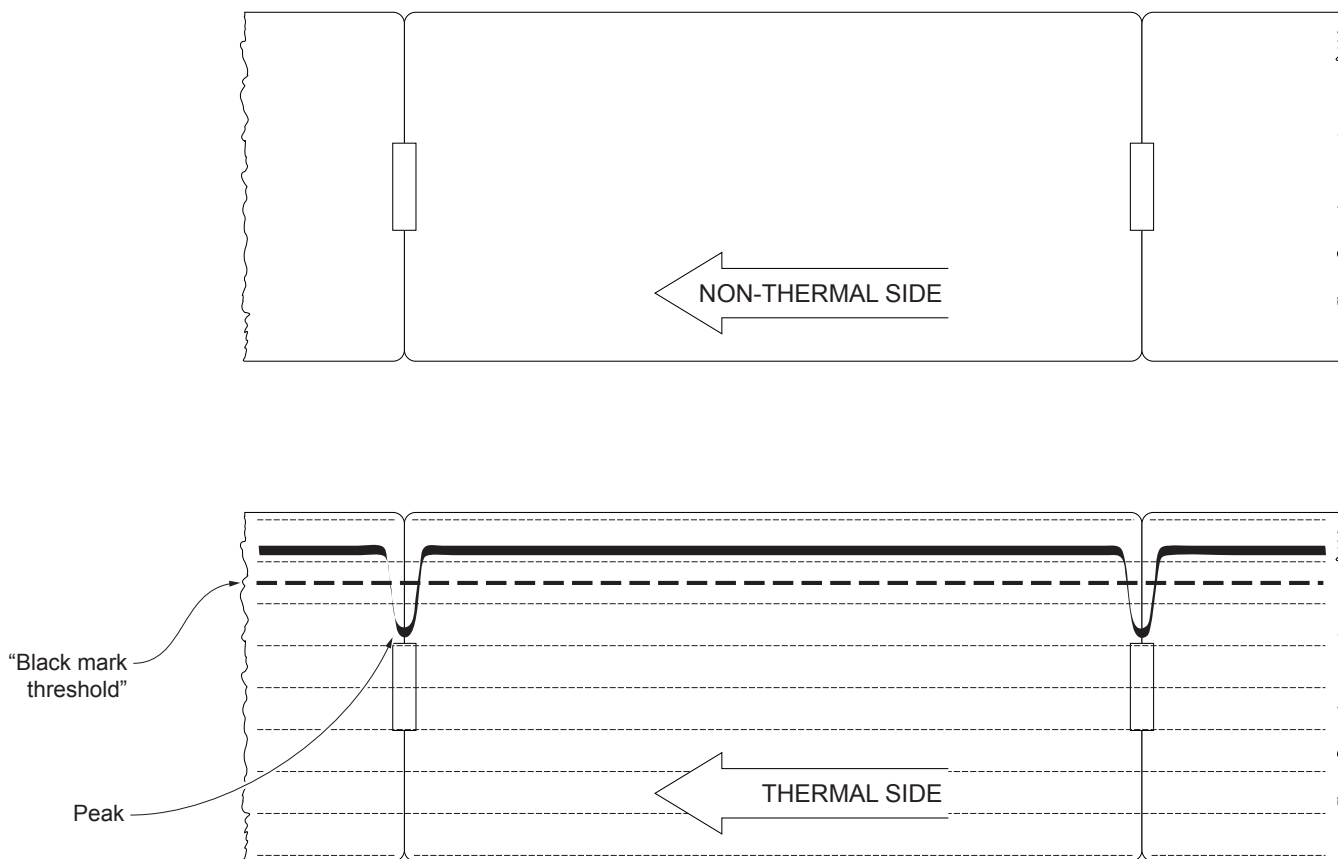

## 7.3 Alignment parameters

The “alignment point” is defined as the position inside the ticket to use for the black mark alignment. The distance between the black mark edge and the alignment point is defined as “Black mark distance”.

Referring to the front of the black mark, the value of “Black mark distance” value varies from -5 mm minimum and 99.9 mm maximum.

If the “Black mark distance” value is set to 0, the alignment point is set at the beginning of the black mark.

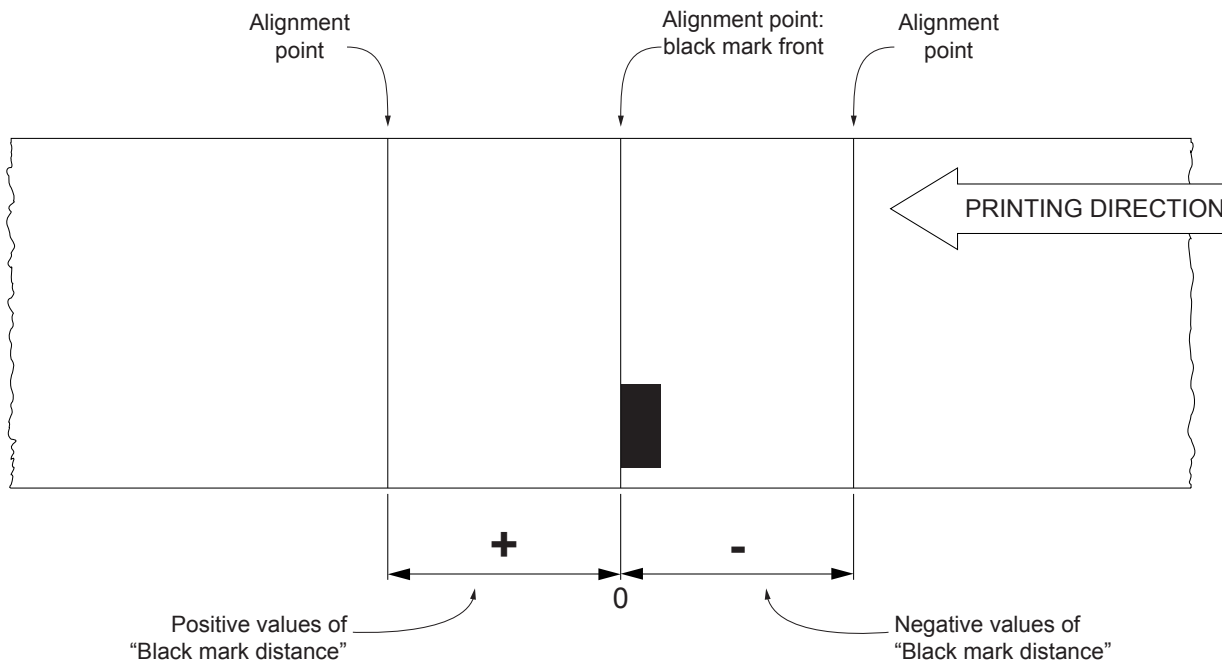

The following figure shows an example of paper with alignment point set by a positive value of “Black mark distance” (“Black mark distance” = + A):

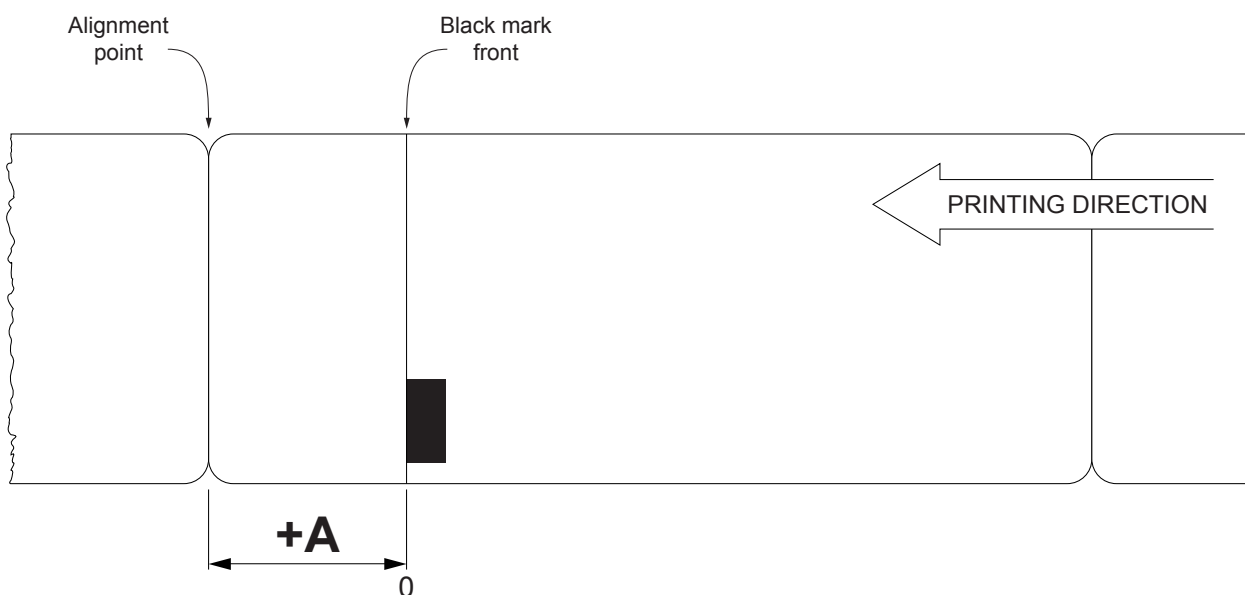



To set a negative value of the “Black mark distance” parameter is useful in cases where the alignment point refers to the black mark printed on the previous ticket or where the desired cutting line is placed in the middle of the alignment black mark (for example, for paper with holes or gap). In the following images, the value of “Black mark distance” parameter is set to  $-A$ .

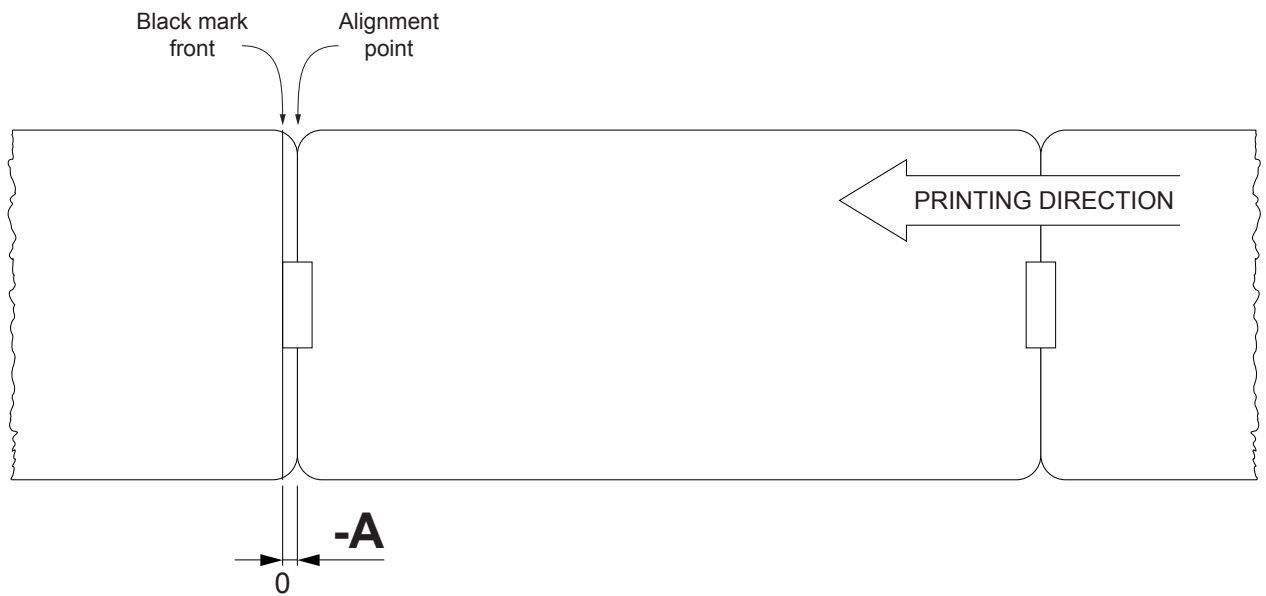
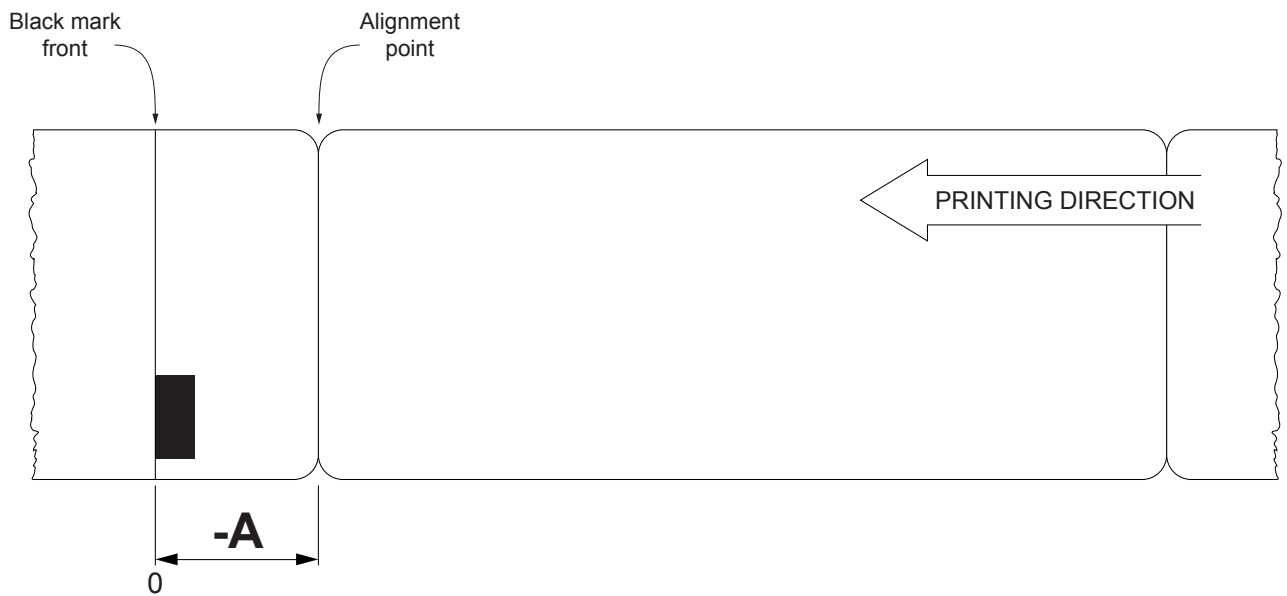



The following figures show the simplified sections of the device models with the paper path and the distances (in millimeters) between the alignment sensor, the print head, autocutter (if present) and paper out mouth.

**KPM180H 1**  
**TK180 MET 1, TK180 MET 2, TK180 MET 3,**  
**TK180 PLAS 1, TK180 PLAS 2, TK180 PLAS 3**

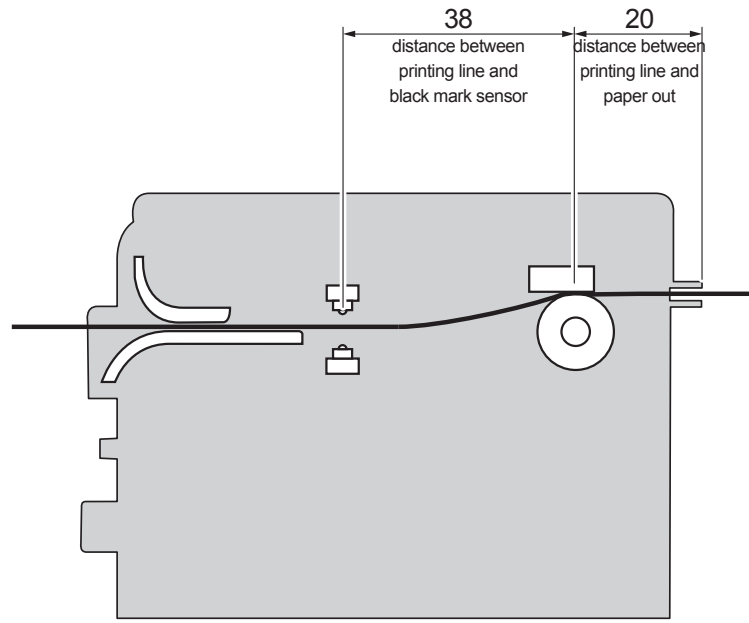

**KPM180H 2, KPM180H 3, KPM180H 4, KPM180H 5, KPM180H 6**  
**TK180 CUT 1, TK180 CUT 2, TK180 CUT 3**

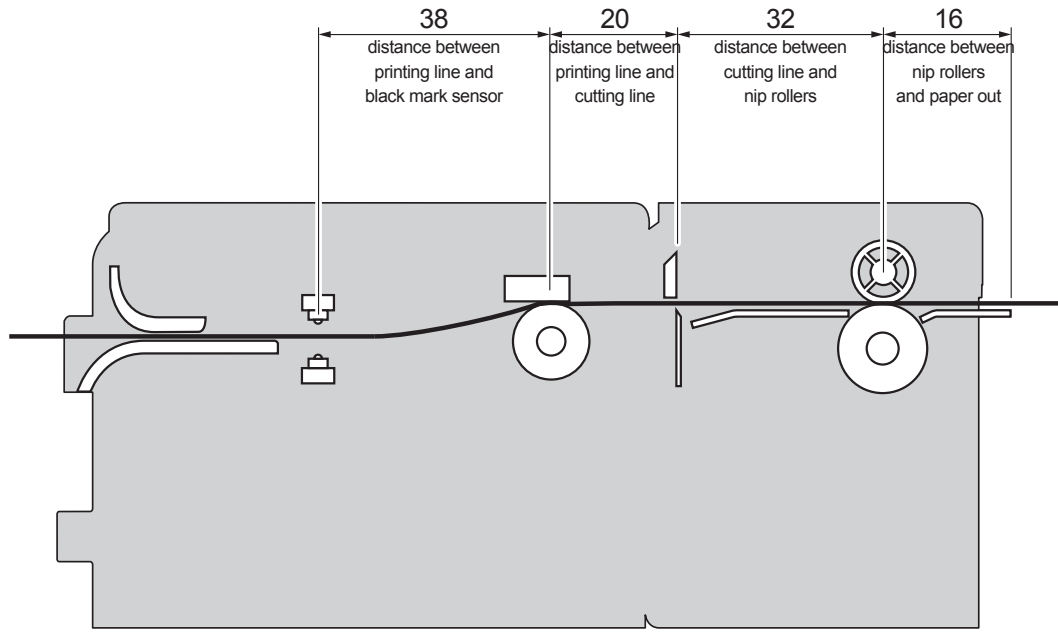

## **CUSTOM/POS emulation**

To define the alignment point you need to set the printer parameters that compose the numerical value of the “Black mark distance” parameter (see [paragraph 6.8](#)).

For example, to set a black mark distance of 15 mm between the black mark and the alignment point, the parameters must be set on the following values:

Black mark distance sign	:	+
Black mark distance [mm x 10]	:	1
Black mark distance [mm x 1]	:	5
Black mark distance [mm x .1]	:	0

The “Black mark distance” parameter, may be modified as follows:

- during the setup procedure of the device (see [paragraph 6.1](#));
- by modifying the "Setup.ini" file (see [paragraph 6.3](#));
- by using the 0x1D 0xE7 command (for more details, refer to the commands manual);
- by software (see [paragraph 6.2](#)).

## **SVELTA emulation**

The ticket features and the alignment parameters, may be modified as follows:

- by using the parameters of the <LHT> command (for more details, refer to the commands manual);
- by modifying the "Setup.ini" file (see [paragraph 6.3](#));
- by driver.

The following figure shows the some of parameters for alignment of the "Setup.ini" file:

- “Ticket X Dimension”
- “Ticket Y Dimension”
- “Black mark width”
- “Black mark distance”

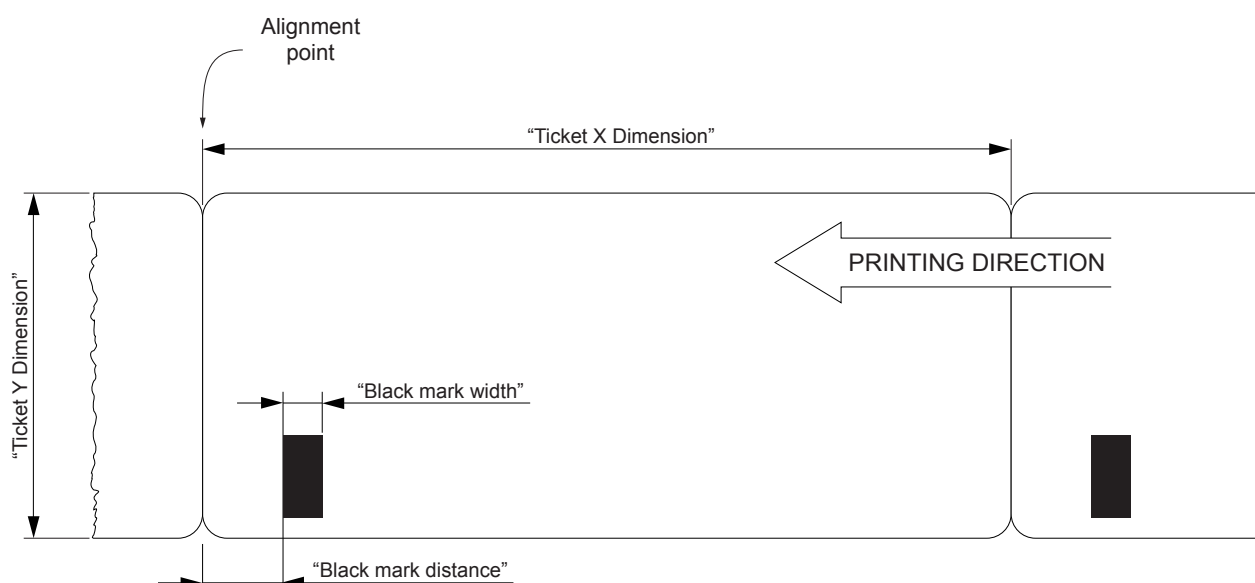

## 7.4 Printing area

In order to print ticket containing only one black mark and to not overlay printing to a black mark (that will make it useless for the next alignment), it is important to well calibrate:

- the length of the printing area of ticket according to the inter-black mark distance;
- the value for the paper recovery after a cut.

The following figure shows an example of tickets with “Black mark distance” set to 0.

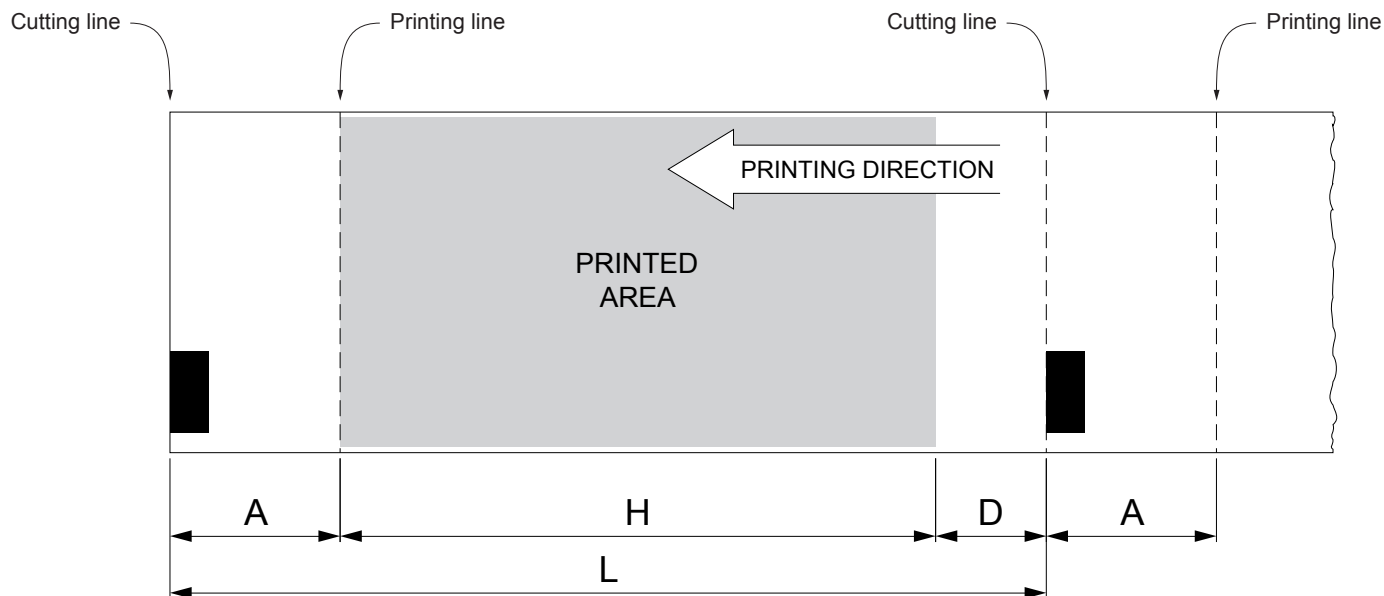

A “Non-printable area” of 1 mm generated from:

“Distance between autocutter/print head”- “Value for the paper recovery after a cut”

where:

“Distance between autocutter/print head” = 20 mm (fixed distance)

“Value for the paper recovery after a cut”= 19 mm

For models KPM180H 1, TK180 MET 1, TK180 MET 2, TK180 MET 3, TK180 PLAS 1, TK180 PLAS 2, TK180 PLAS 3, the distance A is fixed.

For models KPM180H 2, KPM180H 3, KPM180H 4, KPM180H 5, KPM180H 6, TK180 CUT 1, TK180 CUT 2, TK180 CUT 3, use the command 0x1C 0xC1 in CUSTOM/POS emulation to set the “Value for the paper recovery after a cut” (see the commands manual).

H Distance between the first and the last print line, called “Height of the printing area”.

L Distance between an edge of the black mark and the next one, called “Inter-black mark distance”.

D Automatic feed for alignment at the next black mark.

To use all the black marks on paper, you must comply with the following equation:

$$H + A \leq L$$

The height of the printing area (H) can be increased to make no progress on alignment (D) but no further.



# 8 MAINTENANCE

## 8.1 Printer paper jam

In the following sequence of images, the procedure for solving the paper jam inside the printer is described. For some models, only the internal printer group is represented.

**1**

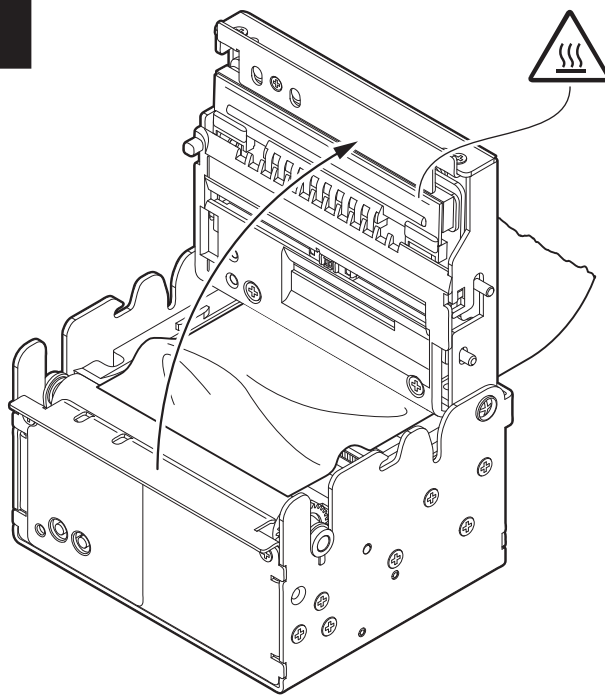

Open the device cover  
(see [paragraph 5.1](#))

**2**

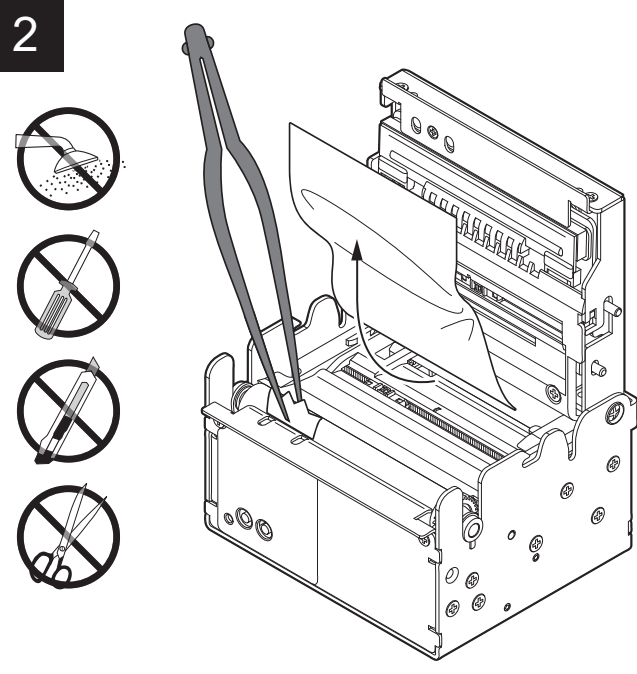

Remove the damaged paper and check the presence for paper scraps inside the device. Carefully remove all paper scraps. If necessary use tweezers.

**3**

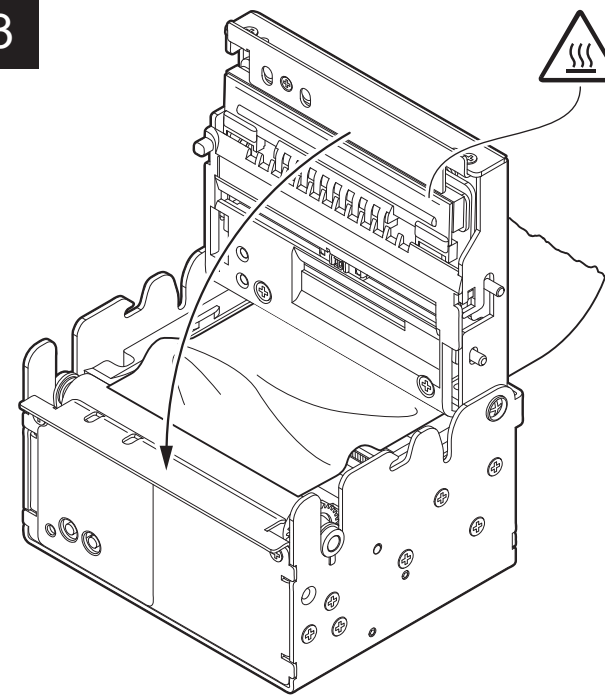

Close the device cover.

**4**

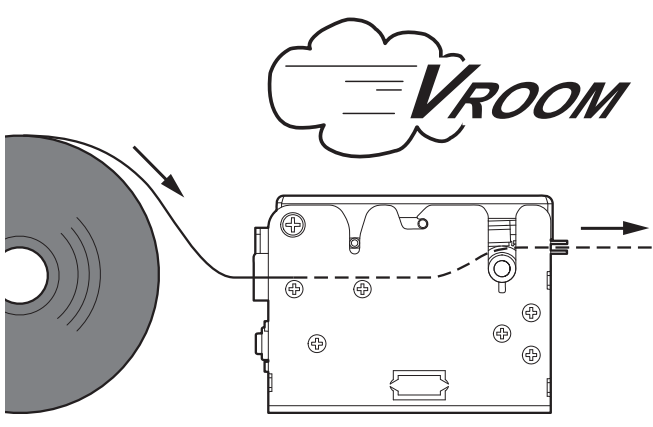

Insert the paper  
(see [paragraph 5.9](#))



## 8.2 Autocutter paper jam

KPM180H 2, KPM180H 3, KPM180H 4, KPM180H 5, KPM180H 6  
TK180 CUT 1, TK180 CUT 2, TK180 CUT 3

In the following sequence of images, the procedure for solving the paper jam inside the autocutter is described. For some models, only the internal printer group is represented.

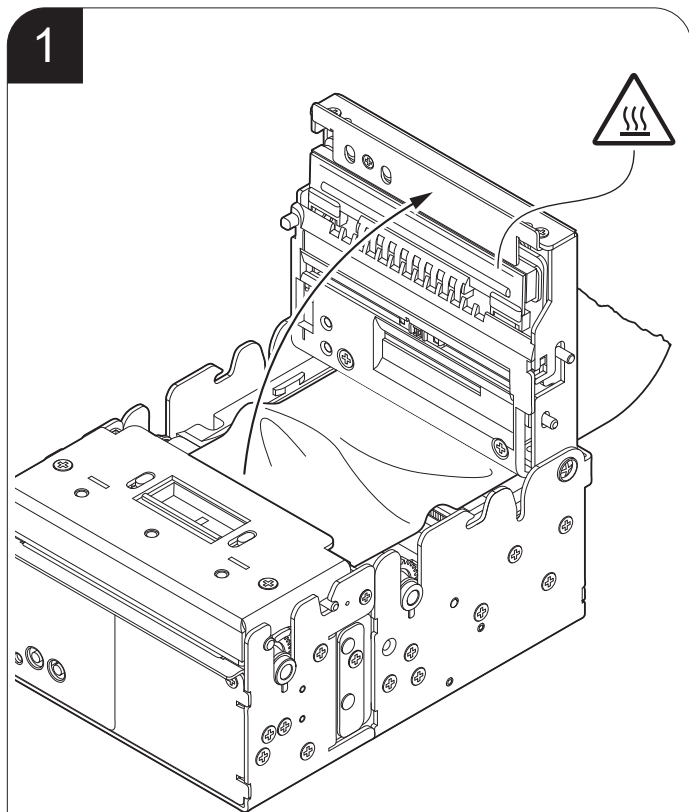

Open the device cover  
(see [paragraph 5.1](#))

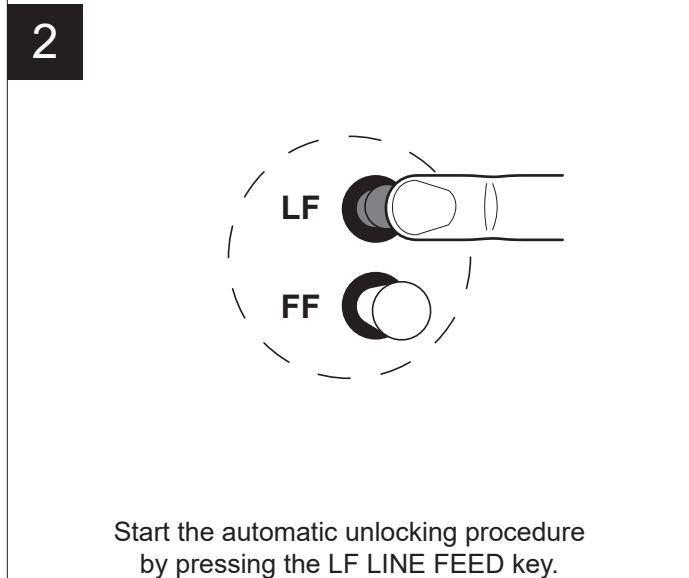

Start the automatic unlocking procedure  
by pressing the LF LINE FEED key.

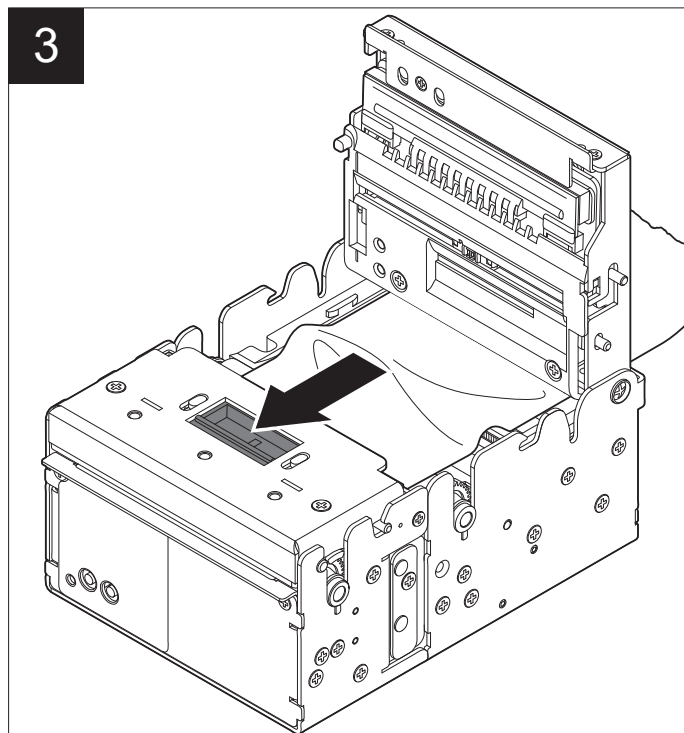

Push the release lever for the  
cover of the presenter group.

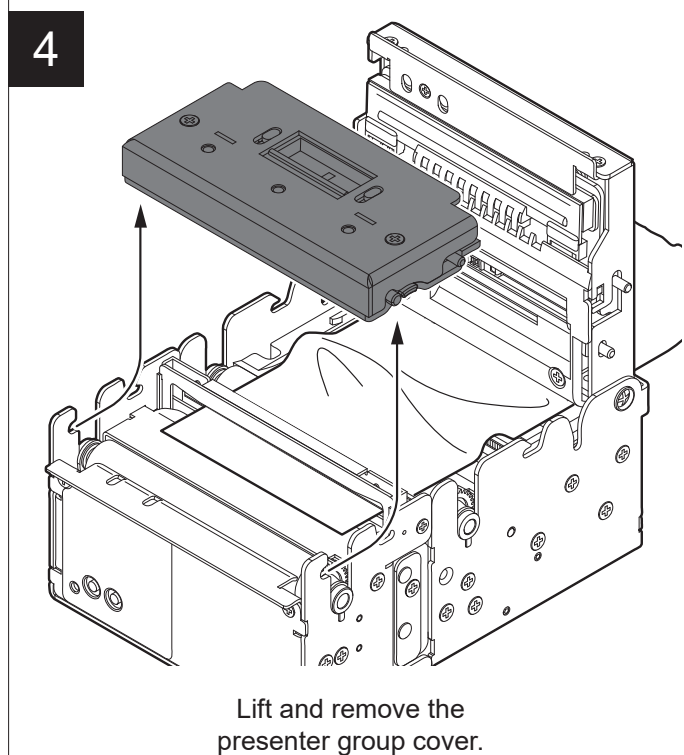

Lift and remove the  
presenter group cover.



5

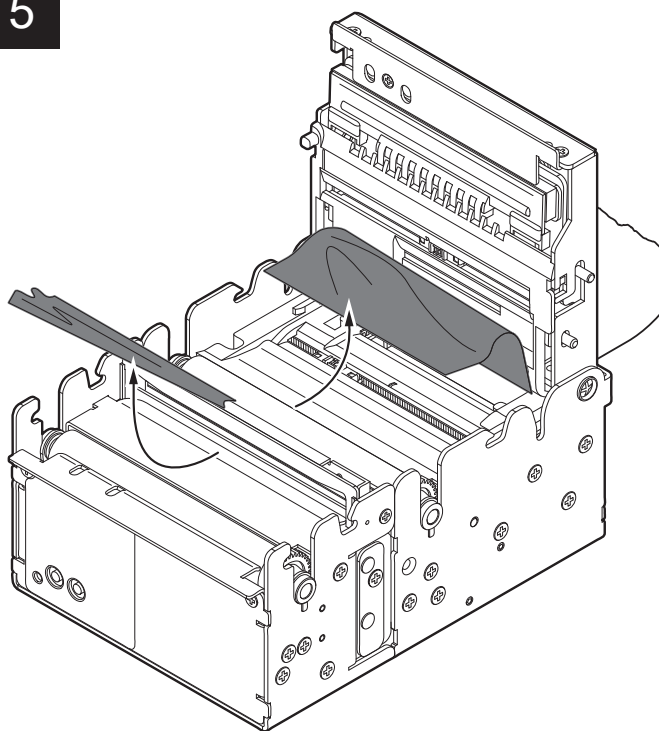

Try to remove the paper.  
If the operation fails, see the next point.

6

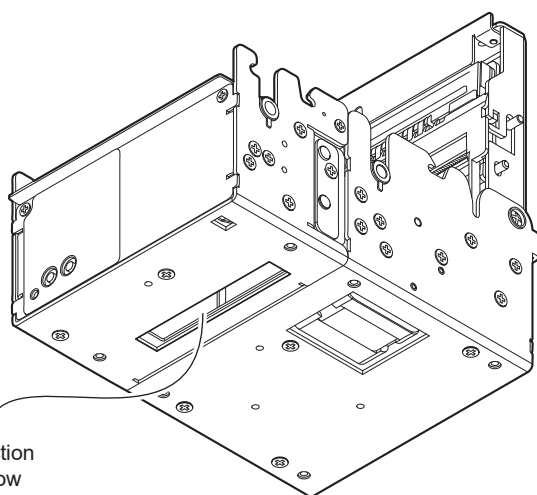

Locate the inspection window for the autocutter placed in the bottom of the presenter.

7

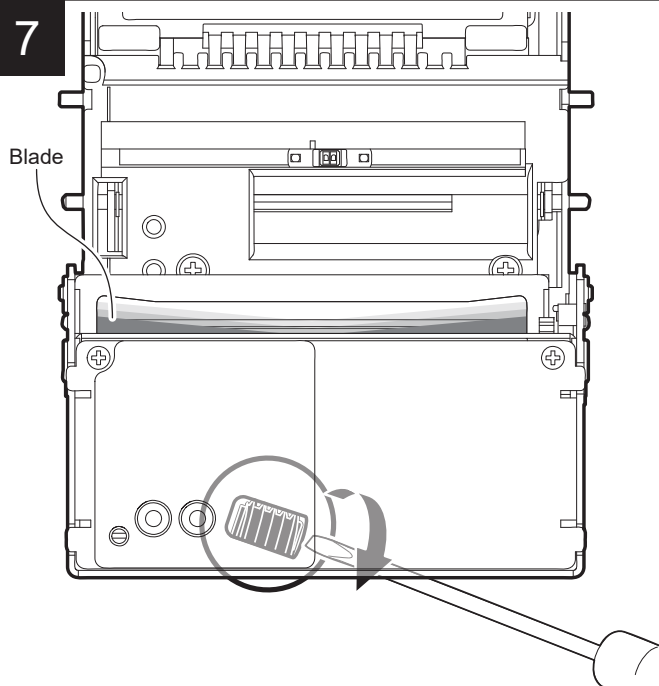

Insert a screwdriver in the inspector window and turn the worm screw to lower the autocutter blade.

8

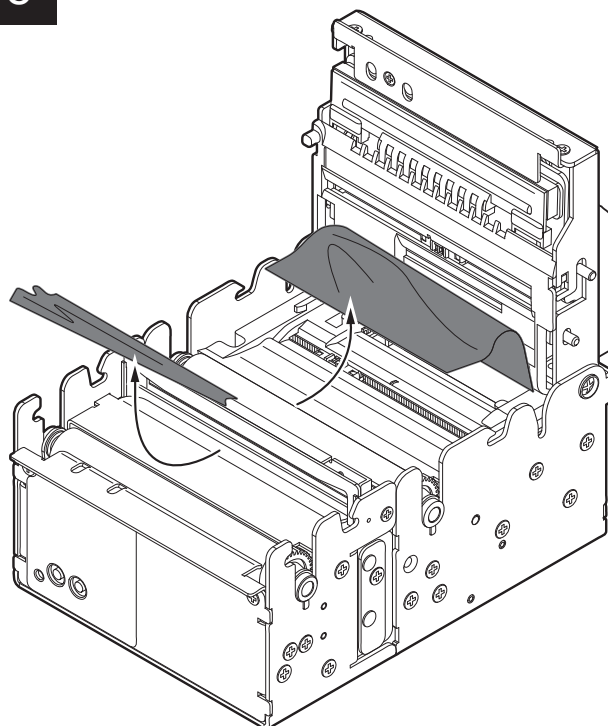

Remove the damaged paper and check the presence for paper scraps inside the printer; carefully remove all scraps of paper. If necessary, use tweezers.



## 8.3 Planning of cleaning operations

The regular cleaning of the device keeps the print quality and extends its life.

The following tables show the recommended planning for the cleaning operations. If you use the device in dusty environments, you must reduce the intervals between the cleaning operations.

For specific procedures, see [paragraph 8.4](#).

### **KPM180H 1, KPM180H 2, KPM180H 3**

### **TK180 MET 1, TK180 MET 2**

### **TK180 CUT 1, TK180 CUT 2**

### **TK180 PLAS 1, TK180 PLAS 2**

#### EVERY PAPER CHANGE

Printhead	Use isopropyl alcohol
-----------	-----------------------

Rollers	Use isopropyl alcohol
---------	-----------------------

#### EVERY 5 PAPER CHANGES

Autocutter (only if present)	Use compressed air
---------------------------------	--------------------

Paper path	Use compressed air or tweezers
------------	--------------------------------

Sensors	Use compressed air
---------	--------------------

#### EVERY 6 MONTHS OR AS NEEDED

Display (only if present)	Use compressed air or a soft cloth Don't use any ammonia-based product.
------------------------------	--

Case	Use compressed air or a soft cloth
------	------------------------------------



**KPM180H 4, KPM180H 5, KPM180H 6**  
**TK180 MET 3**  
**TK180 CUT 3**  
**TK180 PLAS 3**

EVERY PAPER CHANGE

Printhead Use isopropyl alcohol

Rollers Use isopropyl alcohol

EVERY 5 PAPER CHANGE

Paper path Use compressed air or tweezers

Sensors Use compressed air

Lower flat Use isopropyl alcohol

AS NEEDED

Autocutter (only if present) Use silicone oil  
Don't use alcohol or any aggressive solvent

Display (only if present) Use compressed air or a soft cloth  
Don't use any ammonia-based product.

Case Use compressed air or a soft cloth



# 8.4 Cleaning

For periodic cleaning of the device, see the instructions below (for some models, only the internal printer group is represented).

## Case

**1**

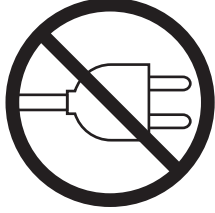

Disconnect the power supply cable.

**2**

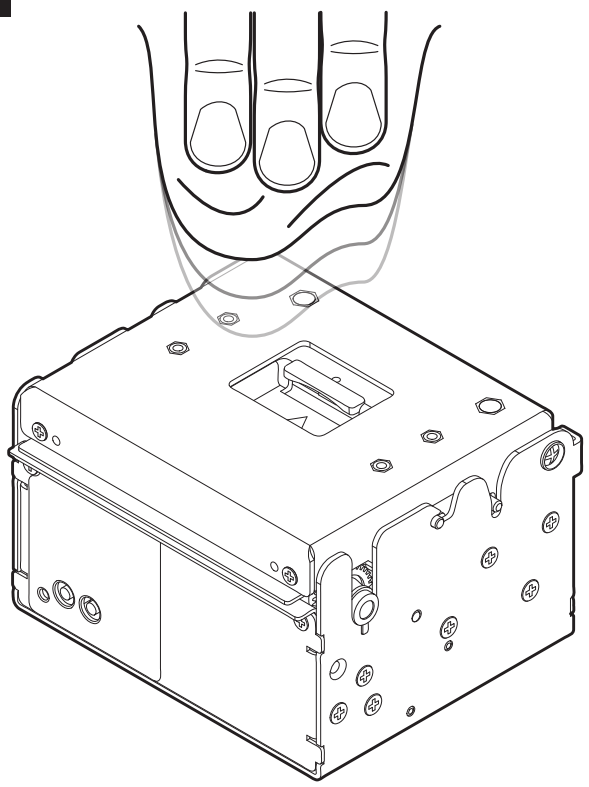

**ATTENTION:**  
Do not use alcohol, solvents, or hard brushes.  
Do not let water or other liquids get inside the device.

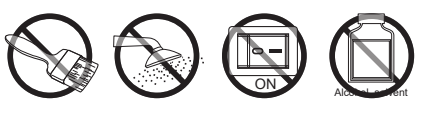

To clean the device,  
use compressed air or a soft cloth.

## Display

**1**

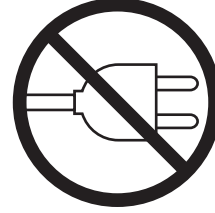

Disconnect the power supply cable.

**2**

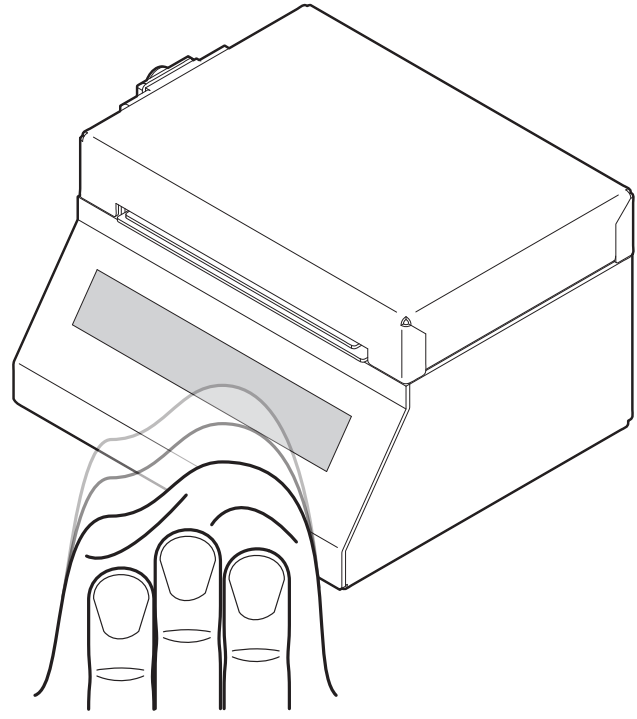

**ATTENTION:**  
Do not use alcohol, solvents, or hard brushes.  
Do not let water or other liquids get inside the machine.  
Do not use ammonia-based products .



To clean the display,  
use compressed air or a soft cloth.

## Printhead

1

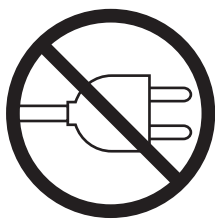

Disconnect the power supply cable and open the device cover (see [paragraph 5.1](#))

2

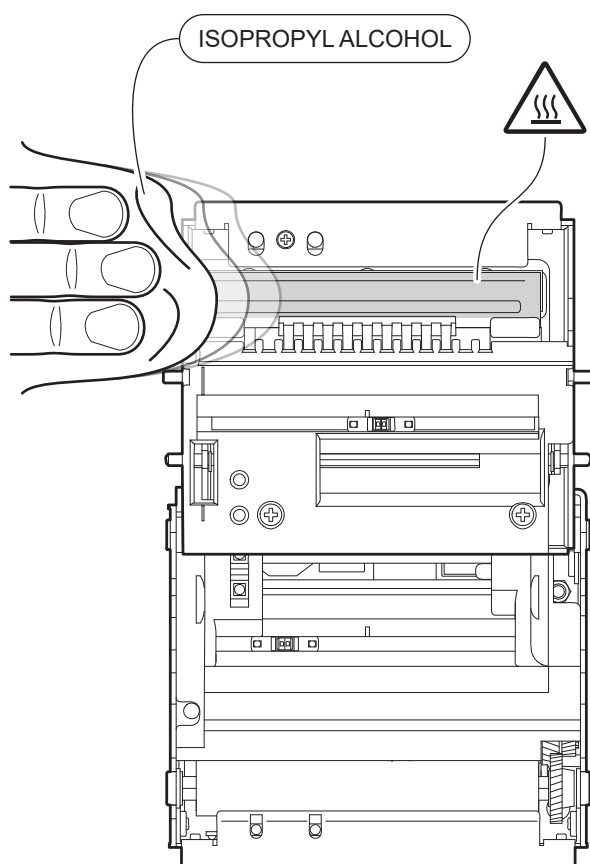

**ATTENTION:**

Do not use solvents, or hard brushes.  
Do not let water or other liquids get inside the machine.



Clean the printhead by using a non-abrasive cloth moistened with isopropyl alcohol.

## Platen roller

1

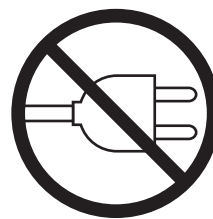

Disconnect the power supply cable and open the device cover (see [paragraph 5.1](#))

2

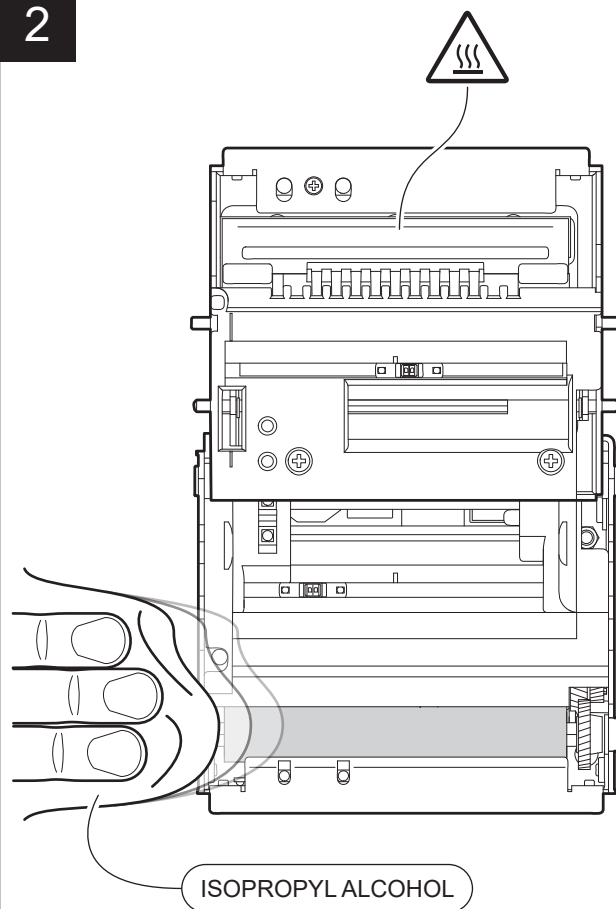

**ATTENTION:**

Do not use solvents, or hard brushes.  
Do not let water or other liquids get inside the machine.



Clean the platen roller by using a non-abrasive cloth moistened with isopropyl alcohol.

## Sensors

1

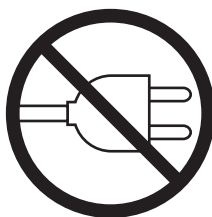

Disconnect the power supply cable and open the device cover (see [paragraph 5.1](#))

2

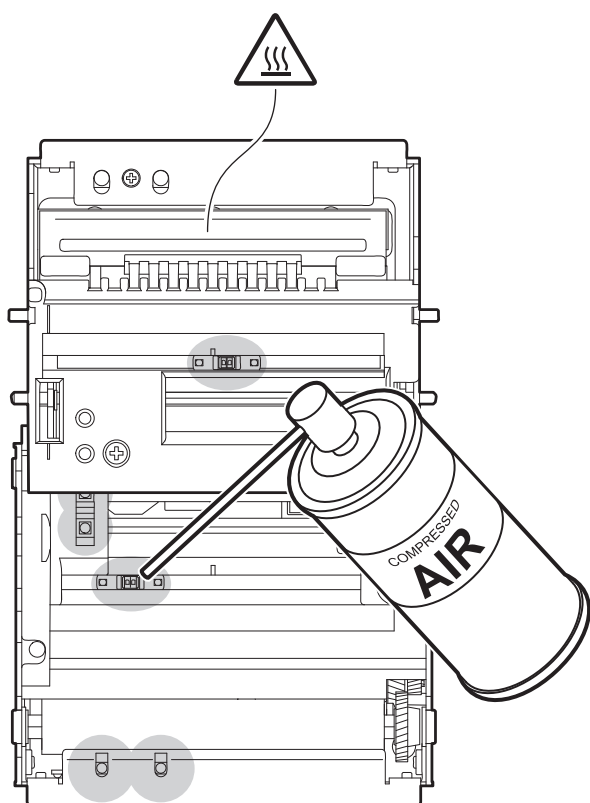

**ATTENTION:**

Do not use alcohol, solvents, or hard brushes.  
Do not let water or other liquids get inside the device.



Clean the device sensors by using compressed air.

## Paper path

1

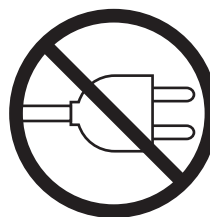

Disconnect the power supply cable and open the device cover (see [paragraph 5.1](#))

2

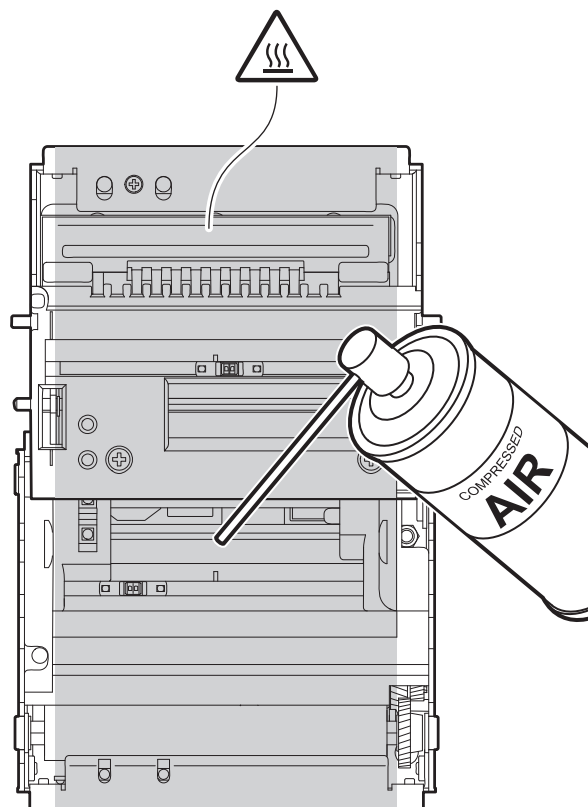

**ATTENTION:**

Do not use alcohol, solvents, or hard brushes.  
Do not let water or other liquids get inside the device.



Clean the area involved in the passage of paper by using compressed air.

## Lower flat

1

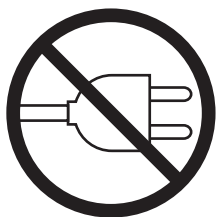

Disconnect the power supply cable and open the device cover (see [paragraph 5.1](#))

2

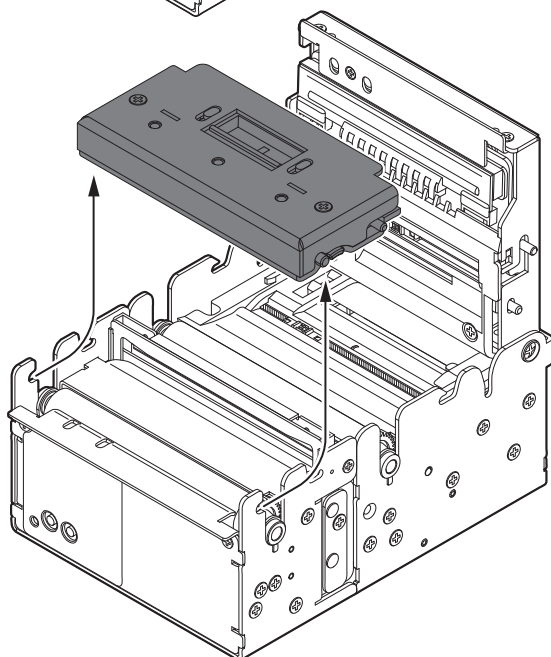
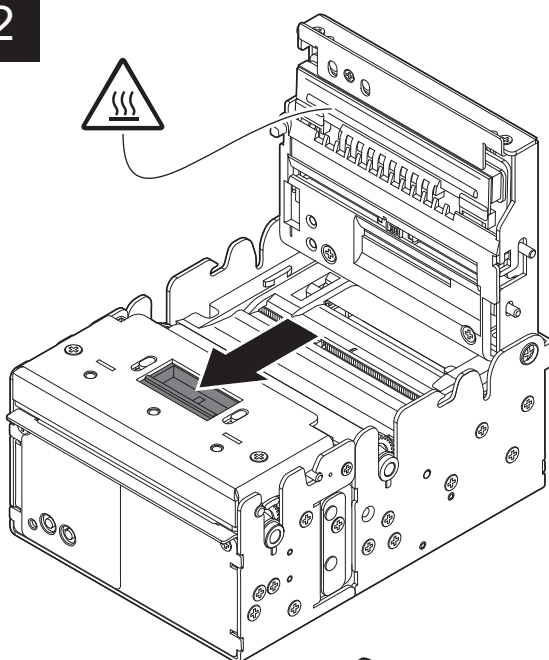

Push the release lever then lift and remove the presenter cover.

3

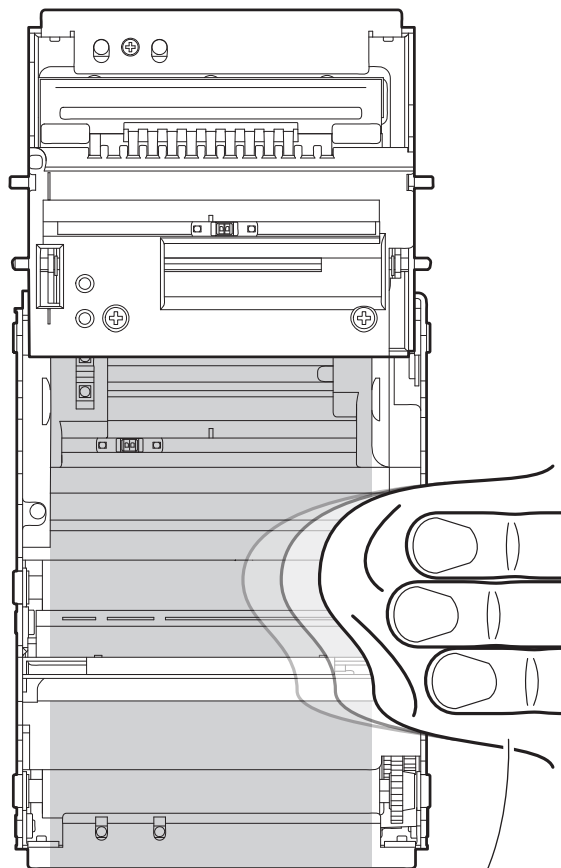

ISOPROPYL ALCOHOL

### ATTENTION:

Do not use alcohol, solvents, or hard brushes.  
Do not let water or other liquids get inside the device.



Clean the lower flat by using a non-abrasive cloth moistened with isopropyl alcohol.

## Autocutter (KPM180H 2, KPM180H 3, TK180 CUT 1, TK180 CUT 2)

1

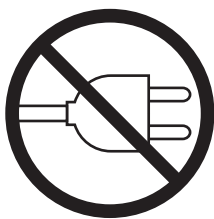

Disconnect the power supply cable and open the device cover (see paragraph 5.1)

2

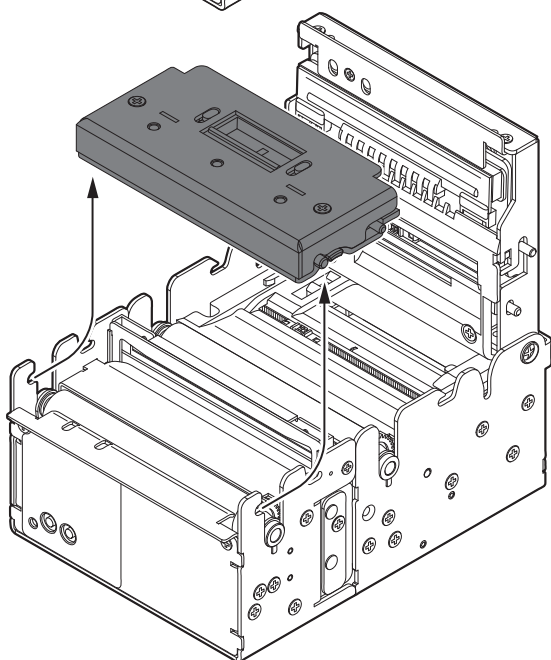
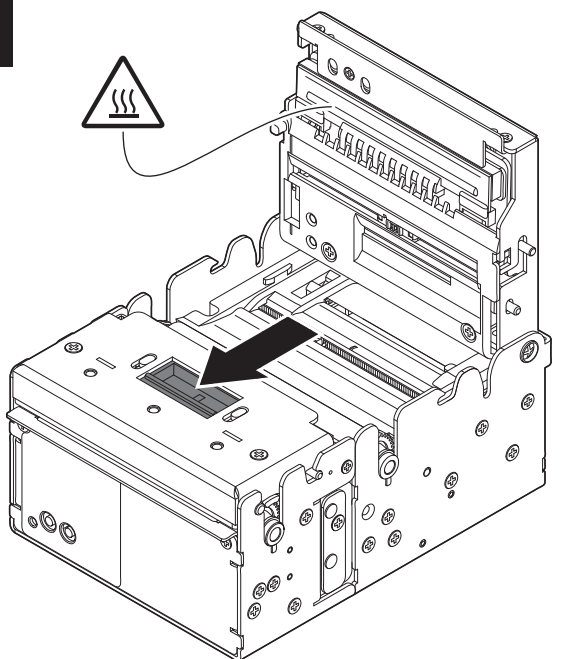

Push the release lever then lift and remove the presenter cover.

3

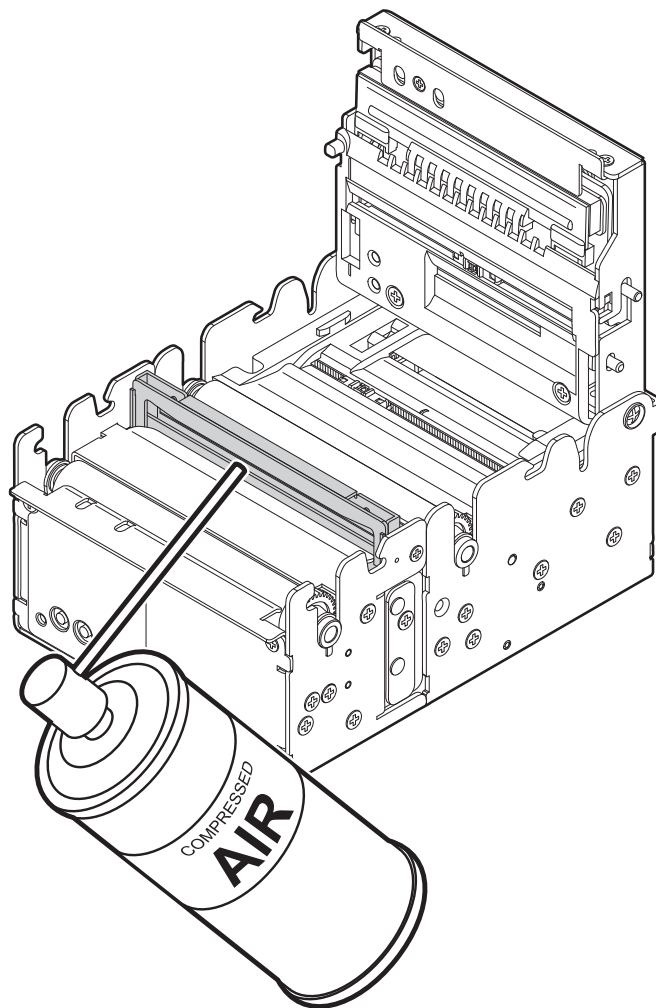

**ATTENTION:**  
Do not use alcohol, solvents, or hard brushes.  
Do not let water or other liquids get inside the device.



Clean the autocutter by using compressed air.



## Autocutter (KPM180H 4, KPM180H 5, KPM180H 6, TK180 MET 3, TK180 CUT 3)

1

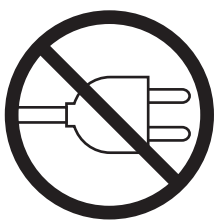

Disconnect the power supply cable and open the device cover (see [paragraph 5.1](#))

2

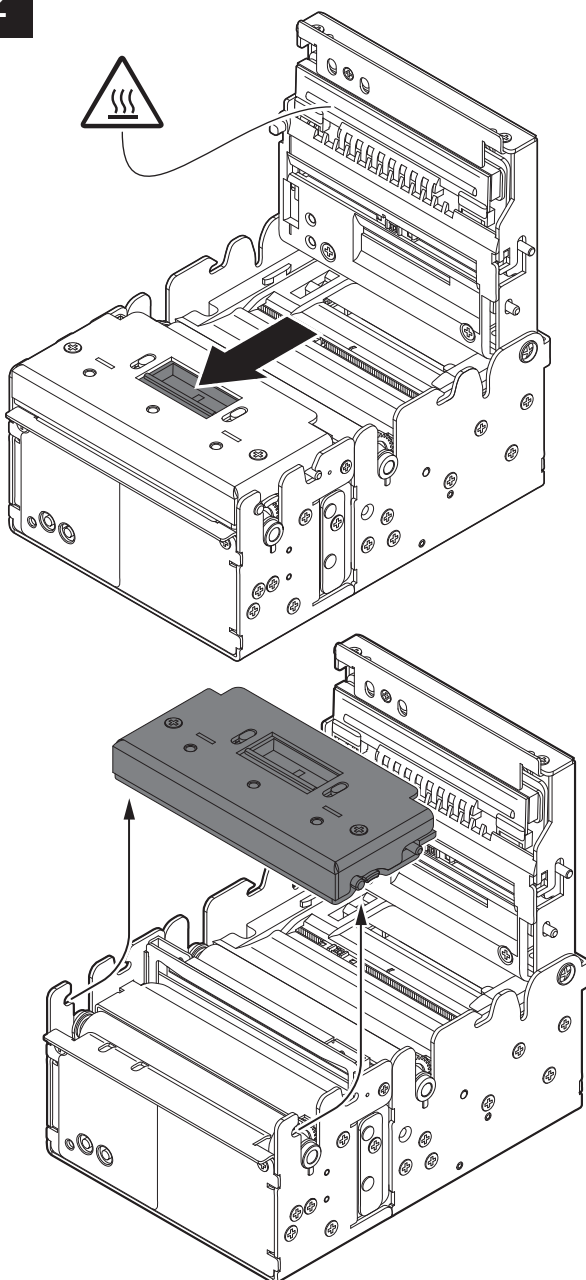

Push the release lever then lift and remove the presenter cover.

3

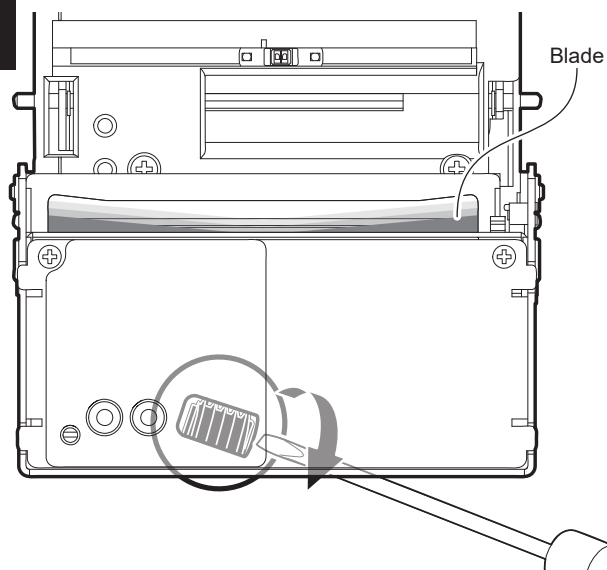

Insert a screwdriver in the inspector window and turn the worm screw to expose the autocutter blade.

4

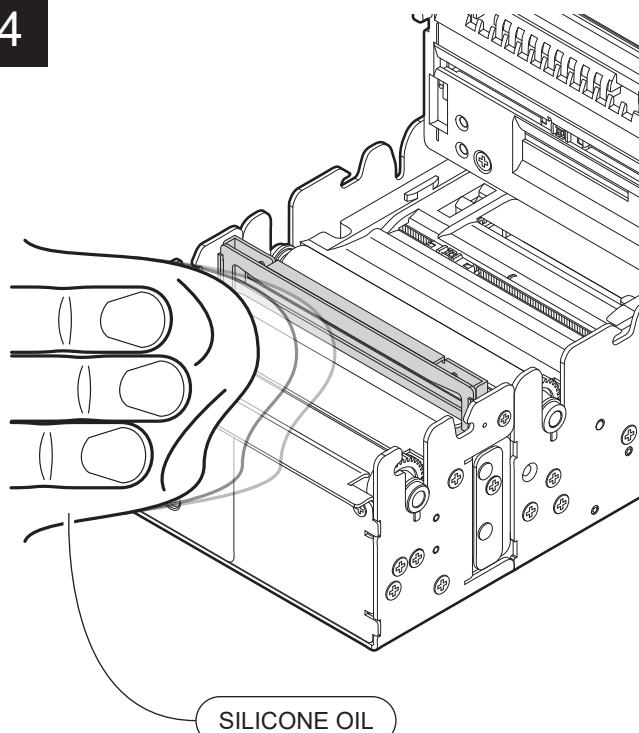

### ATTENTION:

Do not use alcohol, solvents, or hard brushes.  
Do not let water or other liquids get inside the device.



Clean the autocutter by using a non-abrasive cloth moistened with silicone oil.

## 8.5 Upgrade firmware

Firmware upgrade can be performed by using the “PrinterSet” software tool available on [www.custom4u.it](http://www.custom4u.it). To upgrade firmware, proceed as follows.

1



Login to the website [www.custom4u.it](http://www.custom4u.it), type in the product code of the device and download the latest firmware release available.

2

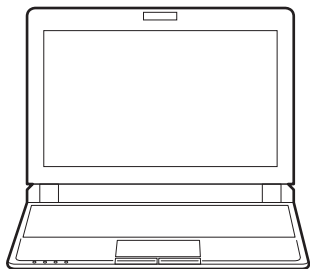

Connect the device to a PC directly (see [paragraph 4.3](#)), without using HUB devices.

3

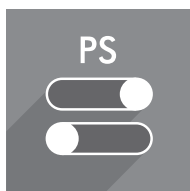

Start the “PrinterSet” software tool.

4

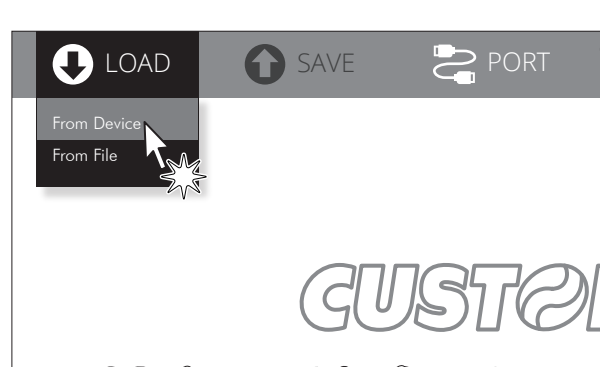

Click on LOAD > FROM DEVICE and select the device connected to the PC.

5

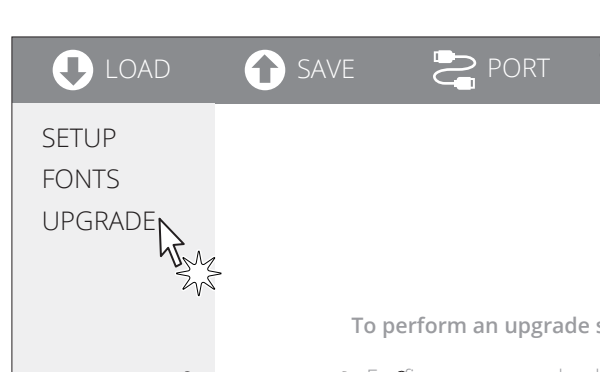

Click on UPGRADE and follow the instructions shown on the screen.

**ATTENTION:** During upgrade, it is strongly advised against disconnecting the communication cable or to remove the power supply of PC or device.



# 9 SPECIFICATION

## 9.1 Hardware specifications

GENERAL	
Sensors	Head temperature, paper presence, cover open, external low paper, mobile detectors of black mark or translucent gap/hole,
Display	
TK180 MET 1 TK180 MET 2 TK180 MET 3 TK180 CUT 1 TK180 CUT 2 TK180 CUT 3	Dot matrix 120x17 LCD module size 124.1 (W) x 26 (H) x 5.8 (T) mm
TK180 PLAS 1 TK180 PLAS 2 TK180 PLAS 3	Dot matrix 122x32 LCD module size 83.4 (W) x 28.2 (H) x 5.1 (T) mm
Emulations	CUSTOM/POS SVELTA
Printing driver	Windows XP VISTA (32/64 bit) Windows 7 (32/64 bit) Windows 8 (32/64 bit) Windows 8.1 (32/64 bit) Windows 10 (32/64 bit) Self-installing driver for Virtual COM (32/64 bit) OPOS Linux (32/64 bit) Android iOS
INTERFACES	
USB port	12 Mbit/s (USB 2.0 full speed)
RS232 serial port	from 1200 bps to 115200 bps
Ethernet port	10 Mbit/s, 100 Mbit/s
MEMORIES	
Receive buffer	16 kB
Flash memory	1 MB internal + 8 MB external (of which 4 MB available for user)



---

RAM memory 128 kB internal + 8 MB external

---

**PRINTER**

---

Resolution 203 dpi (8 dot/mm)

---

Printing method Thermal, fixed head

---

Head life <sup>(1)</sup>

---

Abrasion resistance <sup>(2)</sup> 100 km (with recommended paper, 12.5% duty cycle)

---

Pulse durability 100 M (referred to each dot)

---

Printing width 80 mm

---

Printing mode Normal, 90°, 180°, 270°

---

Printing format Height/Width from 1 to 8, bold, reverse, underlined, italic

---

Character fonts

---

CUSTOM/POS emulation 54 character code tables (see [paragraph 9.11](#))  
2 TrueType font <sup>(3)</sup>,  
extended chinese GB18030-2000

---

SVELTA emulation 20 embedded fonts,  
2 TrueType font <sup>(3)</sup>

---

Printable barcode UPCA, UPCE, EAN13, EAN8, CODE39, ITF,  
CODABAR, CODE93, CODE128, CODE32,  
PDF417, DATAMATRIX, AZTEC, QRCODE

---

Printing speed <sup>(1)(4)</sup> High Speed = 200 mm/s  
Normal = 150 mm/s  
High Quality = 100 mm/s

---

**PAPER**

---

Type of paper Thermal rolls, heat-sensitive side on outside of roll  
Thermal rolls, heat-sensitive side on inside of roll  
Thermal Fan-fold module with alignment black mark

---



---

Paper width

---

KPM180H 1  
KPM180H 2  
KPM180H 3  
KPM180H 4  
KPM180H 5  
TK180 MET 1  
TK180 MET 2  
TK180 CUT 1  
TK180 CUT 2  
TK180 PLAS 1  
TK180 PLAS 2

from 20 mm to 82.5 mm (2 mm step)

---

KPM180H 6  
TK180 MET 3  
TK180 CUT 3  
TK180 PLAS 3

54mm, 80mm, 82.5mm

---

Paper weight

from 70 g/m<sup>2</sup> to 255 g/m<sup>2</sup>

---

Paper thickness

max. 270 µm

---

Recommended paper

---

KPM180H 1  
KPM180H 2  
KPM180H 3  
TK180 MET 1  
TK180 MET 2  
TK180 CUT 1  
TK180 CUT 2  
TK180 PLAS 1  
TK180 PLAS 2

KANZAN KLS46 and KP460  
MITSUBISHI TF7067

---

Mandatory paper

---

KPM180H 4  
KPM180H 5  
KPM180H 6  
TK180 MET 3  
TK180 CUT 3  
TK180 PLAS 3

EEZEETAGS 2.0

---

External roll diameter <sup>(5)</sup>

max. 200 mm

---



External roll core diameter

KPM180H 1	
TK180 MET 1	
TK180 MET 2	
TK180 MET 3	25 mm (+ 1 mm)
TK180 PLAS 1	
TK180 PLAS 2	
TK180 PLAS 3	

KPM180H 2	
KPM180H 3	
KPM180H 4	
KPM180H 5	25 mm (+ 1 mm) with paper thermal side on outside
KPM180H 6	50 mm (+ 1 mm) with paper non-thermal side on outside
TK180 CUT 1	
TK180 CUT 2	
TK180 CUT 3	

Paper end Not attached to roll core

Core type Cardboard or plastic

**AUTOCUTTER**  
(KPM180H 2, KPM180H 3, KPM180H 4, KPM180H 5, KPM180H 6  
TK180 CUT 1, TK180 CUT 2, TK180 CUT 3)

Paper cut Total cut

Estimated life <sup>(1)</sup>

KPM180H 2	
KPM180H 3	
TK180 CUT 1	1000000 cuts (with paper thickness 200 µm, ambient temperature)
TK180 CUT 2	

KPM180H 4	
KPM180H 5	
KPM180H 6	500000 cuts (with paper thickness 100 µm, ambient temperature)
TK180 CUT 3	

**TRANSPONDER SPECIFICATIONS**  
(KPM180H 3, KPM180H 5, KPM180H 6  
TK180 CUT 2, TK180 CUT 3, TK180 MET 2, TK180 MET 3  
TK180 PLAS 2, TK180 PLAS 3)

Supported transponders  
(UHF Ultra High Frequency  
RFID 900 MHz)

UHF Gen 2



## DEVICE ELECTRICAL SPECIFICATIONS

Power supply 24 Vdc  $\pm$ 10% (optional external power supply)

Medium consumption <sup>(6)</sup> 1.6 A

Typical consumption <sup>(4)</sup> 1.5 A

Standby consumption

KPM180H 1  
TK180 MET 1  
TK180 MET 2  
TK180 MET 3  
TK180 PLAS 1  
TK180 PLAS 2  
TK180 PLAS 3 0.04 A

KPM180H 2  
KPM180H 3  
KPM180H 4  
KPM180H 5  
KPM180H 6  
TK180 CUT 1  
TK180 CUT 2  
TK180 CUT 3 0.07 A

ELECTRICAL SPECIFICATIONS POWER SUPPLY code 963GE020000071  
(optional for KPM180H 1, KPM180H 2, KPM180H 3, KPM180H 4, KPM180H 5, KPM180H 6  
included with TK180 MET 1, TK180 CUT 1, TK180 CUT 2, TK180 CUT 3, TK180 MET 2, TK180 MET 3  
TK180 PLAS 1, TK180 PLAS 2, TK180 PLAS 3)

Power supply voltage from 100 Vac to 240 Vac

Frequency from 50 Hz to 60 Hz

Output 24 V, 2.5 A

Power 60 W



## ENVIRONMENTAL CONDITIONS

### Operating temperature

KPM180H 1	
KPM180H 2	
KPM180H 3	
KPM180H 4	from -10°C to +60°C <sup>(7)</sup>
KPM180H 5	
KPM180H 6	

TK180 MET 1	
TK180 MET 2	
TK180 MET 3	
TK180 CUT 1	
TK180 CUT 2	from 0°C to +40°C
TK180 CUT 3	
TK180 PLAS 1	
TK180 PLAS 2	
TK180 PLAS 3	

Relative humidity (RH)	from 10% to 85% (w/o condensation)
------------------------	------------------------------------

Storage temperature	from -20 °C to +70 °C
---------------------	-----------------------

Storage relative humidity (RH)	from 10% to 90% (w/o condensation)
--------------------------------	------------------------------------

#### NOTES:

- (1) : Respecting the regular schedule of cleaning for the device components.
- (2) : Damages caused by scratches, ESD and electromigration are excluded.
- (3) : "Veramono.ttf" and "Vera.ttf" are installed on the device. It is possible to install additional TrueType fonts by using the "PrinterSet" software tool available on [www.custom4u.it](http://www.custom4u.it).
- (4) : Referred to a standard CUSTOM receipt (L=10 cm, Density = 12.5% dots on).
- (5) : For external rolls diameter larger than Ø100mm it's recommended to use a paper pretensioning device.
- (6) : Referred to the UL measurements (Speed/Quality = High Speed, Print density = +50%, Ticket = 12.5% dots on, 1 ticket every 30 s).
- (7) : If you use the device with the power supply code 963GE020000071, supplied as an accessory, the operating temperature range is from 0 °C to +40 °C.





## 9.2 Character specifications

Character set		3	
Character density	11 cpi	15 cpi	20 cpi
Number of columns	35	45	64
Chars / s	2370	3047	4266
Lines / s	66	66	66
Characters (L x H mm)-Normal	2.25 x 3	1.75 x 3	1.25 x 3

NOTE: Theoretical values.



## 9.3 Device dimensions

All the dimensions shown in following figures are in millimetres and referred to devices with closed covers.

### KPM180H 1

Length	97.5 mm
Height	67 mm (with cover closed) 142 mm (with cover open)
Width	108 mm
Weight	800 g

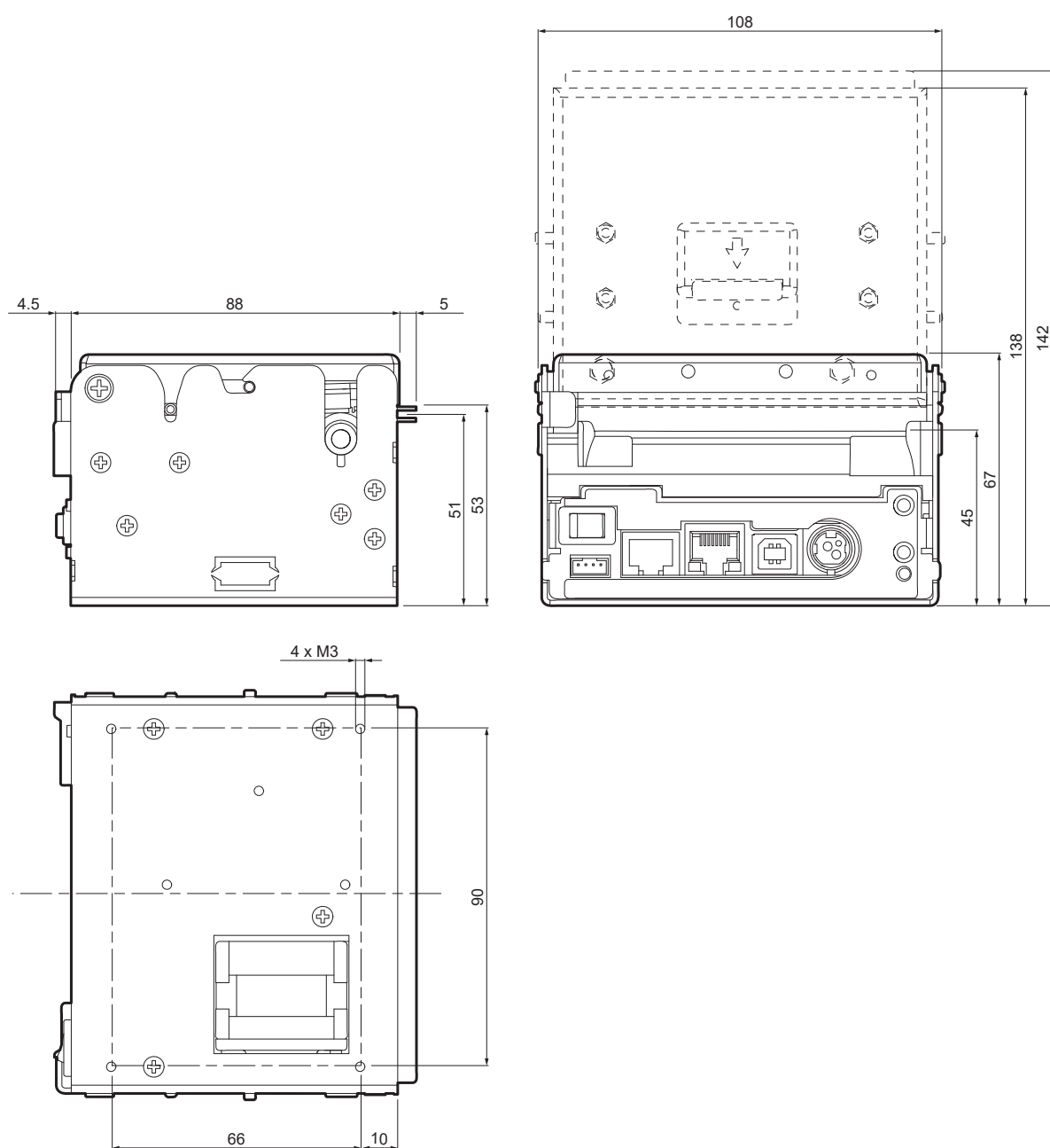



**KPM180H 2, KPM180H 4, KPM180H 6**

Length	149.5 mm
Height	67.5 mm (with cover closed) 140 mm (with cover open)
Width	108 mm
Weight	1500 g

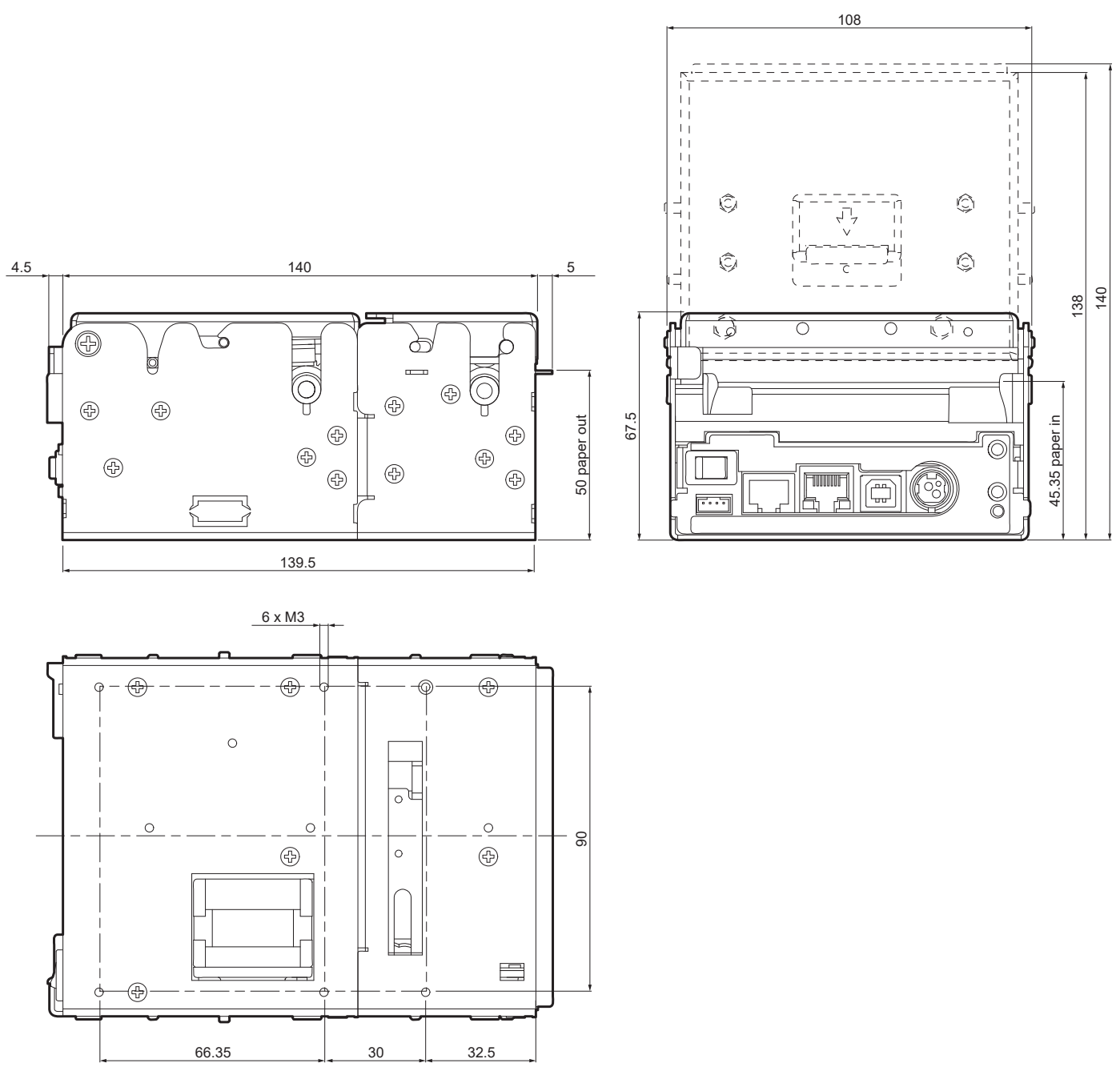



**KPM180H 2 with optional RFID module, KPM180H 3**  
**KPM180H 4 with optional RFID module, KPM180H 5**

Length	234.7 mm
Height	67.5 mm (with cover closed) 140 mm (with cover open) 91 mm (with RFID reader open)
Width	114 mm
Weight	1780 g

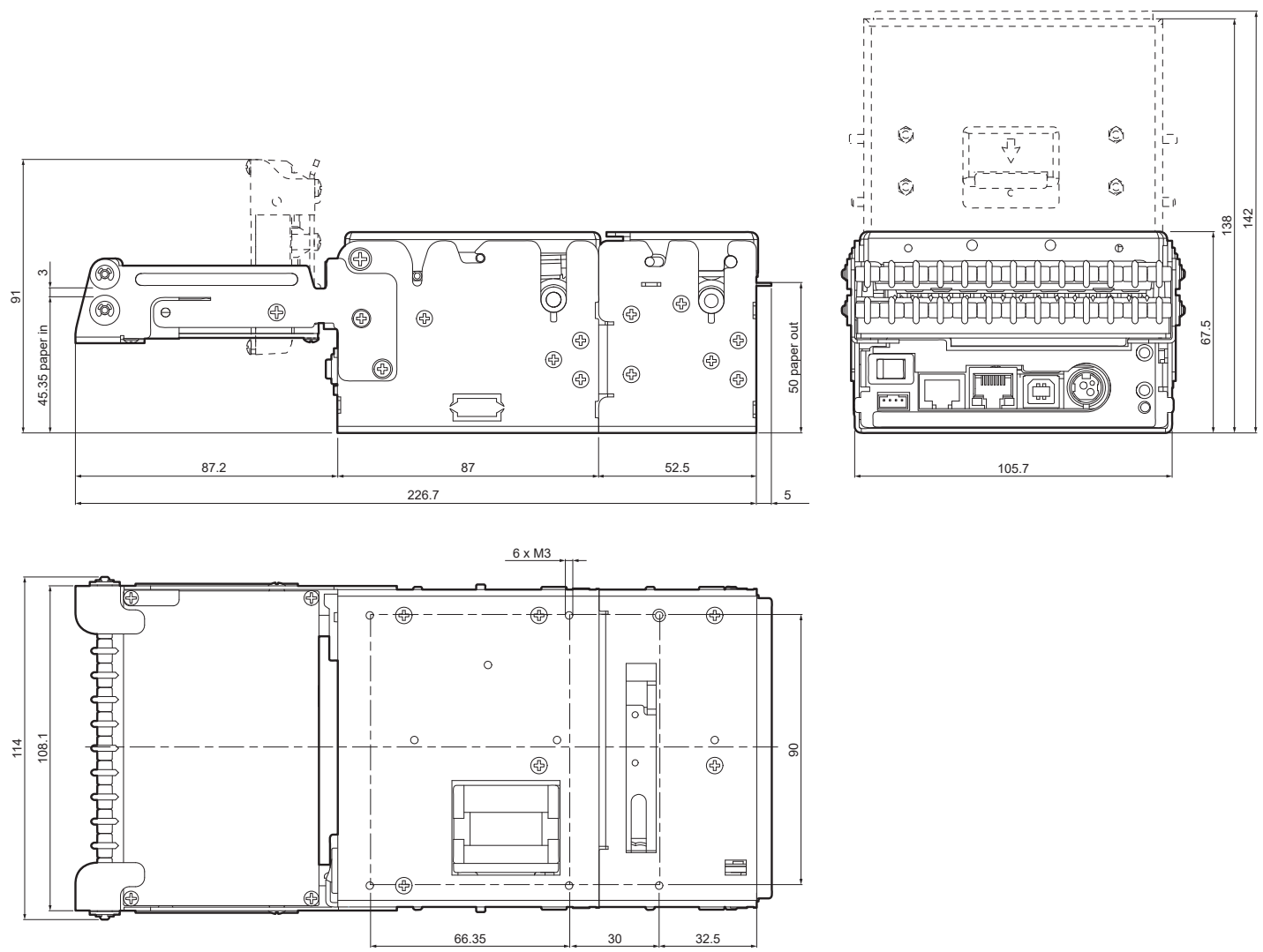



**TK180 MET 1, TK180 MET 3**

Length	119 mm
Height	85.2 mm
Width	145.7 mm
Weight	2240 g

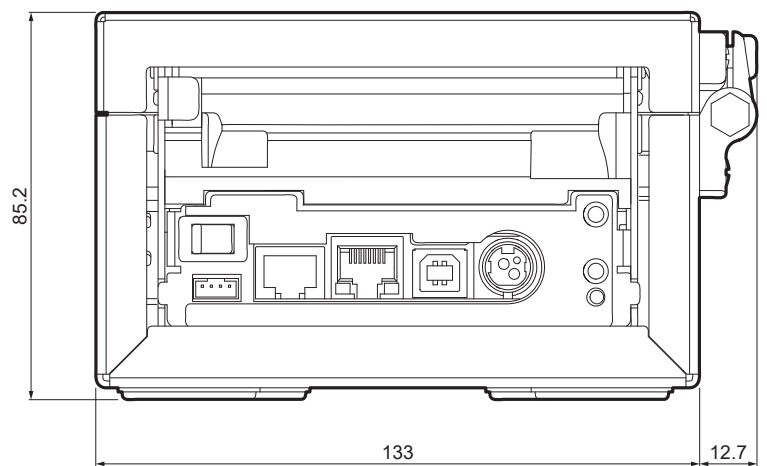
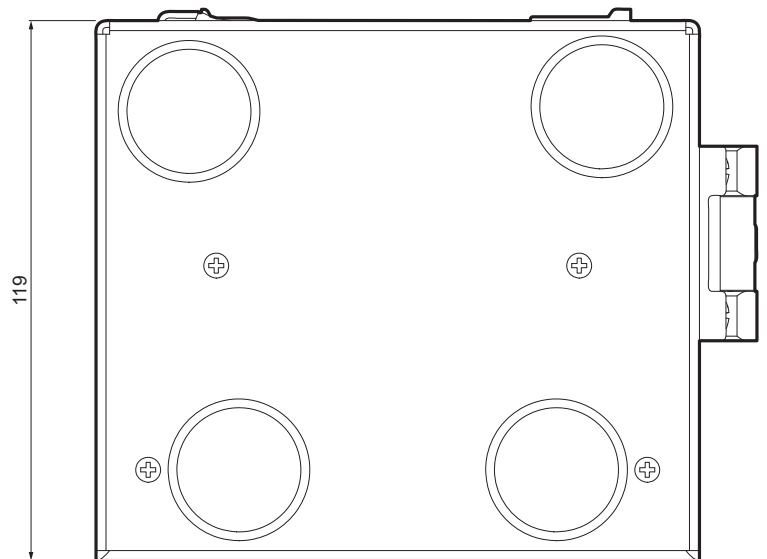
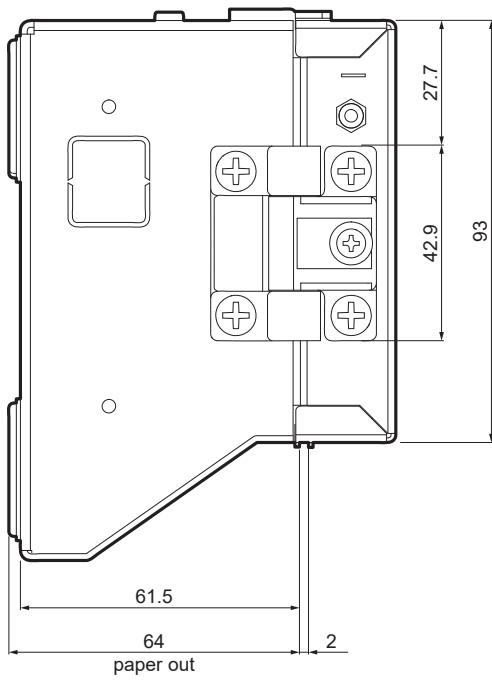



**TK180 CUT 1, TK180 CUT 3**

Length	171.5 mm
Height	85.2 mm
Width	145.7 mm
Weight	3000 g

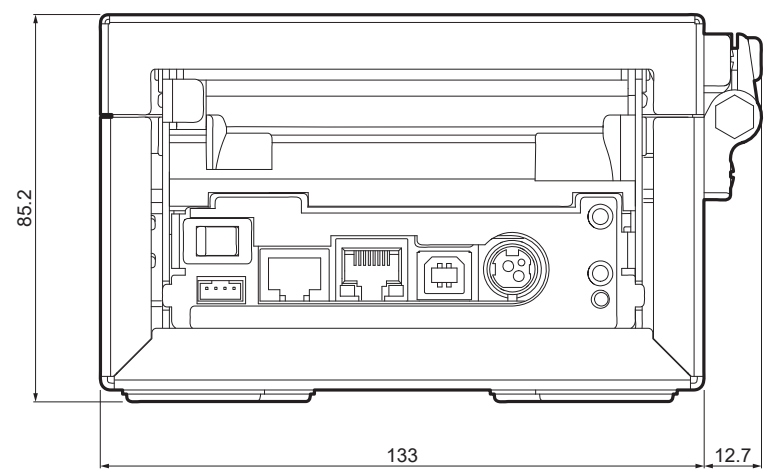
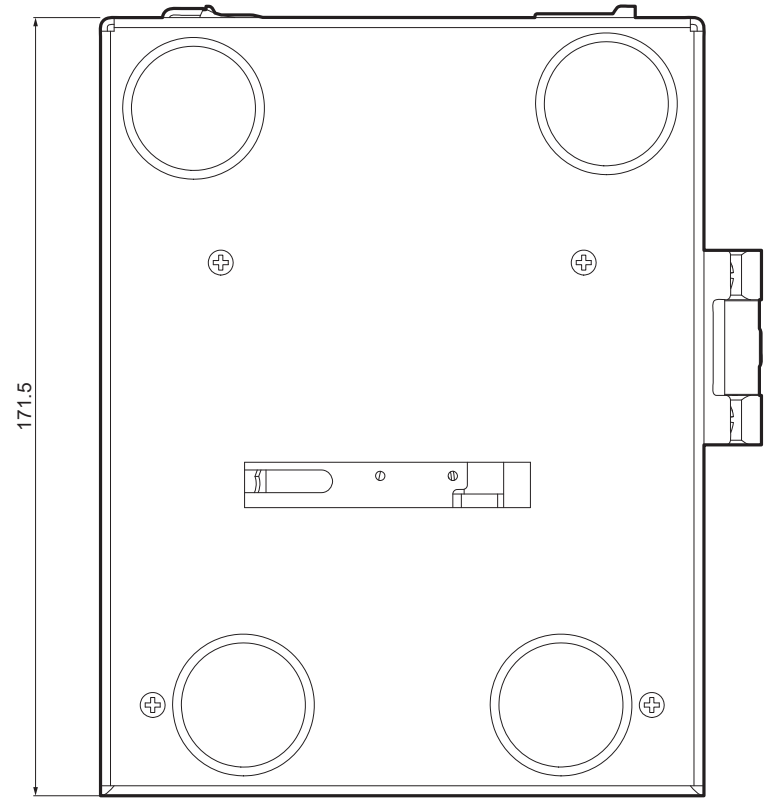
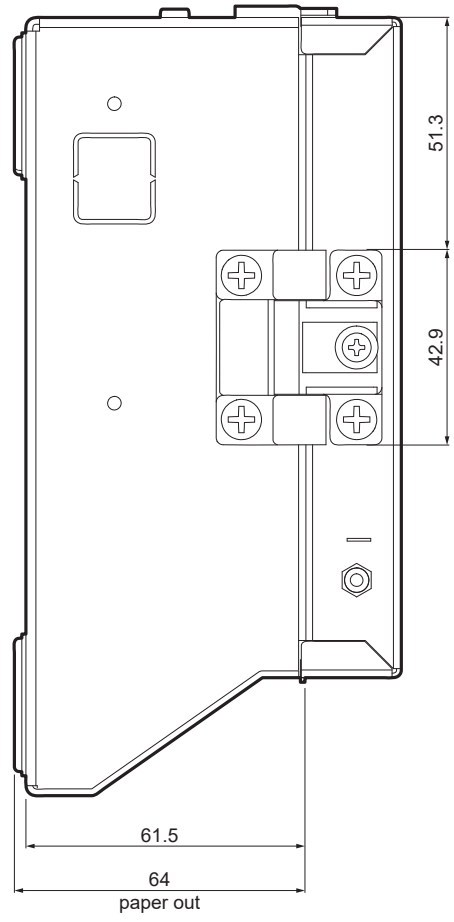



## **TK180 MET 1 with optional RFID module, TK180 MET 2**

Length	204.2 mm
Height	85.2 mm
Width	145.7 mm
Weight	2520 g

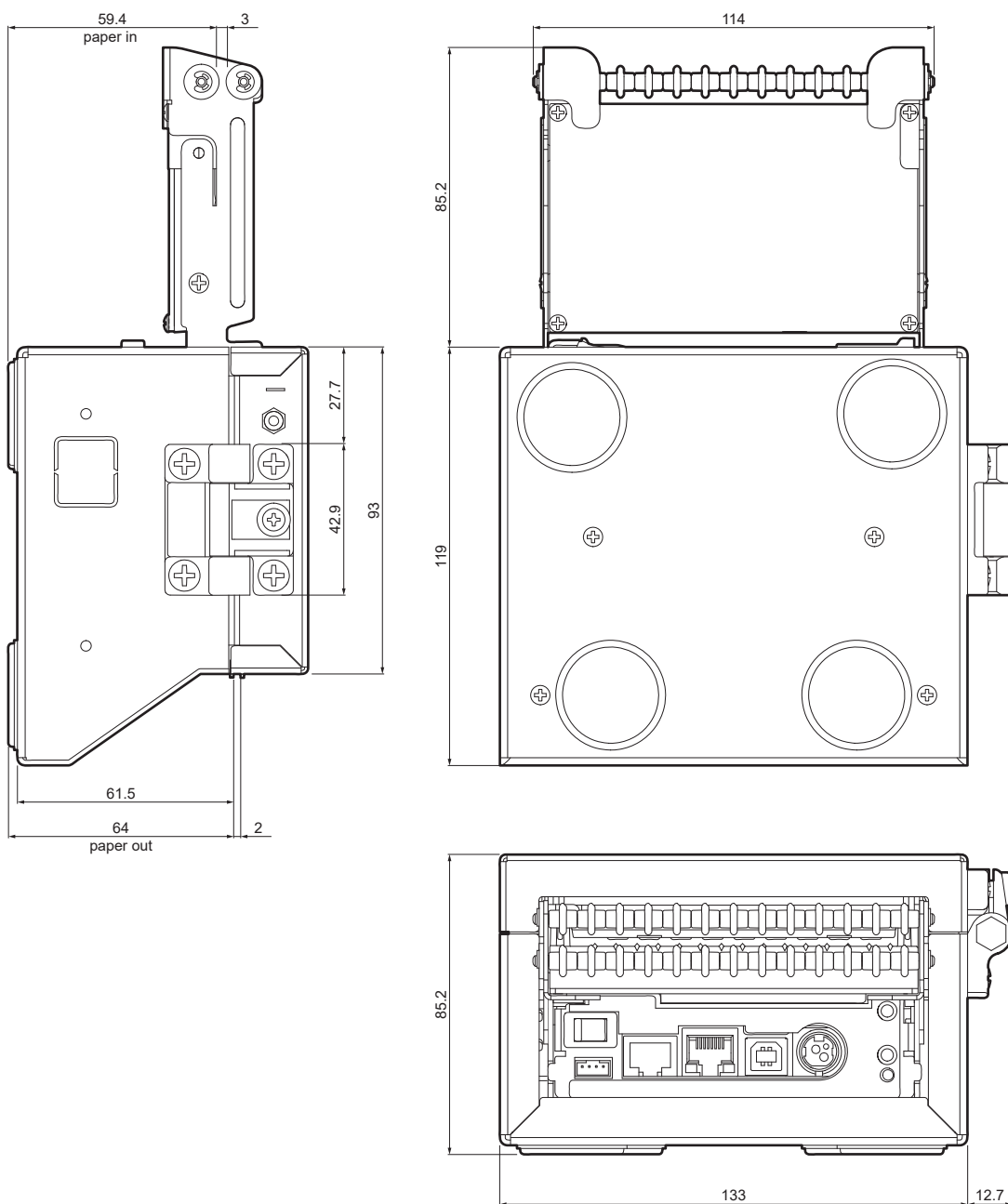



**TK180 CUT 1 with optional RFID module, TK180 CUT 2**

Length	256.7 mm
Height	85.2 mm
Width	145.7 mm
Weight	3280 g

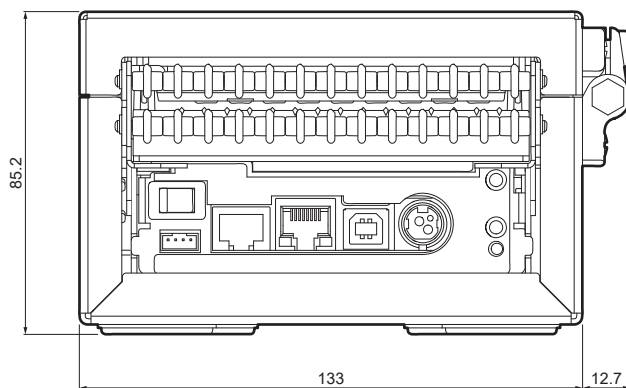
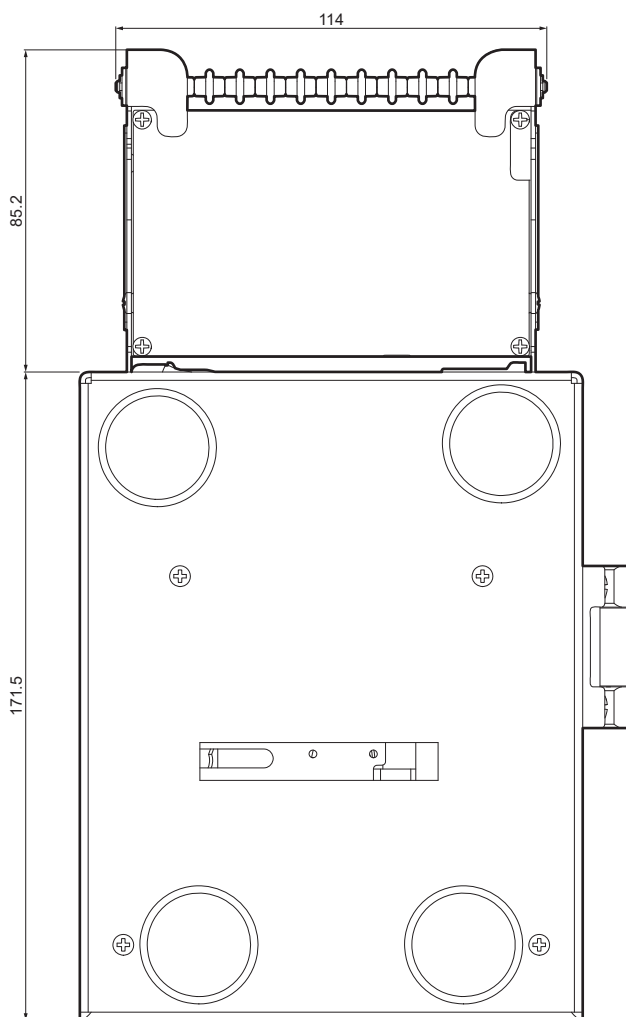
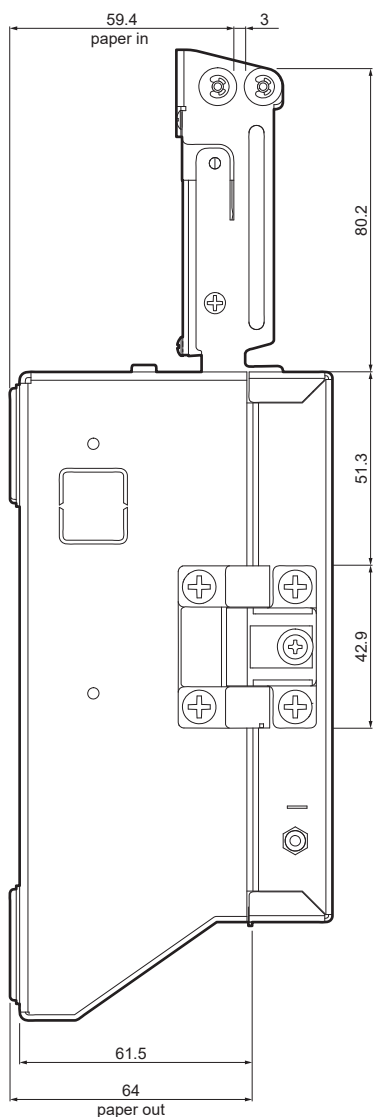





**TK180 PLAS 1, TK180 PLAS 3**

Length	185.9 mm
Height	118.9 mm
Width	130 mm
Weight	1940 g

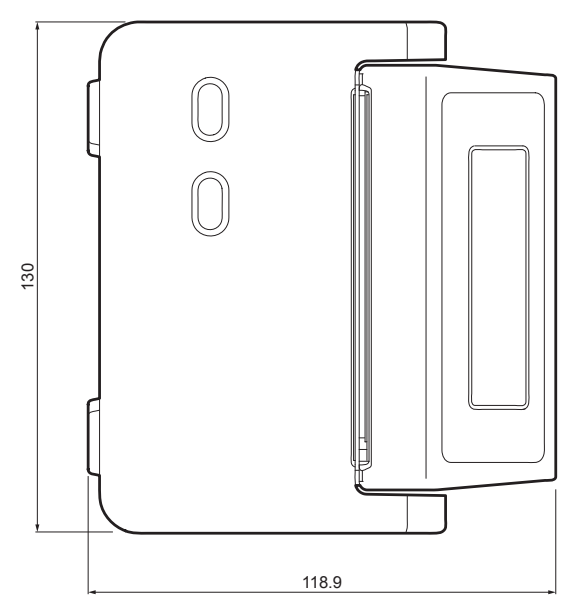
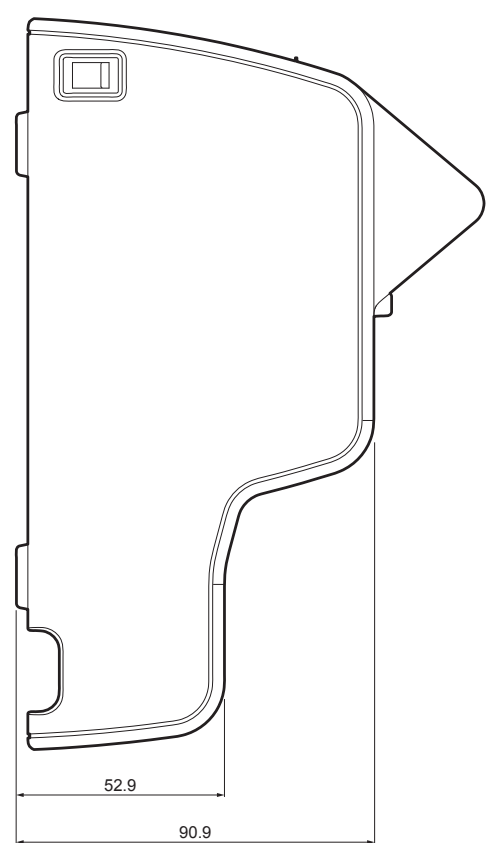
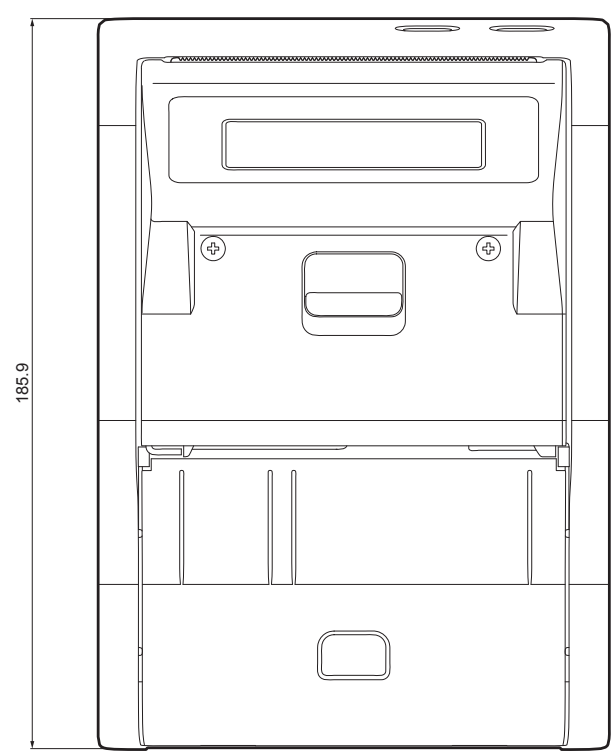



**TK180 PLAS 1 with optional RFID module. TK180 PLAS 2**

Length	194.1 mm
Height	118.9 mm
Width	130 mm
Weight	2220 g

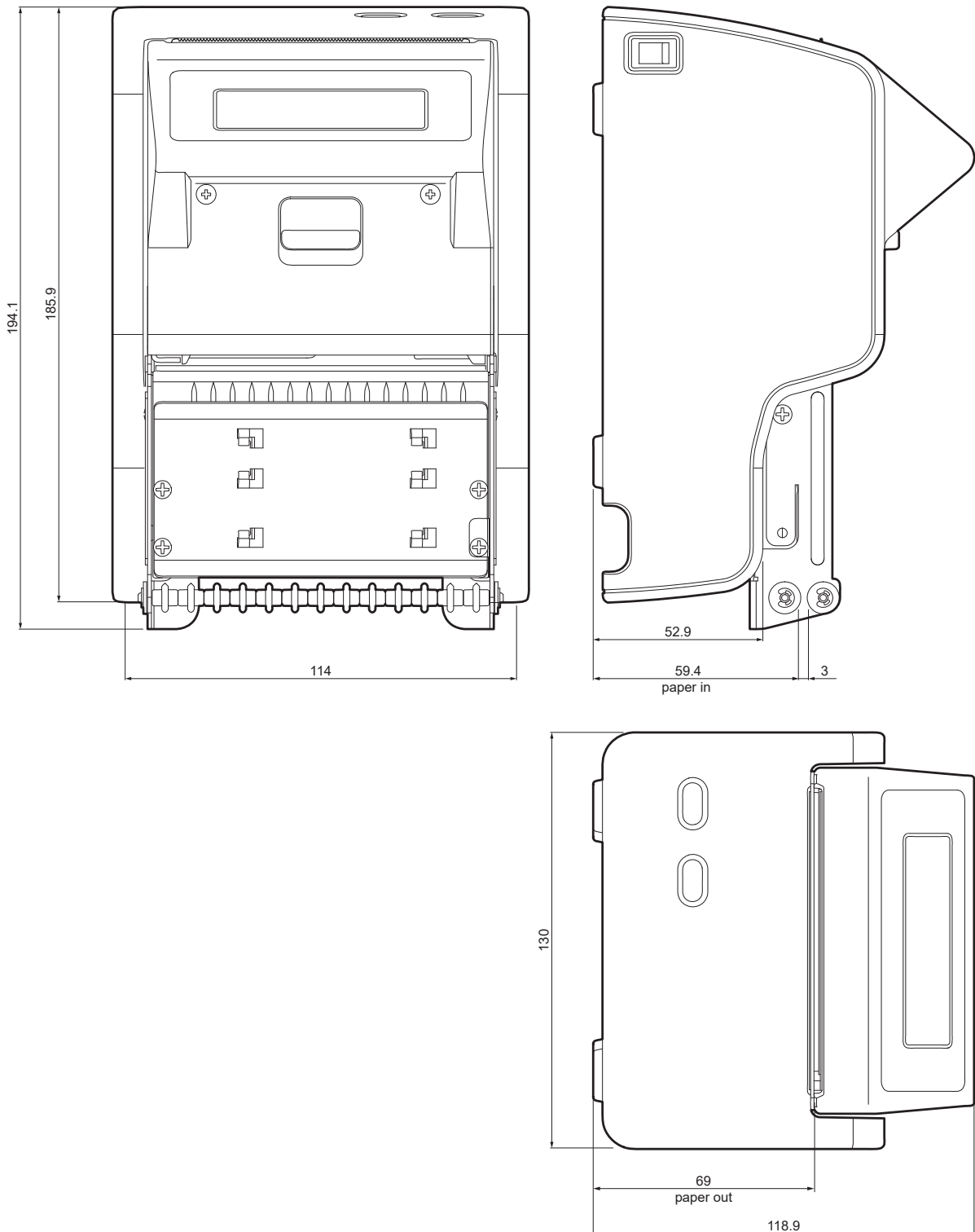



## 9.4 Device dimensions with pretensioner modules 976AH03000001 (optional)

All the dimensions shown in following figures are in millimetres and referred to devices with closed covers.

### KPM180H 1

Length	169.6 mm
Height	90 mm
Width	115 mm
Weight	1230 g

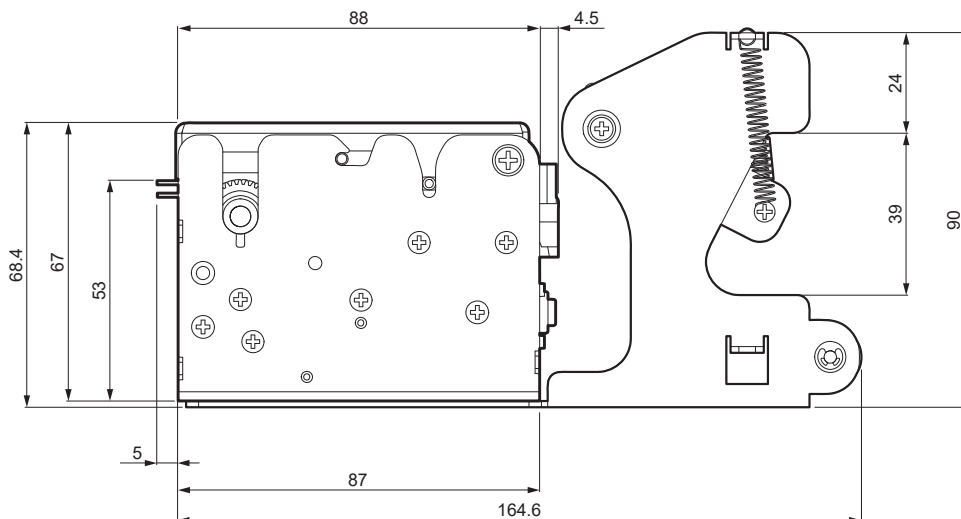
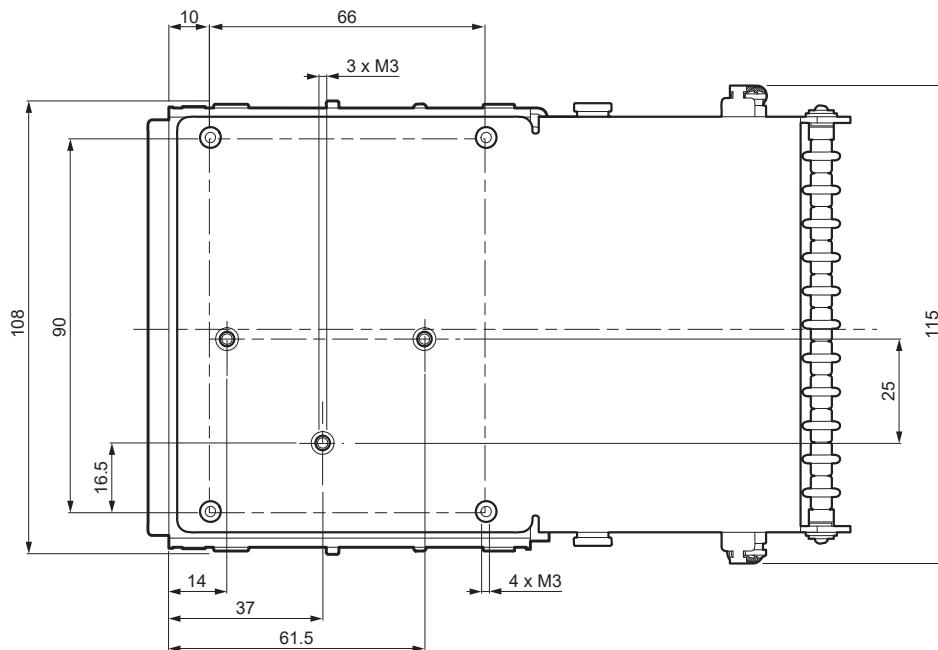



**KPM180H 2**

Length	222 mm
Height	90 mm
Width	115 mm
Weight	1930 g

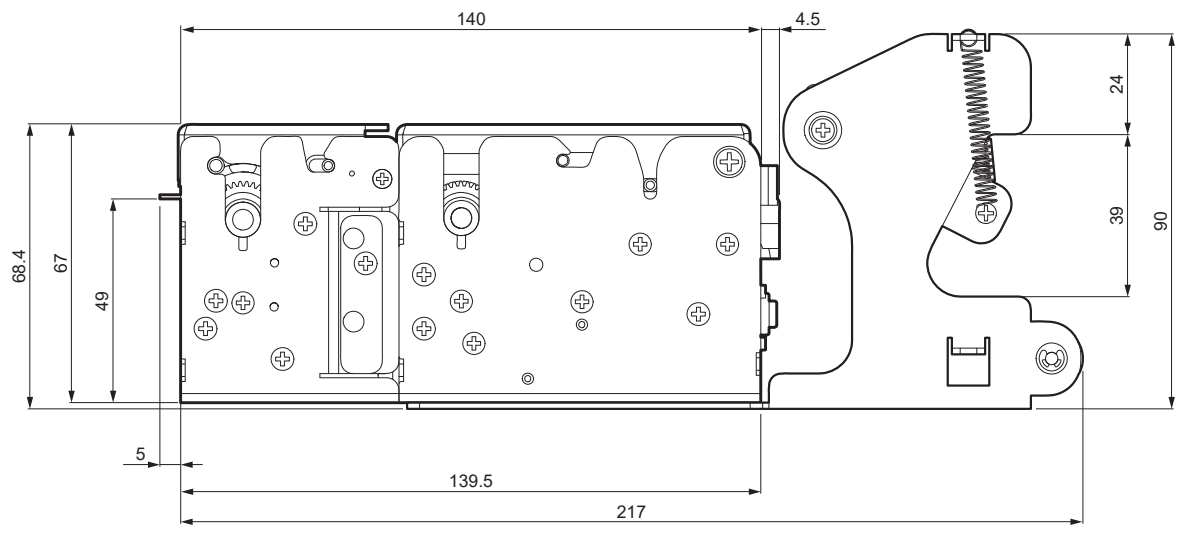
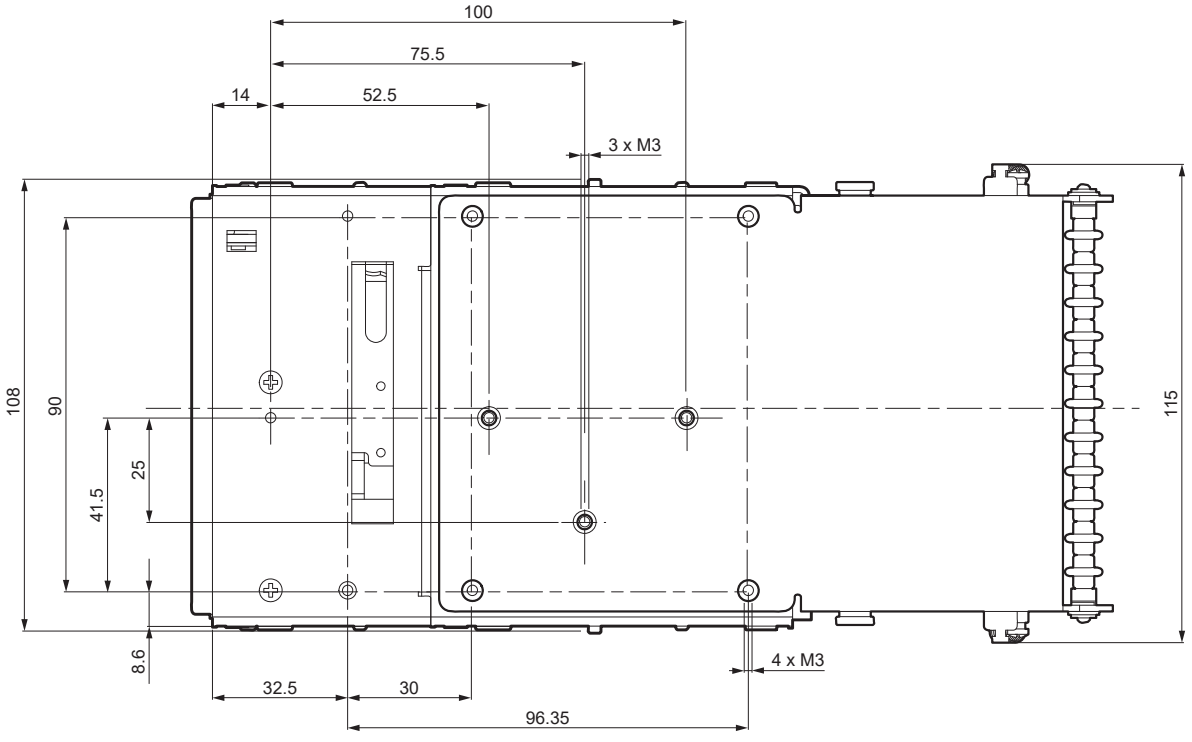



## 9.5 Device dimensions with paper roll holder code 974HL01000009 (optional)

All the dimensions shown in following figures are in millimetres and referred to devices with closed covers.

### TK180 MET 1, TK180 MET 3

Length	339 mm
Height	160 mm
Width	145.7 mm

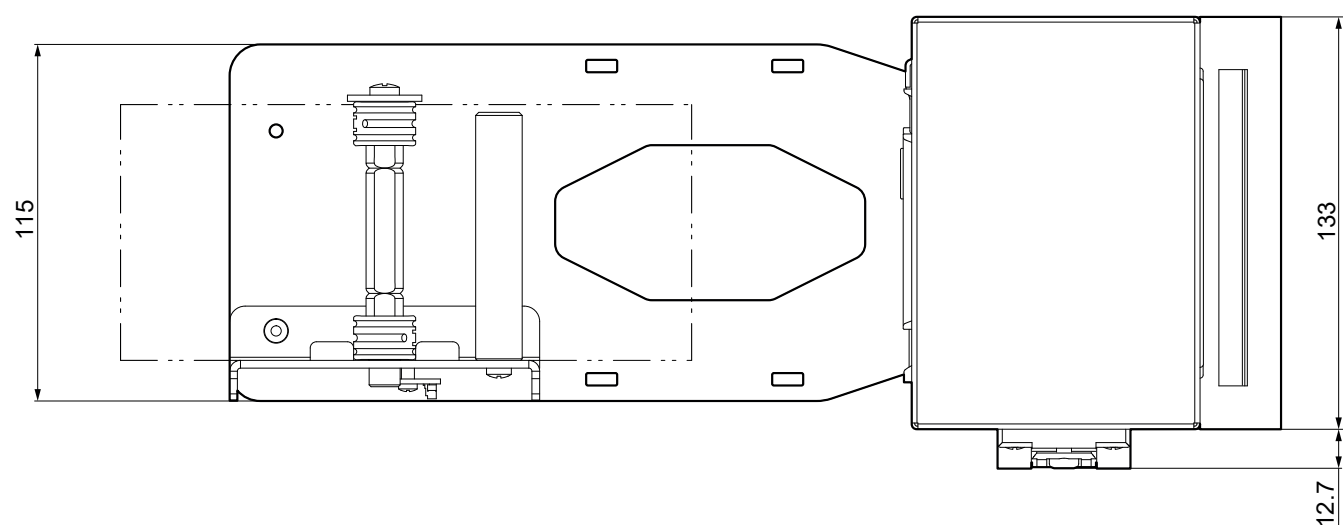
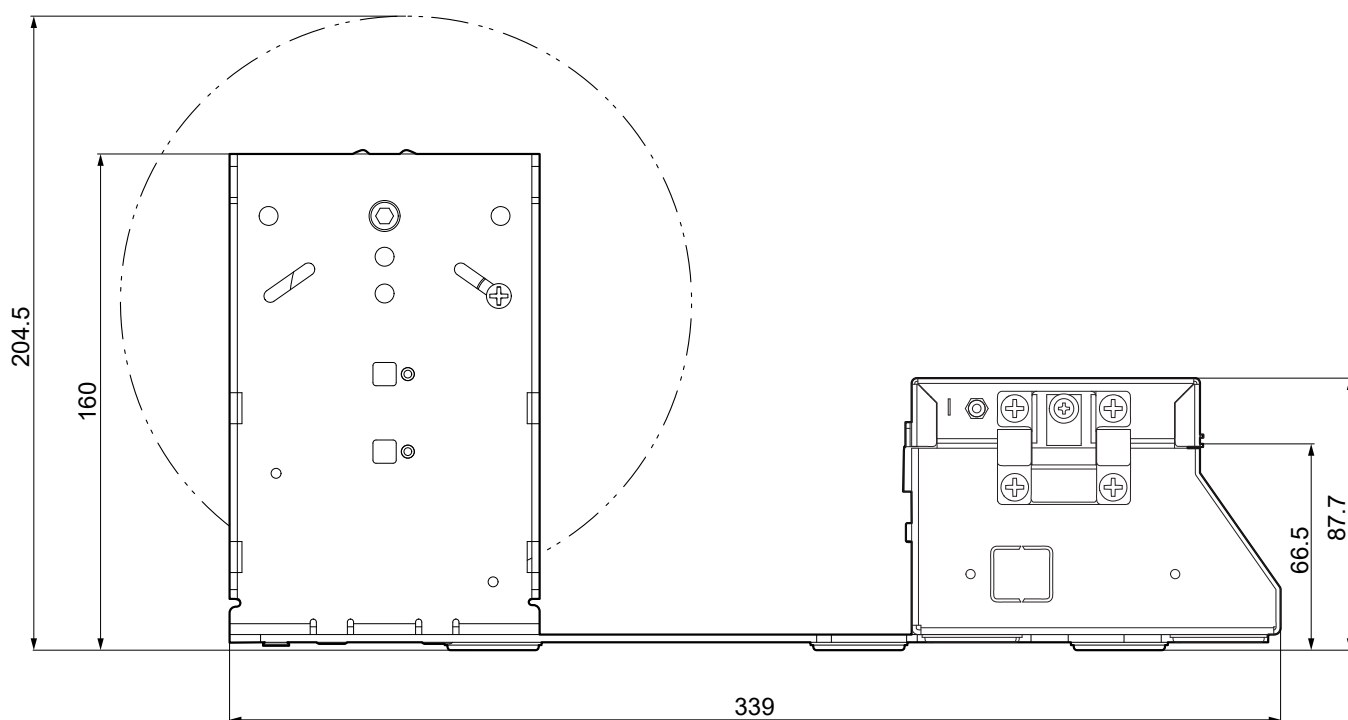



**TK180 CUT 1, TK180 CUT 3**

Length 391.5 mm

Height 160 mm

Width 145.7 mm

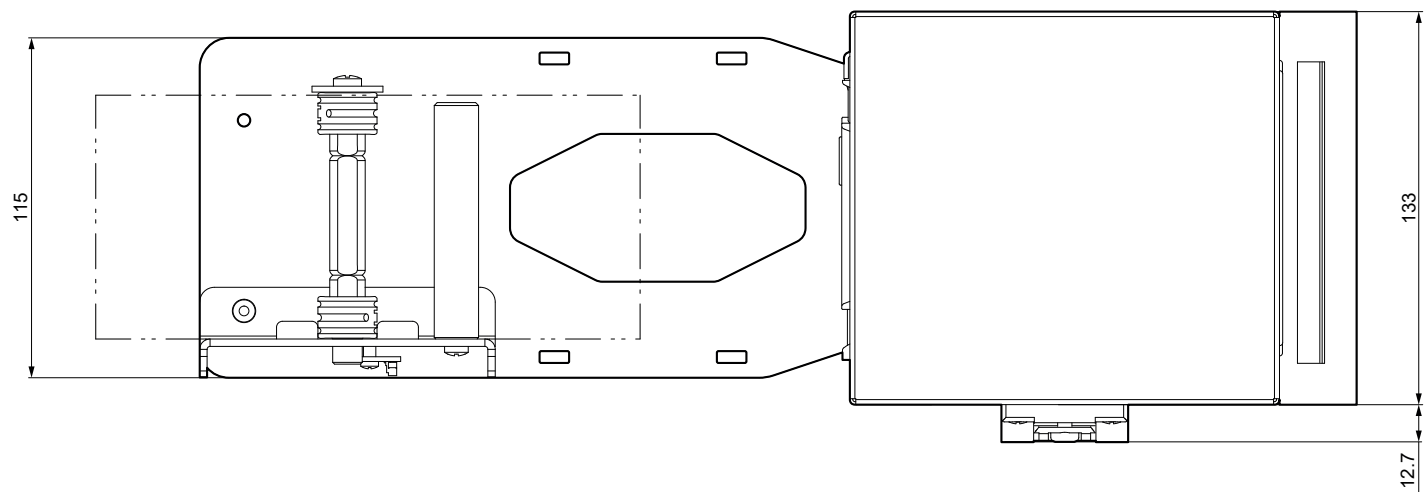
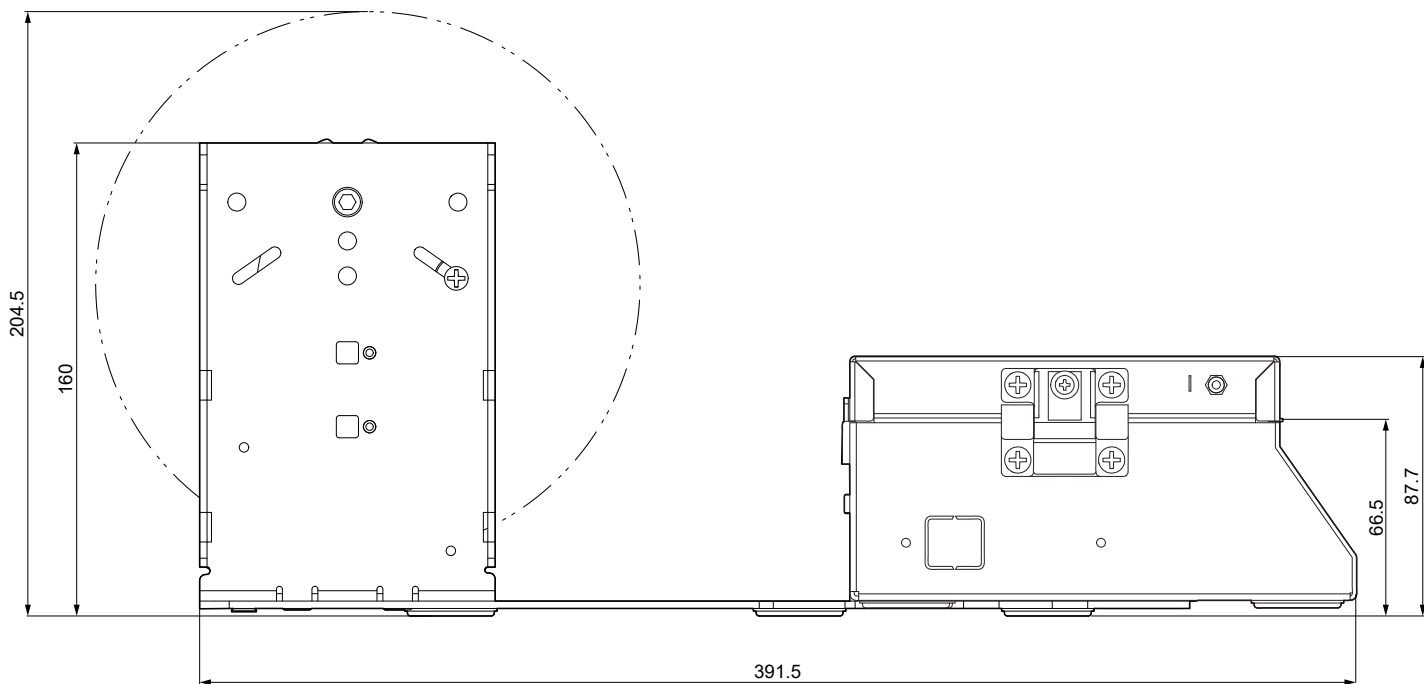



# TK180 MET 2

Length	339 mm
Height	160 mm
Width	145.7 mm

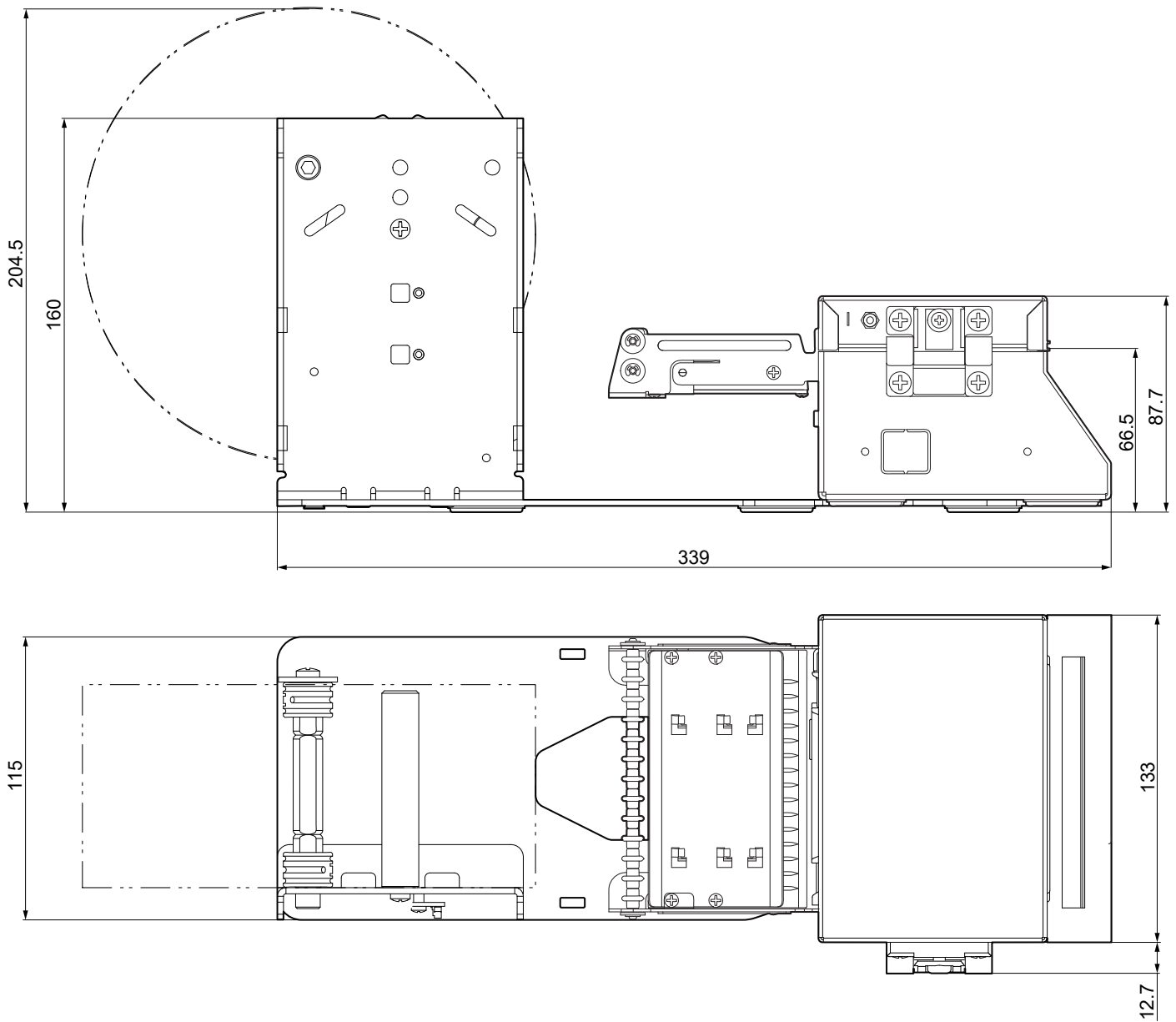



# TK180 CUT 2

Length 391.5 mm

Height 160 mm

Width 145.7 mm

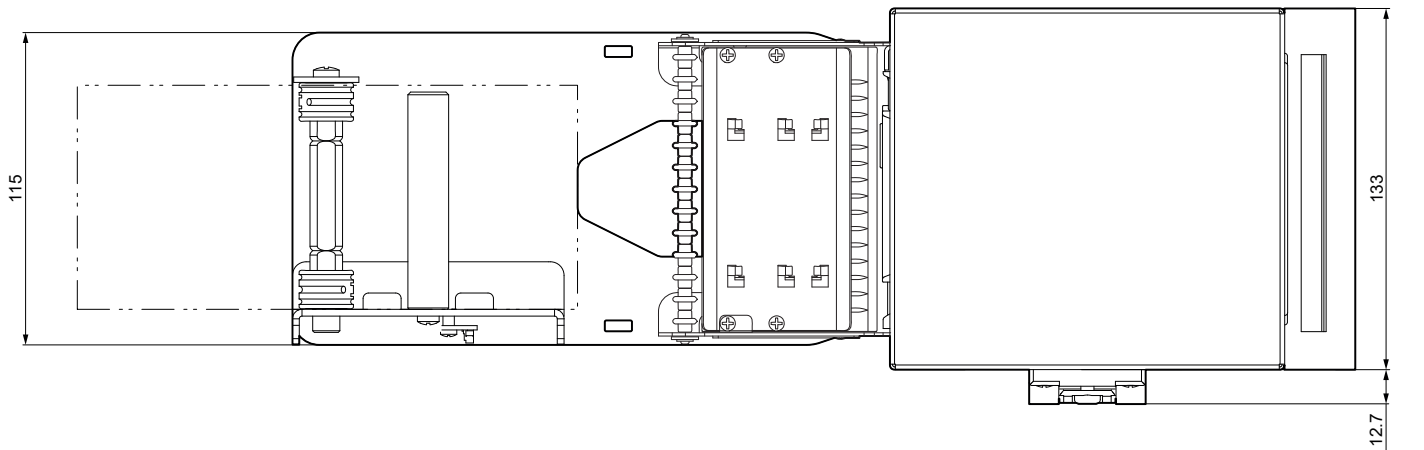
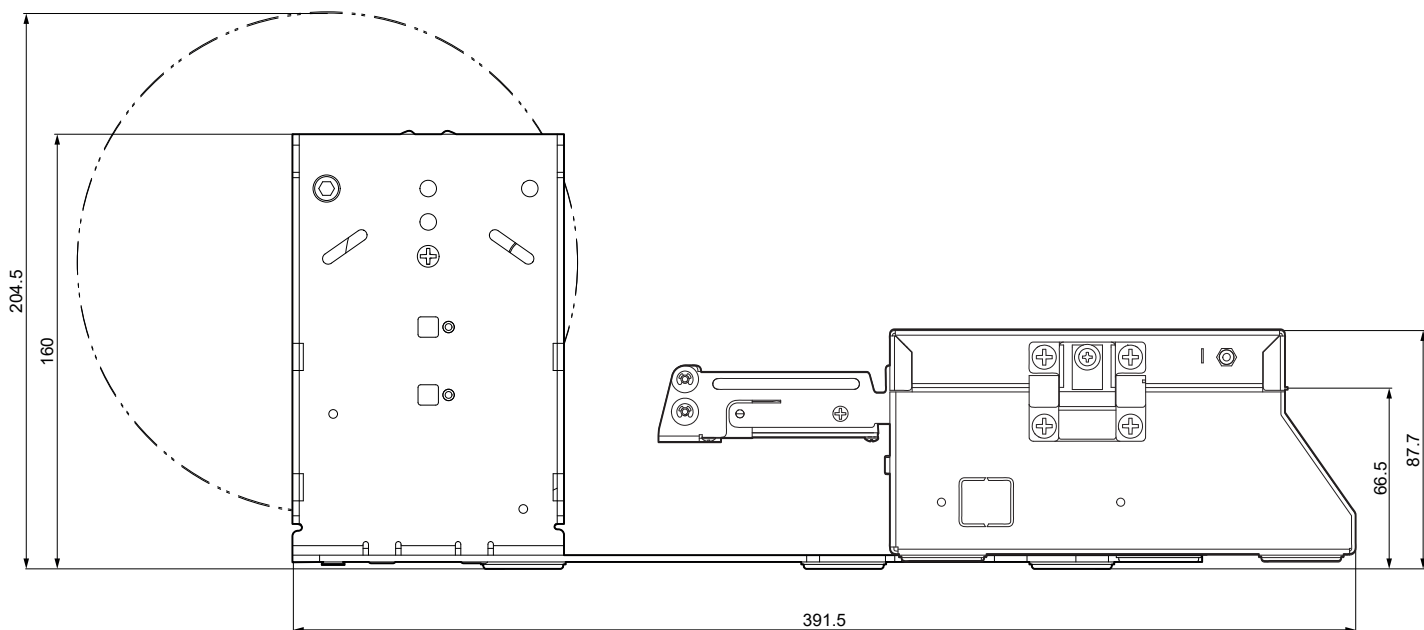





## 9.6 Device dimensions with paper roll holder code 974HL02000006 (optional)

All the dimensions shown in following figures are in millimetres and referred to devices with closed covers.

### TK180 PLAS 1, TK180 PLAS 3

Length	341.5 mm
Height	161 mm
Width	130 mm

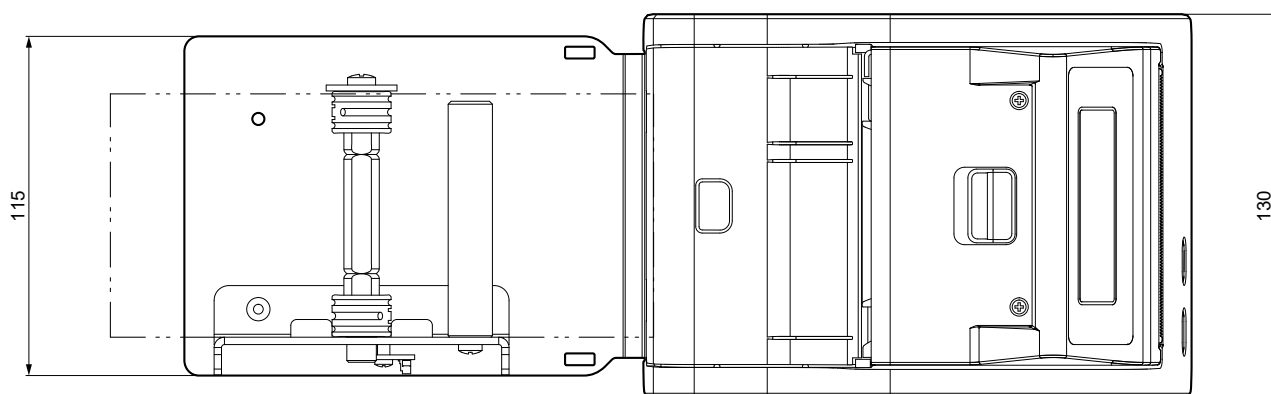
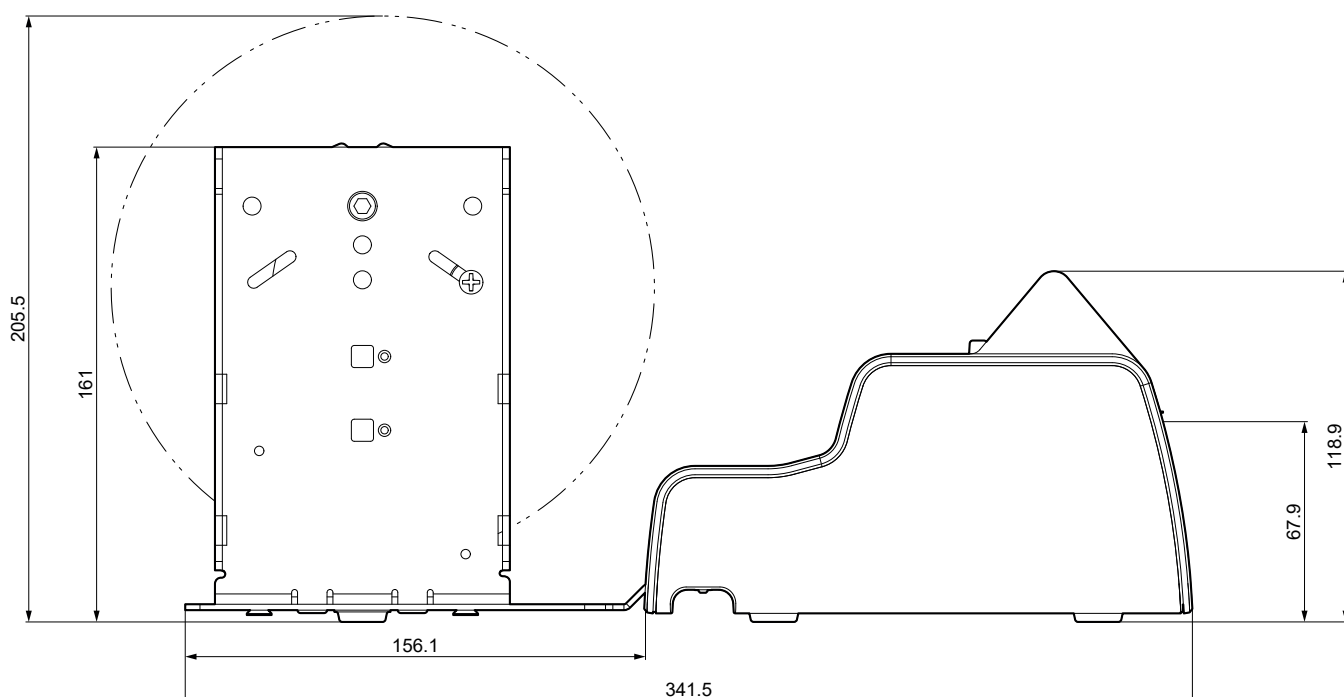



## TK180 PLAS 2

Length 341.5 mm

Height 161 mm

Width 130 mm

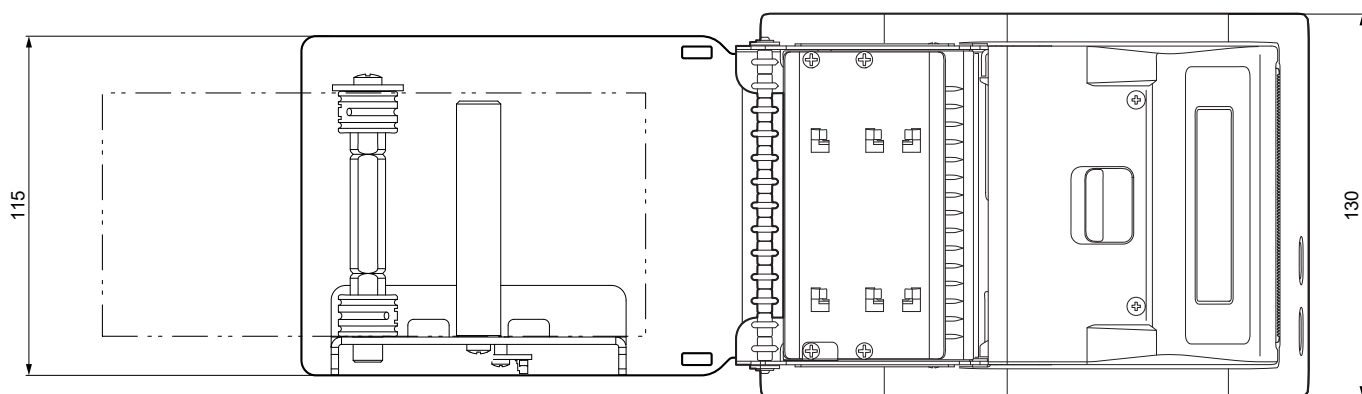
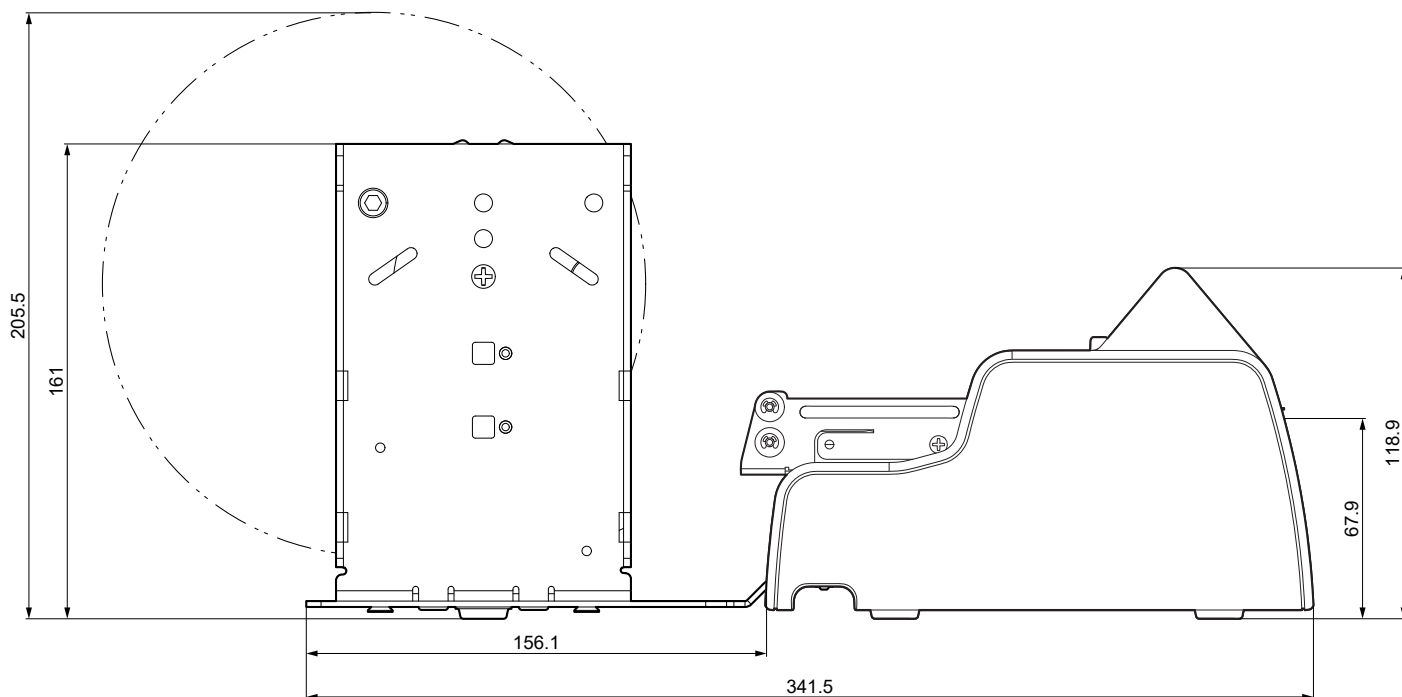



## 9.7 Device dimensions with ticket tray code 974HL010000010 (optional)

All the dimensions shown in following figures are in millimetres and referred to devices with closed covers.

### TK180 MET 1, TK180 MET 3

Length	419 mm
Height	115.8 mm
Width	145.6 mm

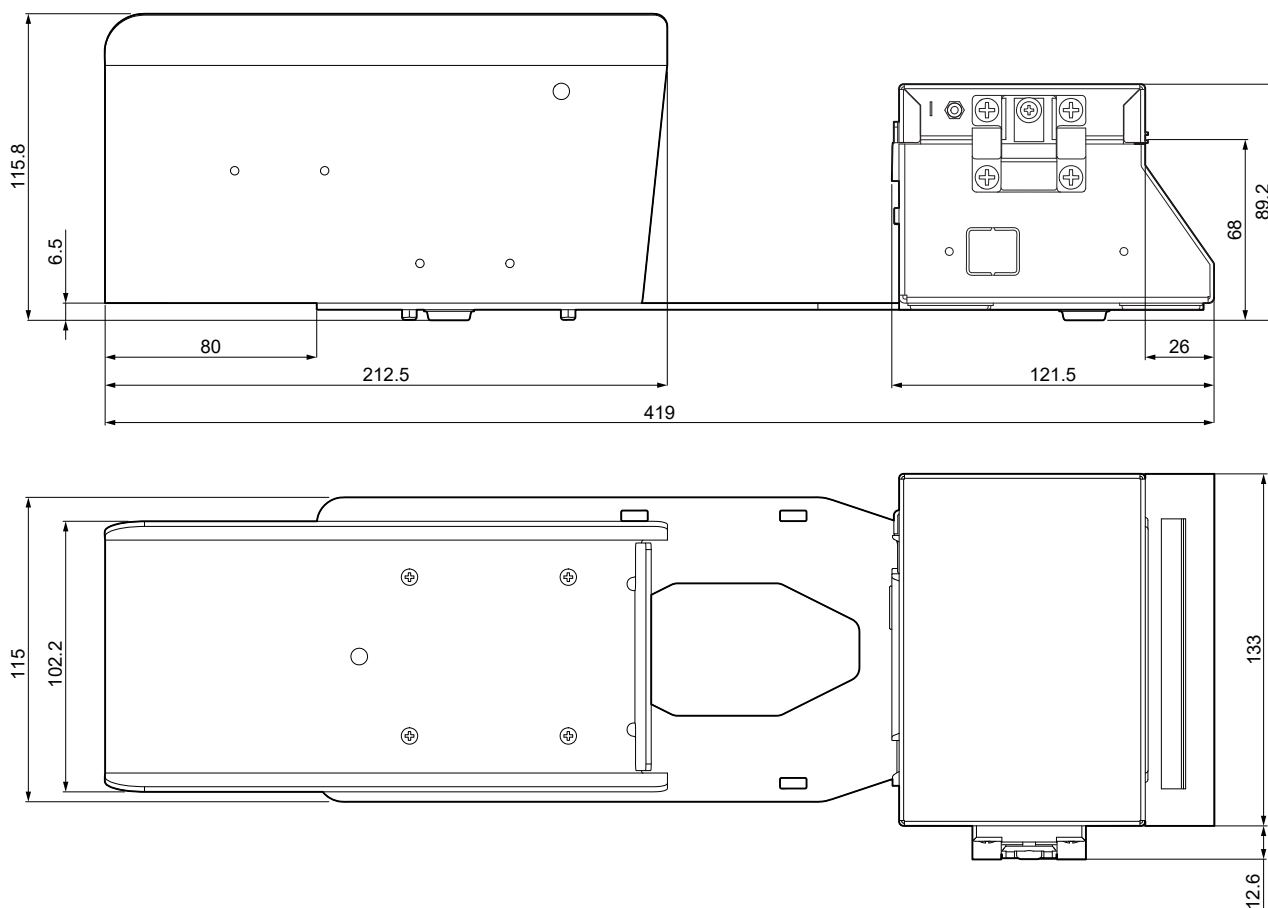



**TK180 CUT 1, TK180 CUT 3**

Length	471.5 mm
Height	115.8 mm
Width	145.6 mm

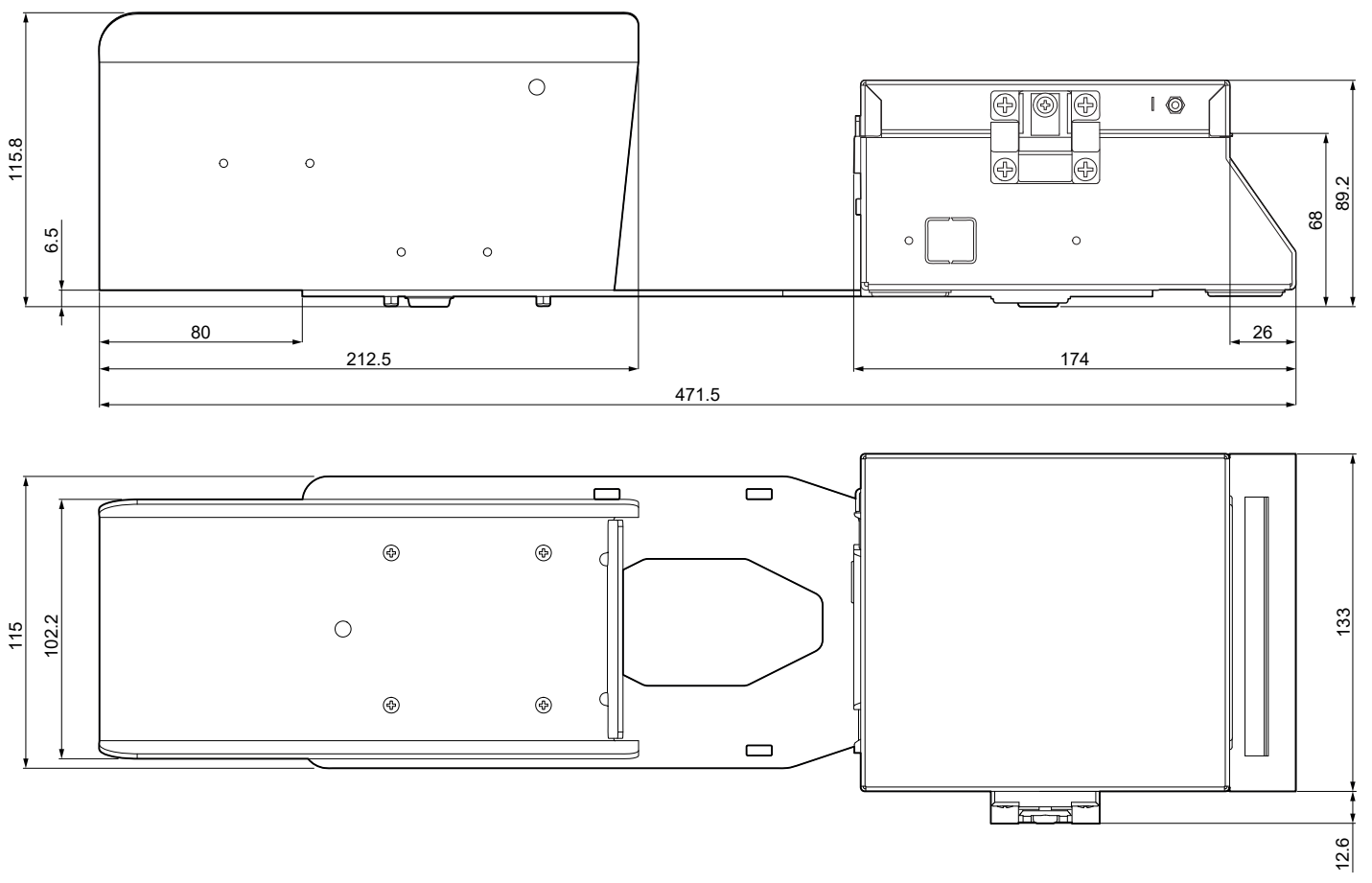



## 9.8 Device dimensions with ticket tray code 976HL01000007 (optional)

All the dimensions shown in following figures are in millimetres and referred to devices with closed covers.

### TK180 CUT 1, TK180 CUT 3

Length	377 mm
Height	197 mm
Width	148 mm

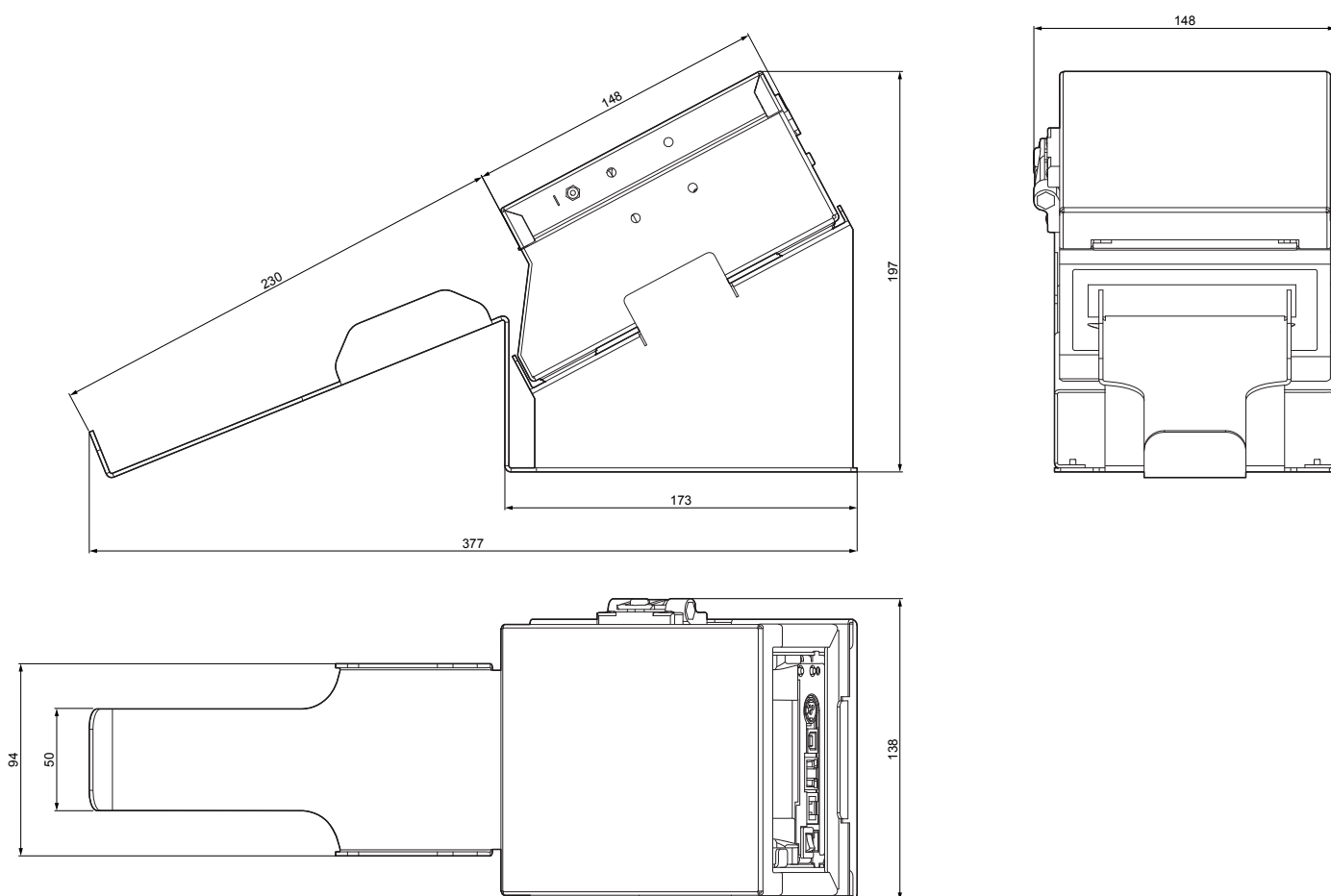



# 9.9 Dimensions of power supply and power cord

The following table shows the dimensions (in millimeters) of power supply unit and power cords available for the device.

<b>POWER SUPPLY code 963GE020000071</b> (optional for KPM180H 1, KPM180H 2, KPM180H 3, KPM180H 4, KPM180H 5, KPM180H 6)	
Length	130 mm
Height	36 mm
Width	57 mm
<b>POWER CORD WITH SHUKO PLUG code 26100000000311</b> (optional for every model)	
Length	2000 mm
<b>POWER CORD WITH UK PLUG code 26100000000313</b> (optional for every model)	
Length	2000 mm

## POWER SUPPLY code 963GE020000071

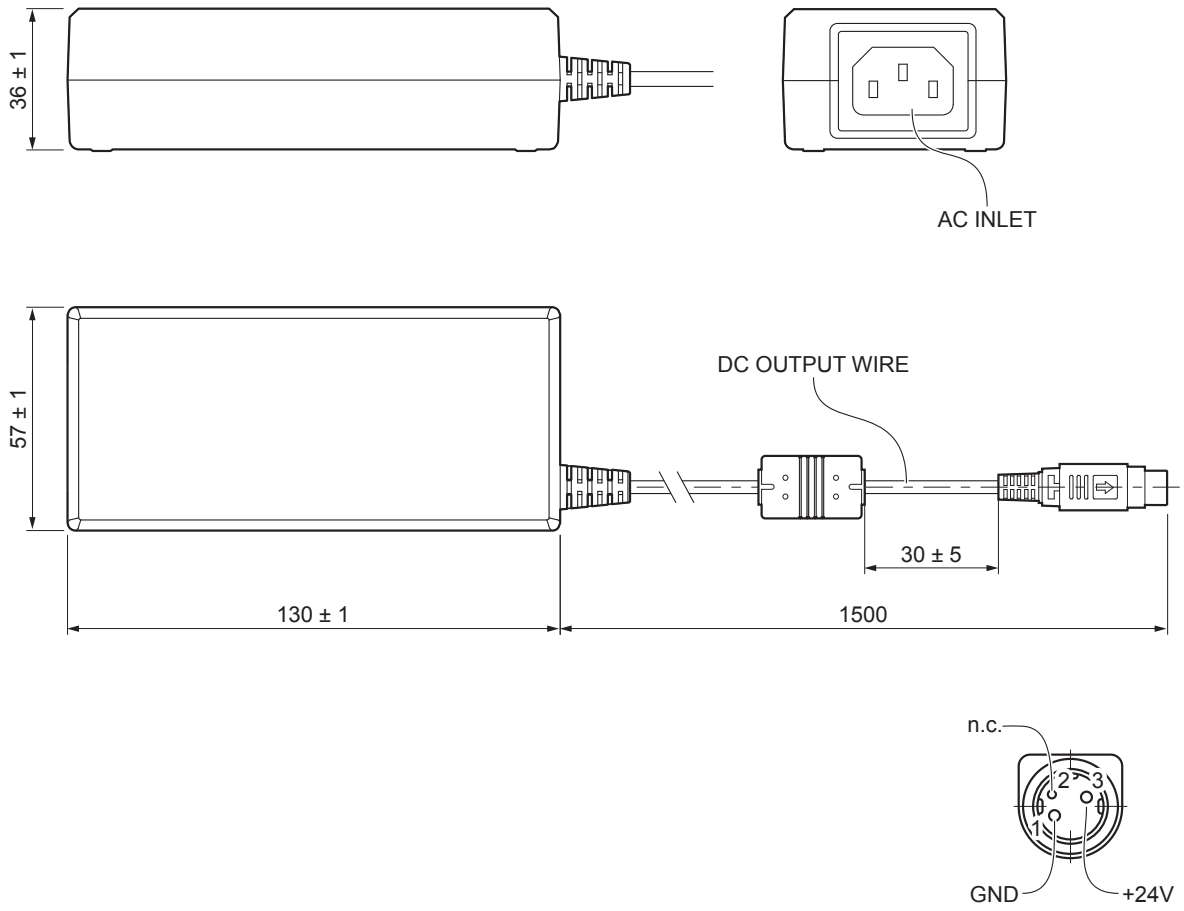



**POWER CORD code 2610000000311**

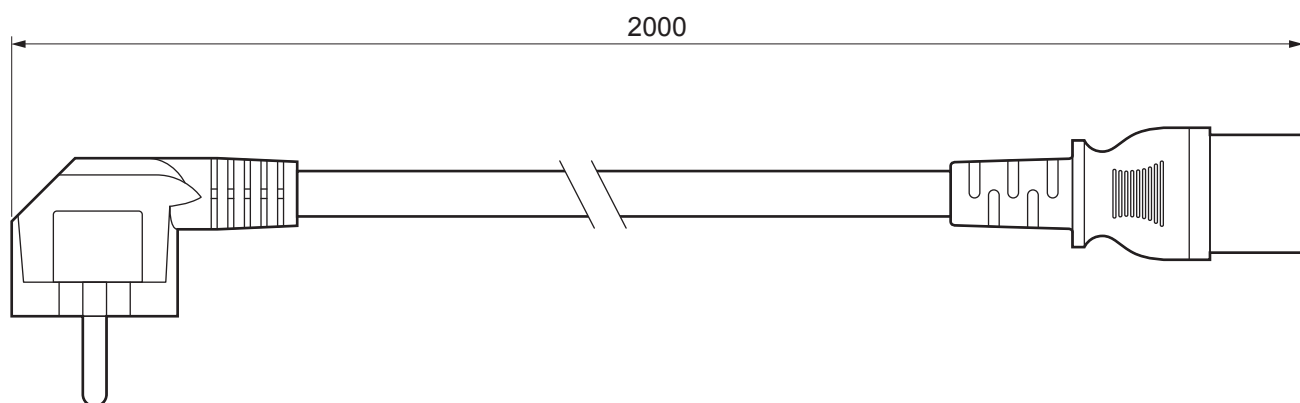

**POWER CORD code 2610000000313**

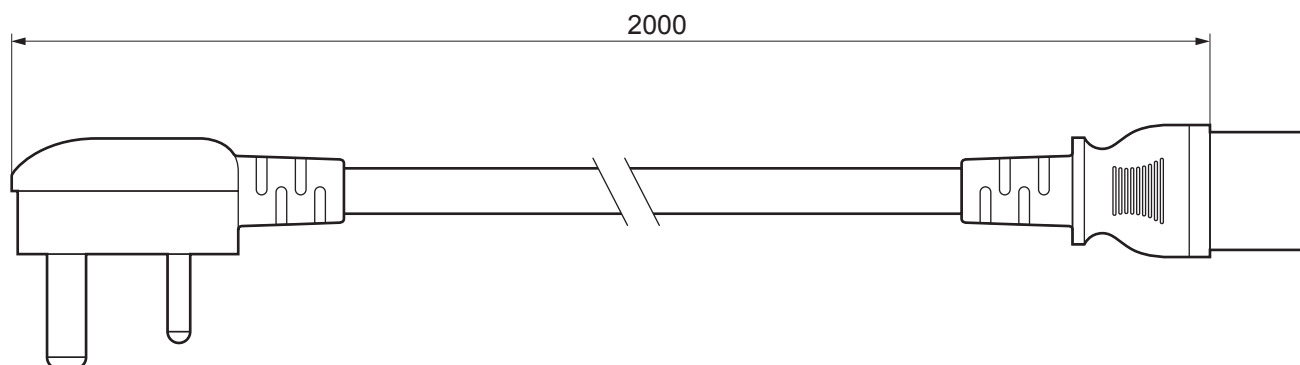

## 9.10 Paper specification

### Paper with black mark

The following image shows the placement of the black mark on paper (dimensions in millimeters). The black mark can be printed both on the thermal side and on the non-thermal side of paper and it can be placed anywhere on the whole width of the paper.

For more information about the use of paper with black mark see [chapter 7](#).

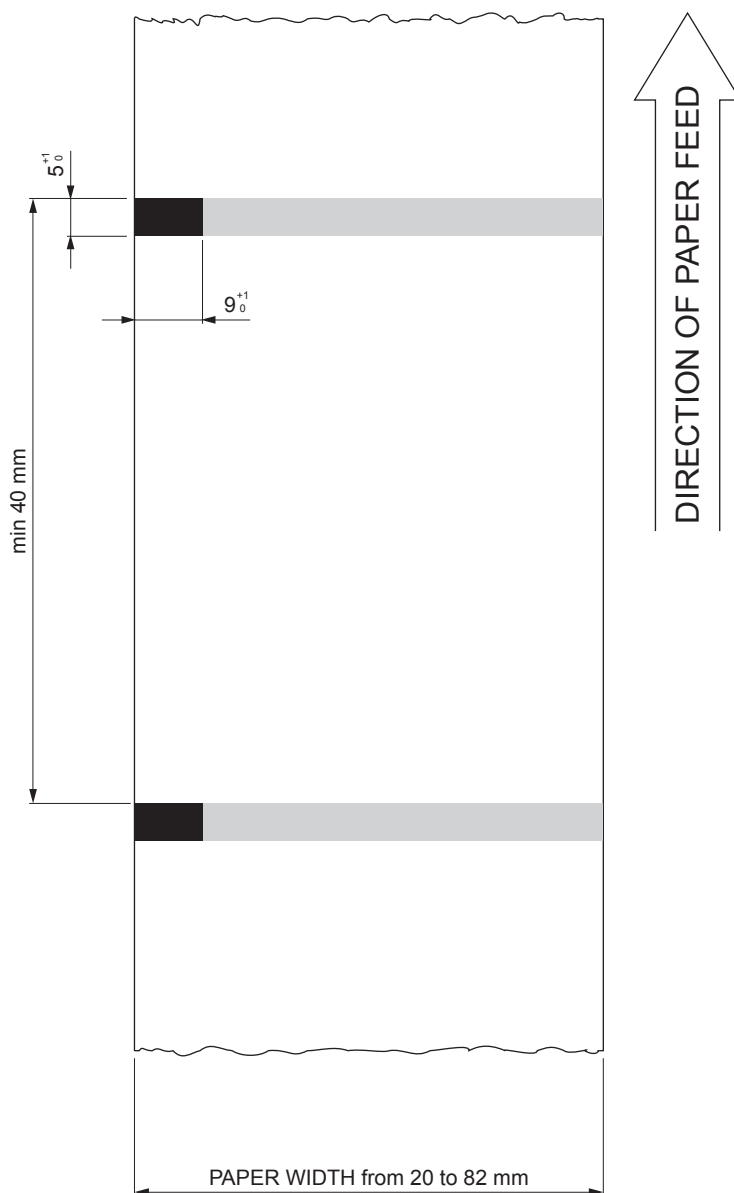



### **Fan-fold paper with hole**

The following image shows the placement of the hole on the paper (dimensions in millimeters). The hole can be positioned across the width of the ticket.

To manage tickets with hole, set the parameter “Black mark position” on the value “Transparent” (see [paragraph 6.8](#)). For more information about the use of paper with hole see [chapter 7](#).

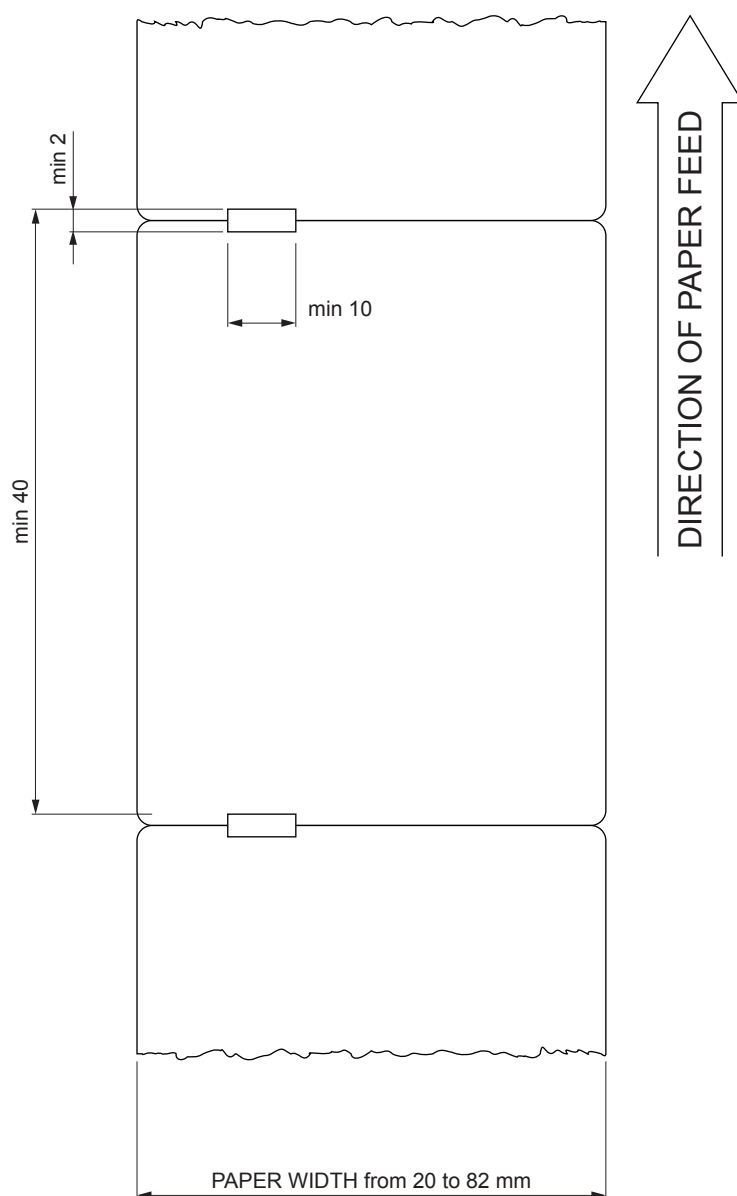

### **Ticket with RFID tag**

RFID (acronym for Radio Frequency Identification) is a technology to identify automatically items using radio waves; this system is based on wireless data capture from RFID tag using appropriate readers. The RFID tag, or transponder, is made up of :

- the microchip that stores the data (including also a unique serial number written);
- an RFID antenna.

The device models equipped with RFID reader are equipped with an RFID transceiver, provided with antenna, that allows to send and receive RF data to and from the tag. For this application the ticket dimensions are not binding but for good reading is important that the tag inside the ticket, after alignment, intersects the antenna area (see the following figure).

### **KPM180H 3, KPM180H 5**

### **TK180 MET 2**

### **TK180 CUT 2**

### **TK180 PLAS 2**

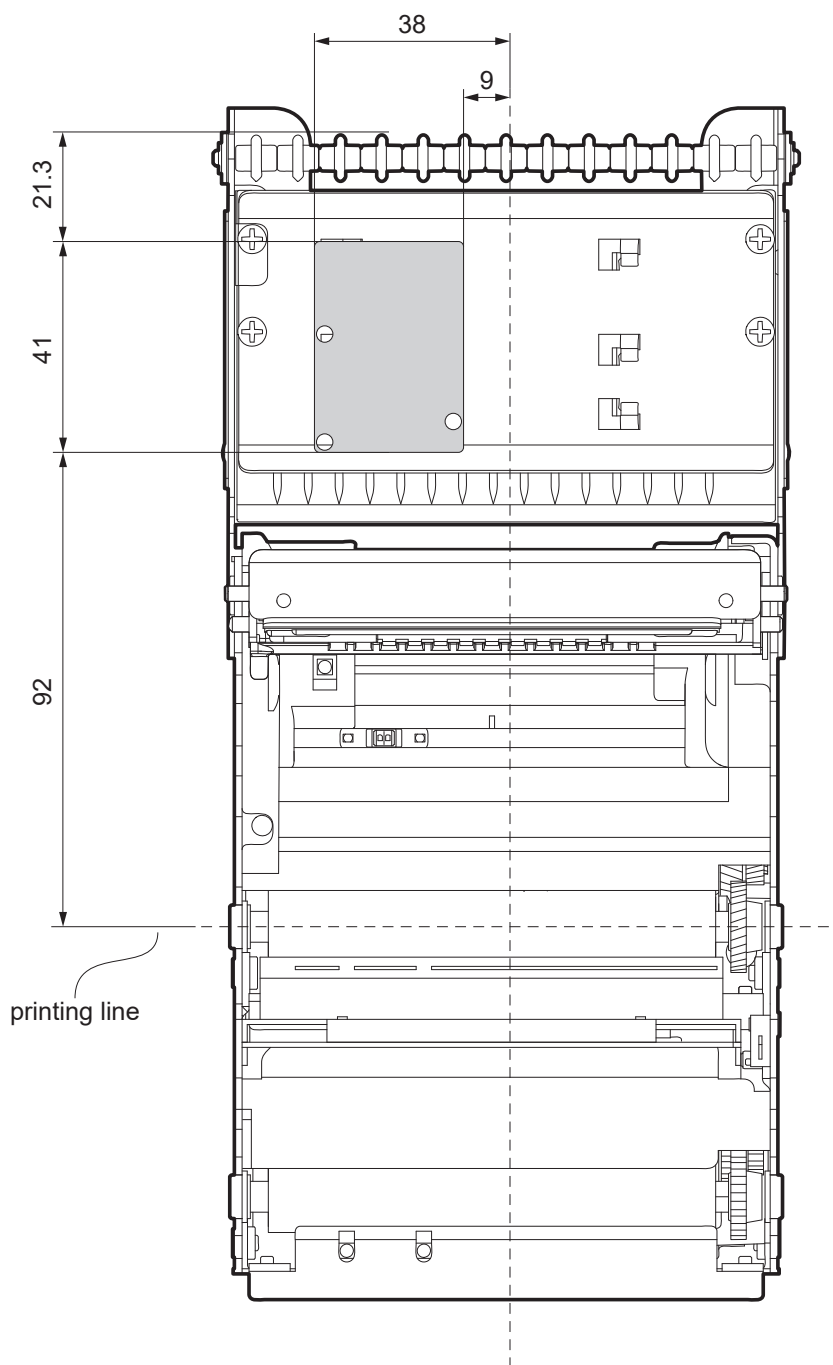



**KPM180H 6**  
**TK180 MET 3**  
**TK180 CUT 3**  
**TK180 PLAS 3**

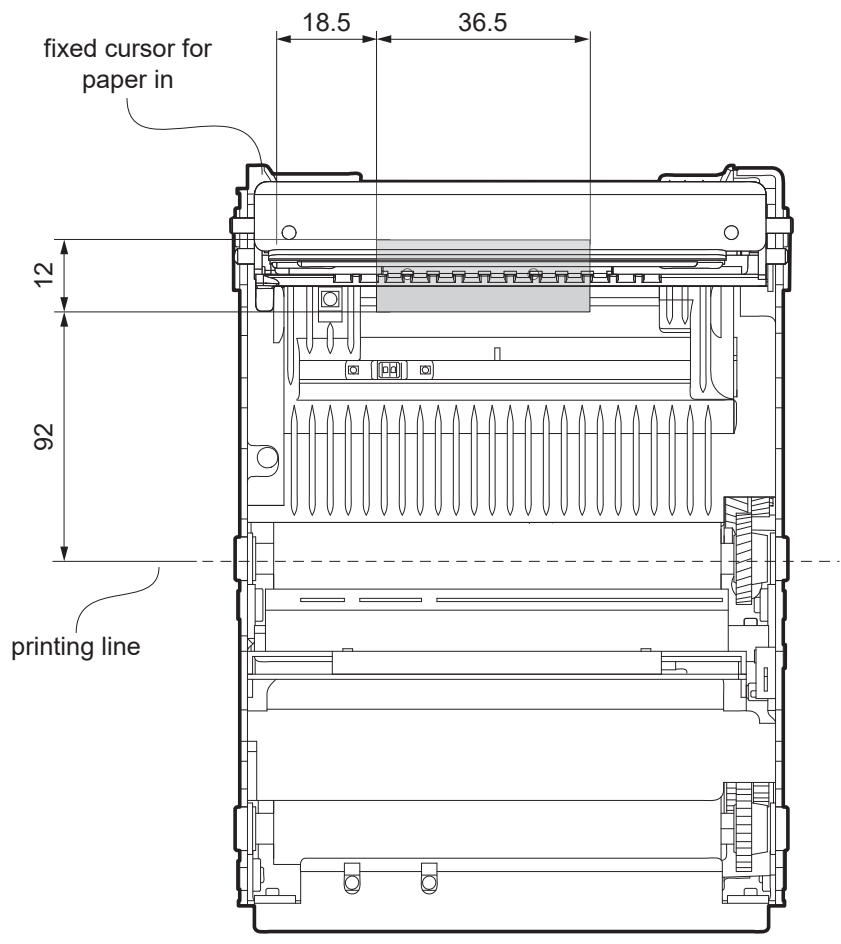



## 9.11 Character sets in CUSTOM/POS emulation

The device has 3 fonts of varying width (11, 15 and 20 cpi) which may be related one of the coding tables provided on the device.

To know the coding tables actually present on the device, you need to print the font test (see [paragraph 3.6](#)).

You can set font and coding table by using the commands (refer to the commands manual of the device) or using the "Code Table" and the "Chars / Inch" parameters during the setup procedure (see [paragraph 6.7](#)).

The following is the full list of coding tables that can be installed on the device.

<CodeTable>	Coding table	
0	PC437 - U.S.A., Standard Europe	
1	Katakana	
2	PC850 - Multilingual	
3	PC860 - Portuguese	
4	PC863 - Canadian/French	
5	PC865 - Nordic	
11	PC851 - Greek	on request
12	PC853 - Turkish	on request
13	PC857 - Turkish	on request
14	PC737 - Greek	on request
15	ISO8859-7 - Greek	on request
16	WPC1252	
17	PC866 - Cyrillic 2	
18	PC852 - Latin 2	on request
19	PC858 for Euro symbol in position 213	
20	KU42 - Thai	on request
21	TIS11 - Thai	on request
26	TIS18 - Thai	on request
30	TCVN_3 - Vietnamese	on request
31	TCVN_3 - Vietnamese	on request
32	PC720 - Arabic	on request
33	WPC775 - Baltic Rim	on request



<CodeTable>	Coding table	
34	PC855 - Cyrillic	on request
35	PC861 - Icelandic	on request
36	PC862 - Hebrew	
37	PC864 - Arabic	
38	PC869 - Greek	on request
39	ISO8859-2 - Latin 2	on request
40	ISO8859-15 - Latin 9	on request
41	PC1098 - Farci	on request
42	PC1118 - Lithuanian	on request
43	PC1119 - Lithuanian	on request
44	PC1125 - Ukrainian	on request
45	WPC1250 - Latin 2	
46	WPC1251 - Cyrillic	
47	WPC1253 - Greek	
48	WPC1254 - Turkish	
49	WPC1255 - Hebrew	
50	WPC1256 - Arabic	
51	WPC1257 - Baltic Rim	
52	WPC1258 - Vietnamese	
53	KZ1048 - Kazakhstan	on request
255	Space page	

In CUSTOM/POS emulation, it is possible to use TrueType fonts. To be used, a TrueType font must be monospace type (every character of the font must have the same dimension). The check is made by the device when the font is selected.

TrueType fonts will be automatically scaled by the device in order to obtain the same available width for the embedded fonts (11, 15 and 20 cpi).

The quality of TrueType fonts, the correct positioning into the printable area and the available code tables, will result from the font producers and the font implementation.

For the correct printing of the code tables, it is necessary that the selected TrueType font contains all the characters in the tables. Otherwise, the '□' symbol will be printed instead the missing character. All commands for printing configuration are usable both with TrueType fonts and with embedded fonts. It is possible to address the TrueType font respects the UNICODE standard (see [www.unicode.org](http://www.unicode.org)), by using UTF-8 or UTF-16 encoding.



## 9.12 Character sets in SVELTA emulation

In SVELTA emulation, the device has 20 embedded fonts of varying width which may be accessed through control characters (refer to the commands manual of the device). The following list shows the font available and relative dimensions in dot.

- Font HEL8PT8 <sup>(A)</sup> Proportional Font with fixed height (H = 28 dot)
- Font HEL10PT8 <sup>(A)</sup> Proportional Font with fixed height (H = 34 dot)
- Font HEL14PT8 <sup>(A)</sup> Proportional Font with fixed height (H = 50 dot)
- Font HEL16PT8 <sup>(A)</sup> Proportional Font with fixed height (H = 55 dot)
- Font 18x24 (Font 18x24 in CUSTOM/POS emulation)
- Font 14x24 (Font 14x24 in CUSTOM/POS emulation)
- Font 10x24 (Font 10x24 in CUSTOM/POS emulation)
- Font 8x12 <sup>(B)</sup> Fixed Font
- Font 8x12-2 <sup>(B)</sup> Fixed Font
- Font 12x12 <sup>(B)</sup> Fixed Font
- Font 14x11 <sup>(B)</sup> Fixed Font
- Font 16x24 <sup>(B)</sup> Fixed Font
- Font 16x24\_1 <sup>(B) (C)</sup> Fixed Font
- Font 16x24\_2 <sup>(B) (C)</sup> Fixed Font
- Font 20x15 <sup>(B)</sup> Fixed Font
- Font 28x20 <sup>(B)</sup> Fixed Font
- Font 14x24\_1 <sup>(B) (C)</sup> Fixed Font
- Font 16x24CN <sup>(B) (C)</sup> Fixed Font
- Font OCRB (20x32) <sup>(B)</sup> Fixed Font

For further information to characters representations print the Font Test (see [paragraph 3.6](#)).

In SVELTA emulation, it is possible to use TrueType fonts. True Type fonts are printable with every angle of rotation and in bold, reverse, italic and underlined mode.

It is possible to address the TrueType font respects the UNICODE standard (see [www.unicode.org](http://www.unicode.org)), by using UTF-8 or UTF-16 encoding.

For the correct printing of the code tables, it is necessary that the selected TrueType font contains all the characters in the tables. Otherwise, the '□' symbol will be printed instead the missing character.

### NOTES:

<sup>(A)</sup> A proportional font is a font in which different characters have different pitches (widths).

<sup>(B)</sup> A fixed font is the opposite of a proportional font and is a fixed-pitch font.

<sup>(C)</sup> The fonts with the same name and dimension contain different characters in different positions from theirs.



# 10 CONSUMABLES

The following tables show the list of the available consumables for the devices.

## KPM180H 1, KPM180H 2

**67300000000415**

THERMAL PAPER ROLL

width = 82.5 mm  
external diameter = 150 mm  
weight = 70 g/m<sup>2</sup>

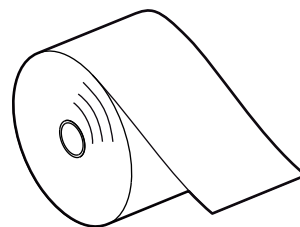

## KPM180H 1, KPM180H 2, KPM180H 3 TK180 MET 1, TK180 MET 2 TK180 CUT 1, TK180 CUT 2 TK180 PLAS 1, TK180 PLAS 2

**67A00000000304**

FAN-FOLD (100 tickets)

weight = 140 g/m<sup>2</sup>  
dimensions = 152mm x 80mm

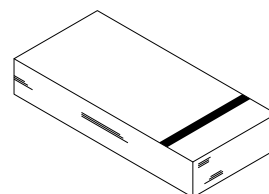





# 11 ACCESSORIES

The following tables show the list of the available accessories for the devices.

## KPM180H 1, KPM180H 2

---

**976AH030000001**

PRETENSIONER MODULE LINERLESS

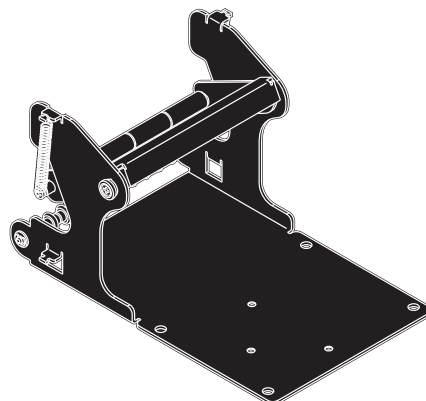

## KPM180H 2, KPM180H 4 TK180 MET 1, TK180 PLAS 1

---

**918HL020200000**

RFID MODULE

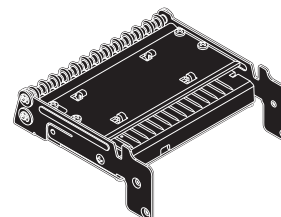



**KPM180H 1, KPM180H 2, KPM180H 3**  
**KPM180H 4, KPM180H 5, KPM180H 6**

---

**963GE020000071**

POWER SUPPLY  
(for technical specifications, see [paragraph 9.1](#))

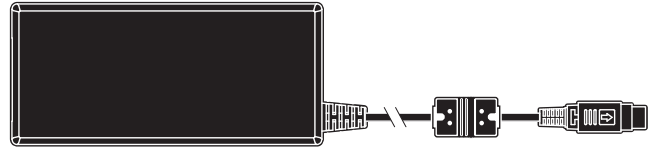

**26100000000311**

MAINS CABLE SHUKO PLUG  
length = 2 m



**26100000000313**

MAINS CABLE UK PLUG  
length = 2 m



**26900000000026**

ADAPTER CABLE RJ45M-DB9F  
length = 0.1 m



**26500000000352**

SERIAL CABLE DB9M-DB9F  
length = 1.8 m



**26500000000356**

USB CABLE TYPE A-B  
length = 1.8 m





**TK180 MET 1, TK180 MET 3**

---

**974HL010000010**

ATB TICKET TRAY

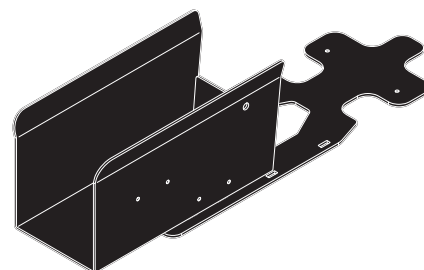

**974HL010000011**

SHAFT FOR ATB TICKET TRAY  
(only for models with ATB ticket tray  
cod. 974HL010000010)

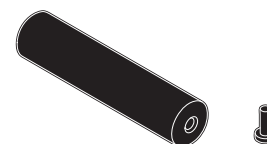

**TK180 MET 1, TK180 MET 2**  
**TK180 CUT 2, TK180 CUT 3**

---

**26900000000026**

ADAPTER CABLE RJ45M-DB9F  
length = 0.1 m



**261000000000313**

MAINS CABLE UK PLUG  
length = 2 m



**974HL010000009**

PAPER ROLL HOLDER

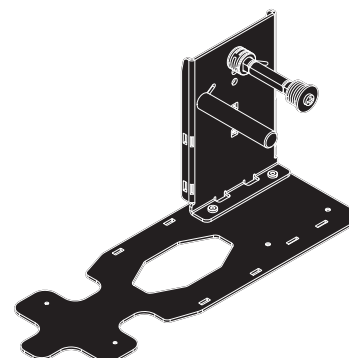



**TK180 CUT 1, TK180 CUT 3**

---

**26900000000026**

ADAPTER CABLE RJ45M-DB9F  
length = 0.1 m



**261000000000313**

MAINS CABLE UK PLUG  
length = 2 m



**974HL010000009**

PAPER ROLL HOLDER

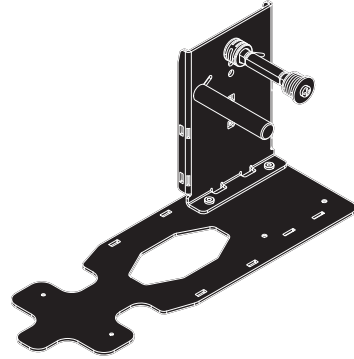

**974HL010000010**

ATB TICKET TRAY  
rear mounting

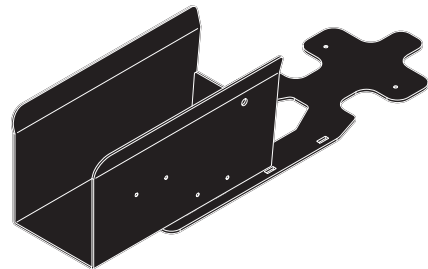

**976HL010000007**

ATB TICKET TRAY  
front mounting

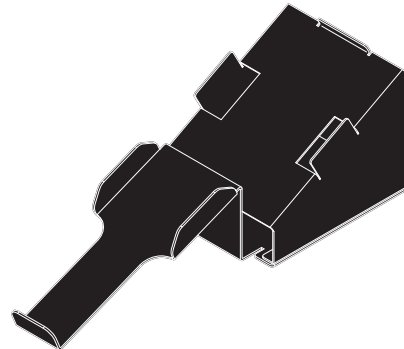



**974HL010000011**

SHAFT FOR ATB TICKET TRAY  
(only for models with ATB ticket tray  
cod. 974HL010000010)

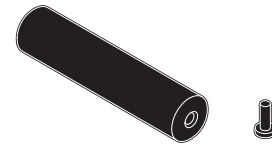

**TK180 PLAS 1, TK180 PLAS 2, TK180 PLAS 3**

**26900000000026**

ADAPTER CABLE RJ45M-DB9F  
length = 0.1 m



**265000000000352**

SERIAL CABLE DB9M-DB9F  
length = 1.8 m



**265000000000356**

USB CABLE TYPE A-B  
length = 1.8 m



**261000000000313**

MAINS CABLE UK PLUG  
length = 2 m



**974HL020000006**

PAPER ROLL HOLDER

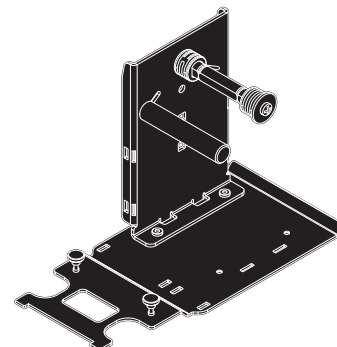





# 12 TECHNICAL SERVICE

In case of failure, contact the technical service accessing the website [www.custom4u.it](http://www.custom4u.it) and using the support tools on the home page. It is advisable to keep the identification data of the product at hand.

The product code, the serial number and the hardware release number can be found on the two product labels (see [paragraph 3.5](#)).

The firmware release number (SCODE) can be found:

- on the setup report (see [paragraph 6.1](#)),
- connecting the device to a PC and starting the “PrinterSet” tool (see [paragraph 6.2](#)),
- by consulting the “setup.ini” ( see [paragraph 6.3](#)).

**CUSTOM<sup>®</sup>**

**CUSTOM S.p.A.**

World Headquarters

**Via Berettine, 2/B - 43010 Fontevivo, Parma ITALY**

**Tel. +39 0521 680111 - Fax +39 0521 610701**

**info@custom.biz - www.custom.biz**

*All rights reserved*