

USER MANUAL

TG02H

CUSTOM[®]

CUSTOM S.p.A.
Via Berettine 2/B
43010 Fontevivo (PARMA) - Italy
Tel. : +39 0521-680111
Fax : +39 0521-610701
http: www.custom.biz

Customer Service Department:
Email : support@custom.it

© 2014 CUSTOM S.p.A. – Italy.
All rights reserved. Total or partial reproduction of this manual in whatever form, whether by printed or electronic means, is forbidden. While guaranteeing that the information contained in it has been carefully checked, CUSTOM S.p.A. and other entities utilized in the realization of this manual bear no responsibility for how the manual is used.
Information regarding any errors found in it or suggestions on how it could be improved are appreciated. Since products are subject to continuous check and improvement, CUSTOM S.p.A. reserves the right to make changes in information contained in this manual without prior notification.

The pre-installed multimedia contents are protected from Copyright CUSTOM S.p.A. Other company and product names mentioned herein may be trademarks of their respective companies. Mention of third-party products is for informational purposes only and constitutes neither an endorsement nor a recommendation. CUSTOM S.p.A. assumes no responsibility with regard to the performance or use of these products.

THE IMAGES USED IN THIS MANUAL ARE USED AS AN ILLUSTRATIVE EXAMPLES. THEY COULDN'T REPRODUCE THE DESCRIBED MODEL FAITHFULLY.

UNLESS OTHERWISE SPECIFIED, THE INFORMATION GIVEN IN THIS MANUAL ARE REFERRED TO ALL MODELS IN PRODUCTION AT THE ISSUE DATE OF THIS DOCUMENT.



The format used for this manual improves use of natural resources reducing the quantity of necessary paper to print this copy.

GENERAL SAFETY INFORMATION

Your attention is drawn to the following actions that could compromise the characteristics of the product:

- Read and retain the instructions which follow.
 - Follow all indications and instructions given on the device.
 - Make sure that the surface on which the device rests is stable. If it is not, the device could fall, seriously damaging it.
 - Make sure that the device rests on a hard (non-padded) surface and that there is sufficient ventilation.
 - When positioning the device, make sure cables do not get damaged.
 - Use the type of electrical power supply indicated on the device label. If uncertain, contact your dealer.
 - Make sure the electrical system that supplies power to the device is equipped with a ground wire and is protected by a differential switch.
 - Do not block the ventilation openings.
 - Do not insert objects inside the device as this could cause short-circuiting or damage components that could jeopardize printer functioning.
 - Do not carry out repairs on the device yourself, except for the normal maintenance operations given in the user manual.
 - Make sure that there is an easily-accessible outlet with a capacity of no less than 10A closely to where the device is to be installed.
 - Periodically perform scheduled maintenance on the device to avoid dirt build-up that could compromise the correct, safe operation of the unit.
 - Before any type of work is done on the machine, disconnect the power supply.
 - Do not touch the head heating line with bare hands or metal objects. Do not perform any operation inside the printer immediately after printing because the head and motor tend to become very hot.
- GENERAL INSTRUCTIONS
CUSTOM S.p.A. declines all responsibility for accidents or damage to persons or property occurring as a result of tampering, structural or functional modifications, unsuitable or incorrect installations, environments not in keeping with the equipment's protection degree or with the required temperature and humidity conditions, failure to carry out maintenance and periodical inspections and poor repair work.



THE CE MARK AFFIXED TO THE PRODUCT CERTIFY THAT THE PRODUCT SATISFIES THE BASIC SAFETY REQUIREMENTS.

The device is in conformity with the essential Electromagnetic Compatibility and Electric Safety requirements laid down in Directives 2006/95/CE and 2004/108/CE inasmuch as it was designed in conformity with the provisions laid down in the following Standards:

- EN 55022 Class B (*Limits and methods of measurements of radio disturbance characteristics of Information Technology Equipment*)
- EN 55024 (*Information Technology Equipment – Immunity characteristics – Limits and methods of measurement*)
- EN 60950-1 (*Safety of information equipment including electrical business equipment*)



GUIDELINES FOR THE DISPOSAL OF THE PRODUCT

The crossed-out rubbish bin logo means that used electrical and electronic products shall NOT be mixed with unsorted municipal waste. For more detailed information about recycling of this product, refer to the instructions of your country for the disposal of these products.

- Do not dispose of this equipment as miscellaneous solid municipal waste, but arrange to have it collected separately.
- The re-use or correct recycling of the electronic and electrical equipment (EEE) is important in order to protect the environment and the wellbeing of humans.
- In accordance with European Directive WEEE 2002/96/EC, special collection points are available to which to deliver waste electrical and electronic equipment and the equipment can also be handed over to a distributor at the moment of purchasing a new equivalent type.
- The public administration and producers of electrical and electronic equipment are involved in facilitating the processes of the re-use and recovery of waste electrical and electronic equipment through the organisation of collection activities and the use of appropriate planning arrangements.
- Unauthorised disposal of waste electrical and electronic equipment is punishable by law with the appropriate penalties.

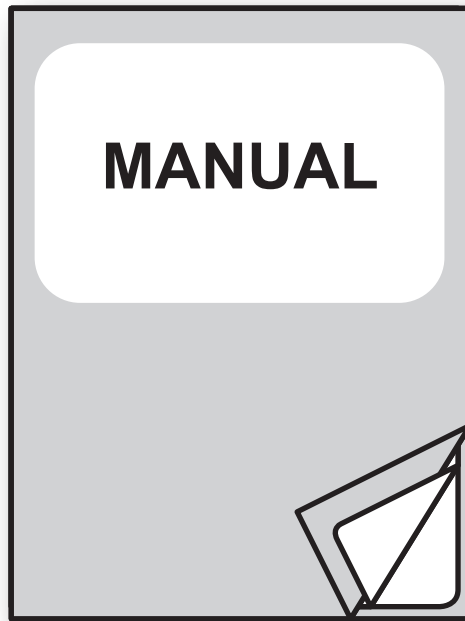

For details on the commands,
refer to the manual with code **77200000003000**

TABLE OF CONTENTS

1	INTRODUCTION	9
1.1	Document structure	9
1.2	Explanatory notes used in this manual	9
2	DESCRIPTION	11
2.1	Box content	11
2.2	Device components	13
2.3	Product label	15
2.4	Key functions: power up	16
2.5	Key functions: standby	17
2.6	Status led flashes	18
3	INSTALLATION	19
3.1	Fastening	19
3.2	Paper roll holder assembly	22
3.3	Connections	24
3.4	Pinout	25
3.5	Serial port setting	29
3.6	Driver and SDK	31
4	OPERATION	33
4.1	Switch the device ON	33
4.2	Loading the paper roll	34
4.3	Issuing ticket	36
5	CONFIGURATION	37
5.1	Configuration mode	37
5.2	Setup report	38
5.3	Printer status	39
5.4	Printer parameters	40
5.5	Hexadecimal dump	43
6	MAINTENANCE	45
6.1	Printer paper jam	45
6.2	Planning of cleaning operations	46
6.3	Cleaning	47
6.4	Upgrade firmware	49

7	SPECIFICATION	51
7.1	Hardware specifications	51
7.2	Character specifications in ESC/POS™ emulation	54
7.3	Device dimensions	55
7.4	Character sets in ESC/POS™ emulation	59
8	CONSUMABLES	61
9	ACCESSORIES	63
10	TECHNICAL SERVICE	65

1 INTRODUCTION

1.1 Document structure

This document includes the following chapters:

1	INTRODUCTION	information about this document
2	DESCRIPTION	general description of device
3	INSTALLATION	information required for a correct installation of the device
4	OPERATION	information required to make the device operative
5	CONFIGURATION	description of the configuration parameters of the device
6	MAINTENANCE	information for a correct periodic maintenance
7	SPECIFICATION	technical specification for the device and its accessories
8	CONSUMABLES	description and installation of the available consumables for the device
9	ACCESSORIES	description and installation of the available accessories for the device
10	TECHNICAL SERVICE	information required for contacting the technical service

1.2 Explanatory notes used in this manual

NOTE:

Gives important information or suggestions relative to the use of the device

ATTENTION:

Gives information that must be carefully followed to guard against damaging the device

DANGER:

Gives information that must be carefully followed to guard against operator injury or damage

2 DESCRIPTION

2.1 Box content

Remove the device from its carton being careful not to damage the packing material so that it may be re-used if the printer is to be transported in the future.

Make sure that all the components illustrated below are present and that there are no signs of damage. If there are, contact Customer Service.

Standard model

1. Device
2. Locking ring
3. Paper roll
4. Disks for the paper roll containment
5. Installation instruction sheet

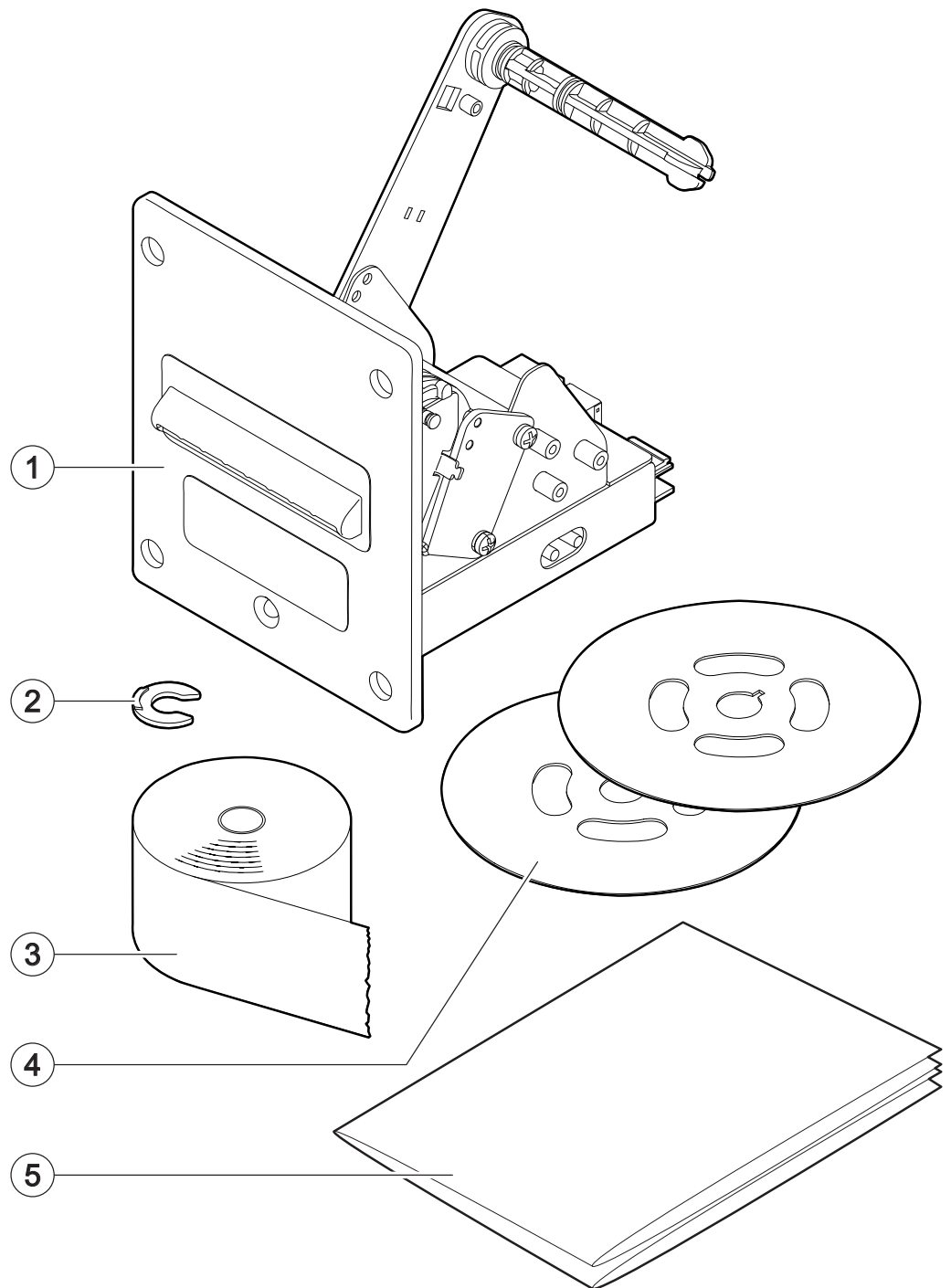

Model with illuminated paper bezel

1. Device
2. Locking ring
3. Paper roll
4. Disks for the paper roll containment
5. Installation instruction sheet

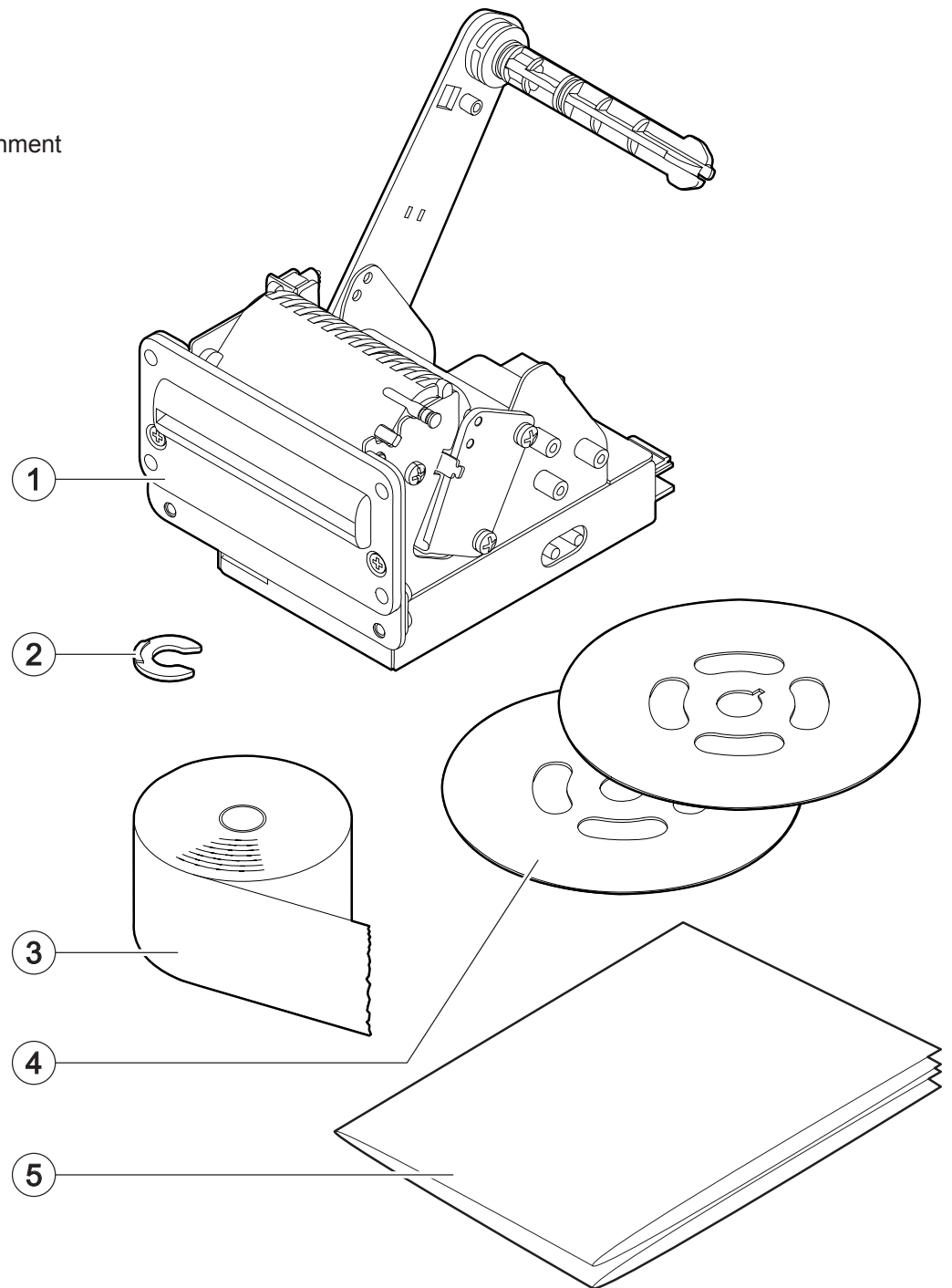

- Open the device packaging.
- Take out the device.
- Take out the rest of the content.
- Keep the box, trays and packing materials in the event the printer must be transported/shipped in the future.

2.2 Device components

Standard models

1. Paper out
2. Connector for near paper end sensor (external)
3. Status led
4. Power supply port
5. AUX port (optional)
6. USB port
7. RS232/TTL serial port
8. Serial RS232/TTL configuration
9. Device chassis
10. Sensor for paper detection
11. Paper jam sensor
12. Paper input
13. Inspection door
14. LF LINE FEED key
15. FF FORM FEED key
16. Paper roll holder

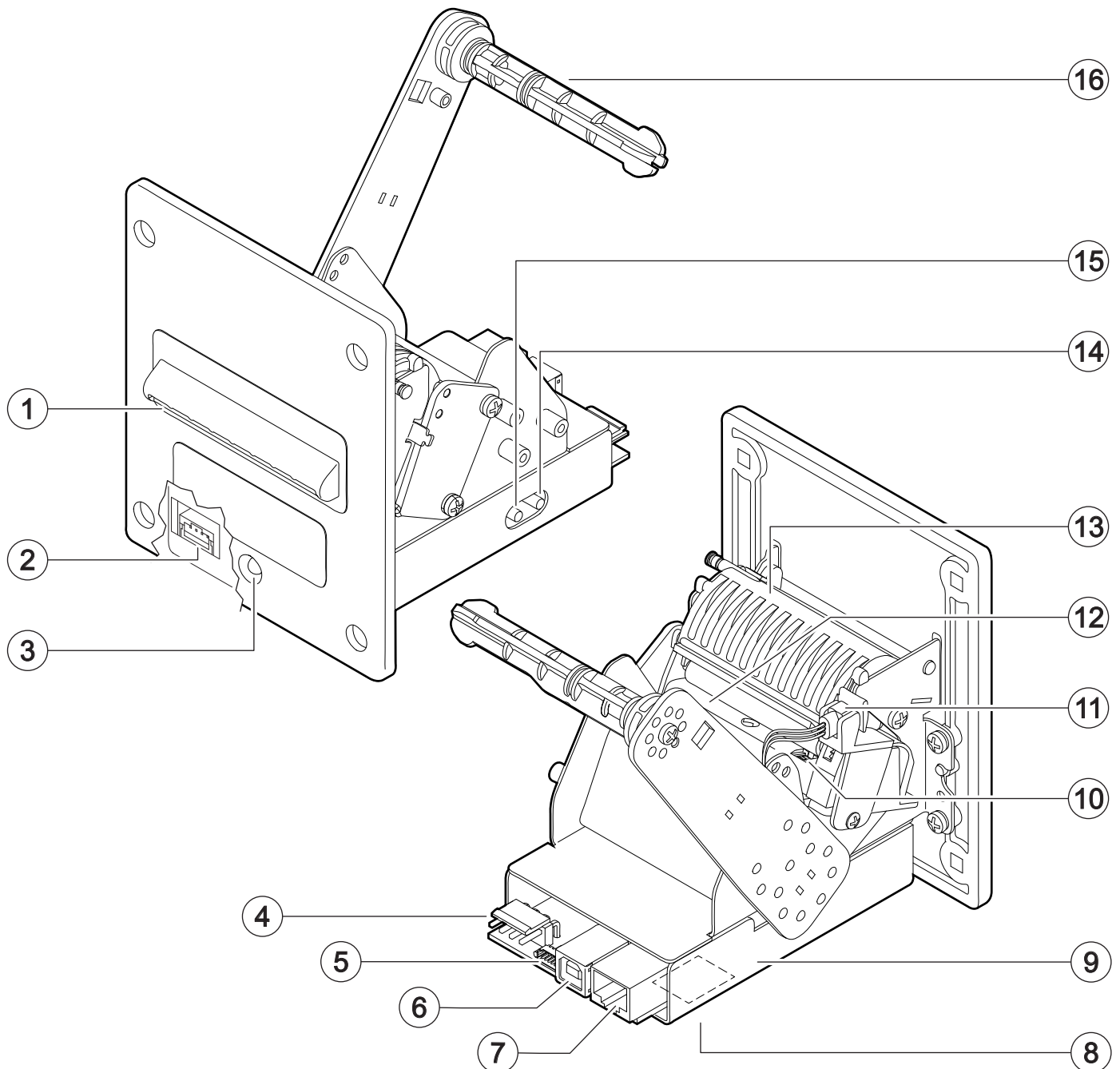

Model with illuminated paper bezel

1. Inspection door
2. Illuminated paper bezel
3. Paper out
4. Connector for near paper end sensor (external)
5. Power supply port
6. AUX port (optional)
7. USB port
8. RS232/TTL serial port
9. Serial RS232/TTL configuration
10. Device chassis
11. Sensor for paper detection
12. Paper jam sensor
13. Paper input
14. LF LINE FEED key
15. FF FORM FEED key
16. Paper roll holder

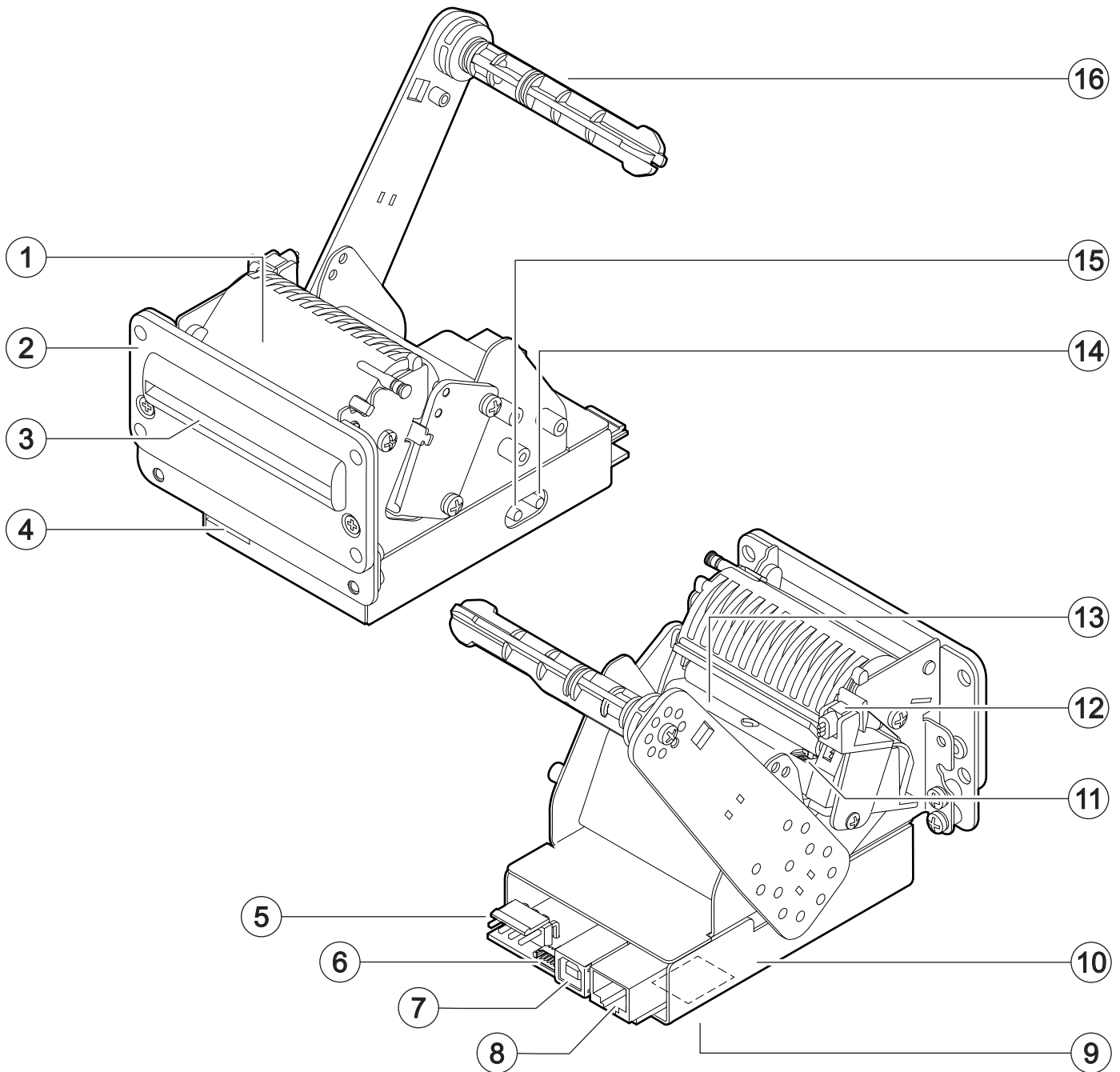

2.3 Product label

PC = Product code (14 digits)
SN = Serial number
HW = Hardware release

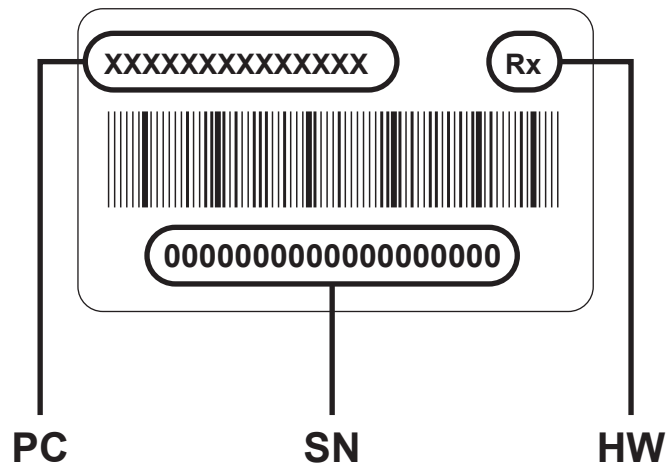

2.4 Key functions: power up

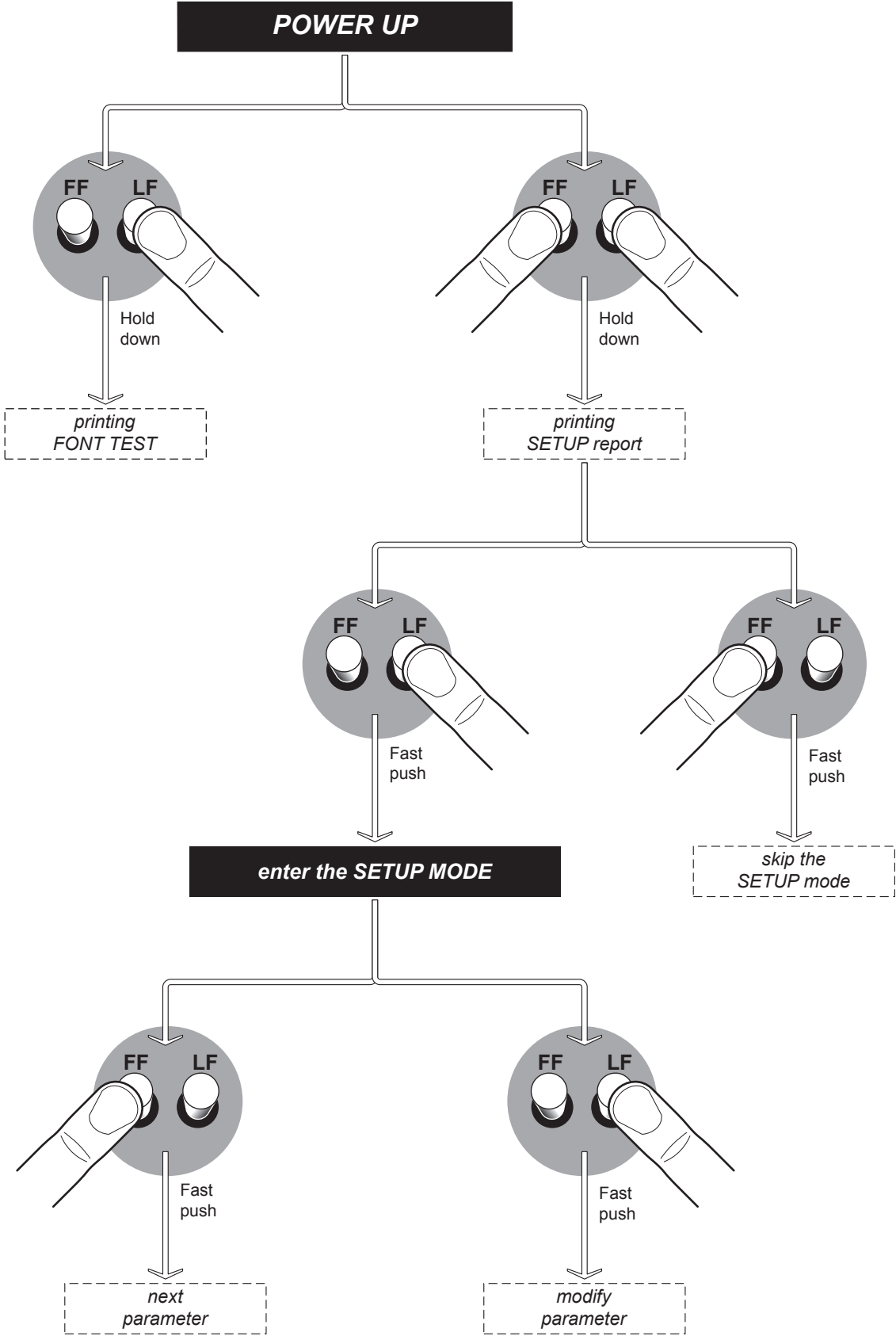

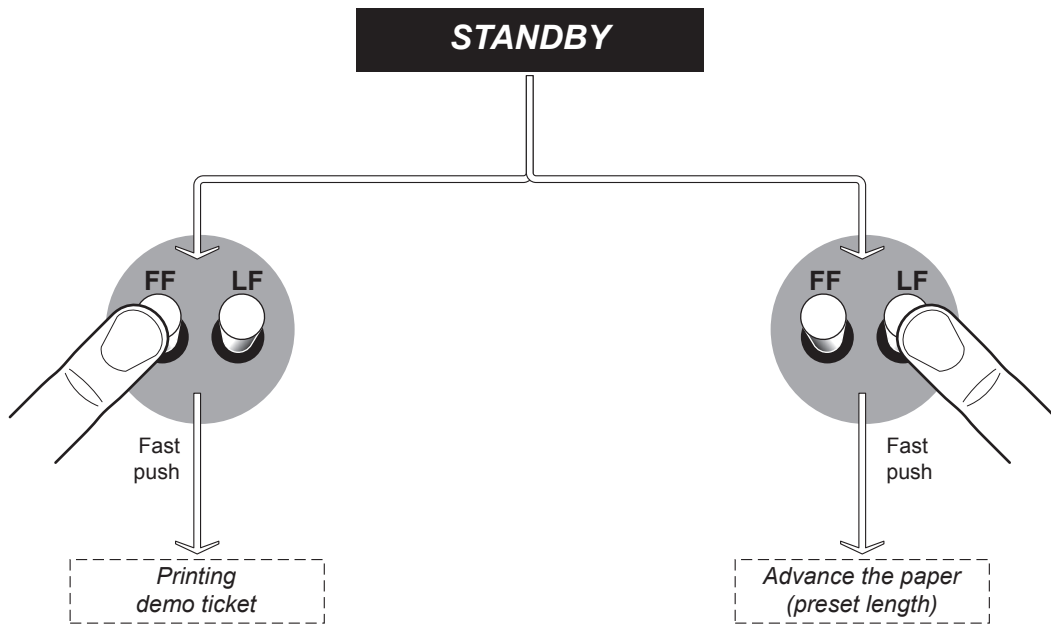

2.5 Key functions: standby



2.6 Status led flashes

The Status led indicates hardware status of device. Given in the table below are the various led signals and the corresponding device status.

STATUS LED		DESCRIPTION	
-		OFF	PRINTER OFF
GREEN (Standard model)		ON	PRINTER ON: NO ERROR
BLUE (Model with illuminated paper bezel)			
GREEN (Standard model) BLUE (Model with illuminated paper bezel)		x 2	HEADING OVER TEMPERATURE
		x 3	PAPER END
		x 4	POWER SUPPLY VOLTAGE INCORRECT
		x 5	RECEPTION ERRORS (PARITY, FRAME ERROR, OVERRUN ERROR)
		x 6	COMMAND NOT RECOGNIZED
		x 7	COMMAND RECEPTION TIME OUT
		x 8	INSPECTION DOOR OPEN
		x 9	PAPER JAM
		x 10	RECEIVING DATA

3 INSTALLATION

3.1 Fastening

Model with illuminated paper bezel

The device is provided with four fixing holes on the front of device (see following figure). To fasten the device on a panel, use four M3 screws by following the scheme A.

SCHEME A

Fixing on the rear side of the panel

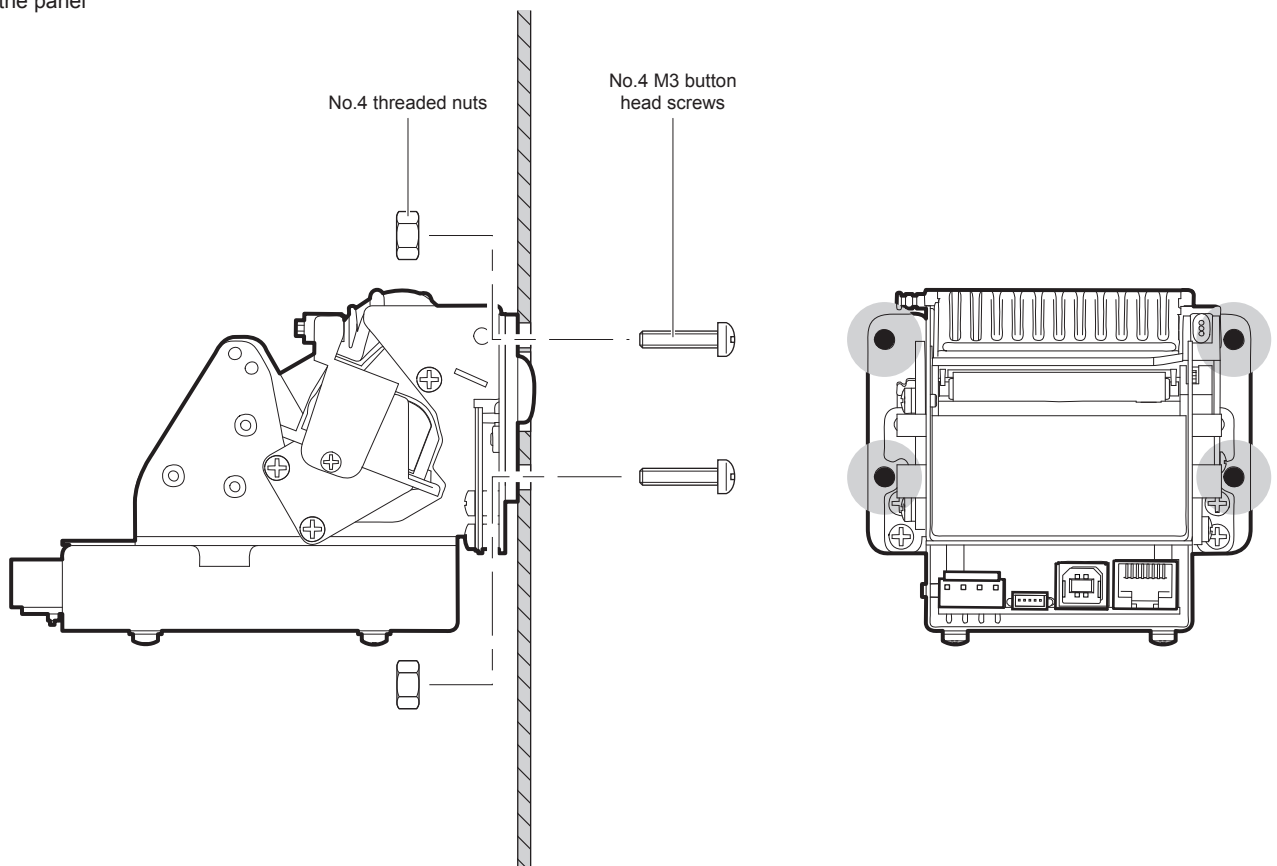

The drilling on the panel must comply with the measures shown in the following pages.

Standard model

The device is provided with four fixing holes on the front of device (see following figure). To fasten the device on a panel, use four M3 screws by following the schemes B or C.

SCHEME B

Fixing on the front side of the panel

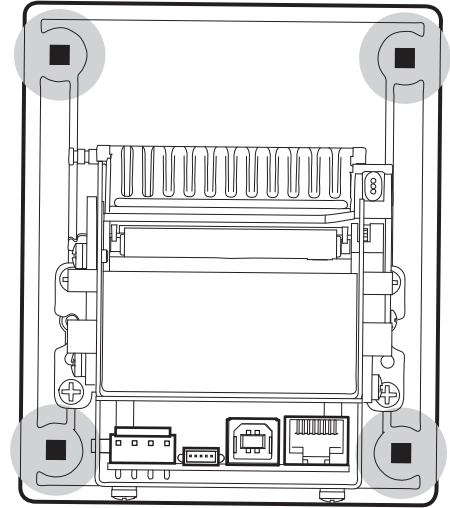
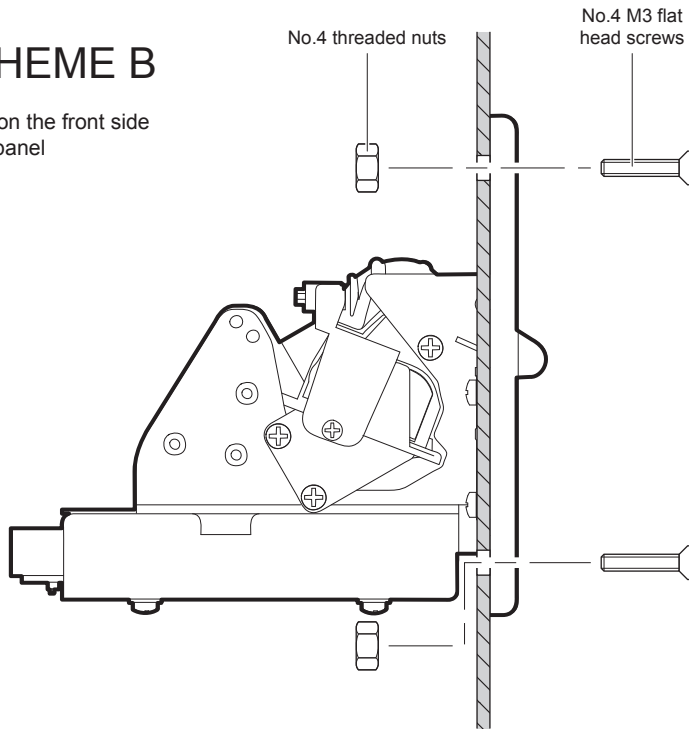

SCHEME C

Fixing on the rear side of the panel

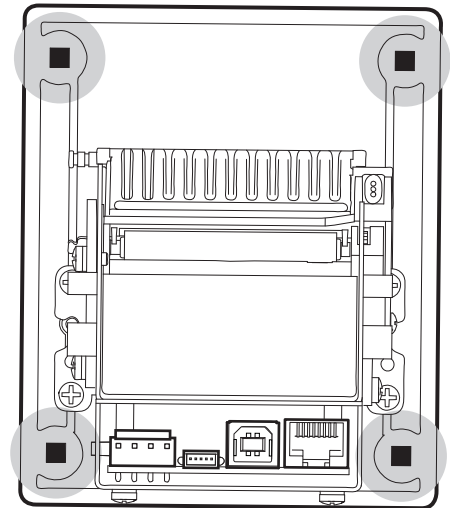
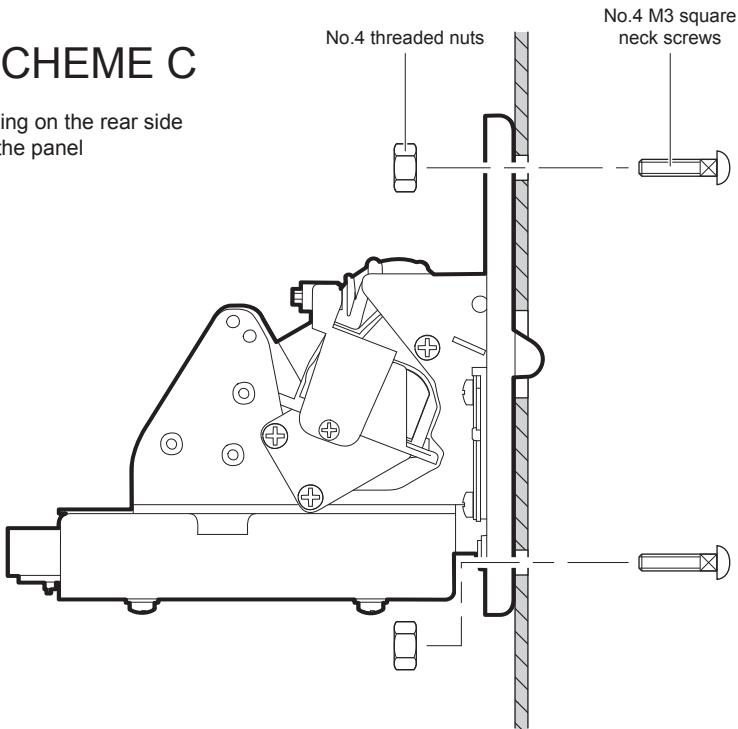

The drilling on the panel must comply with the measures shown in the following page.

3.2 Paper roll holder assembly

1

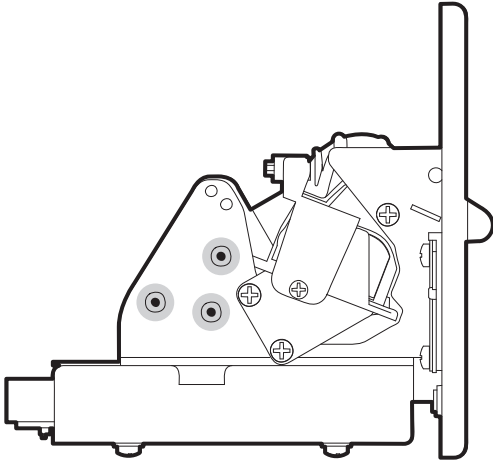

Left side

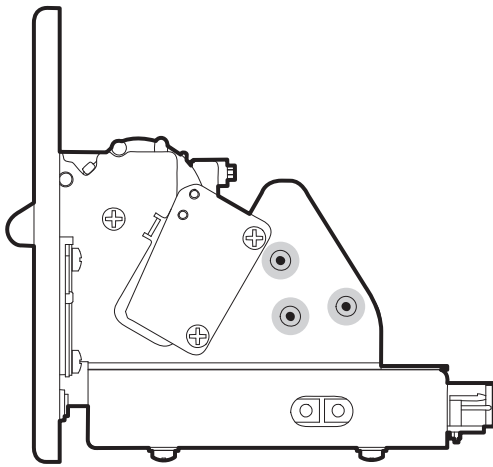

Right side

Use the three threaded inserts on the frame to secure the bracket in one of 5 positions illustrated on the next page. The bracket can be mounted on the right or on the left side of the device.

2

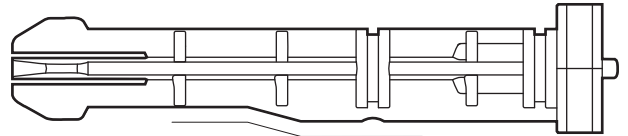
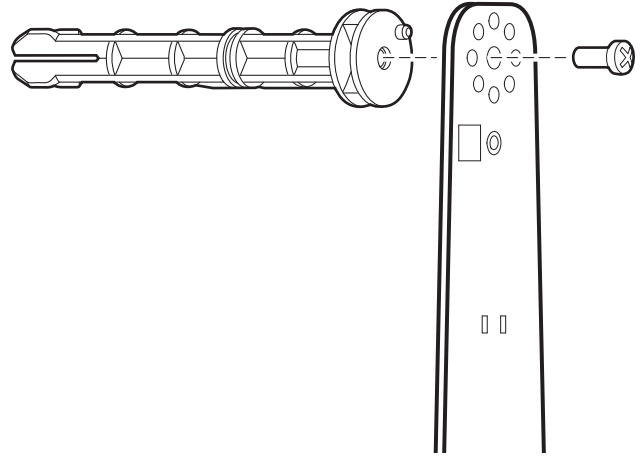

This side facing down

Fix the paper roll pin to the bracket with the supplied screw. Follow the assembly direction shown in the detail box.

3

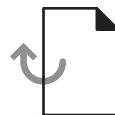

**SEE NEXT
PARAGRAPHS**

Load the paper roll following the instructions provided in the paragraph "Paper roll holder assembly".

Mounting positions (right side or left side)

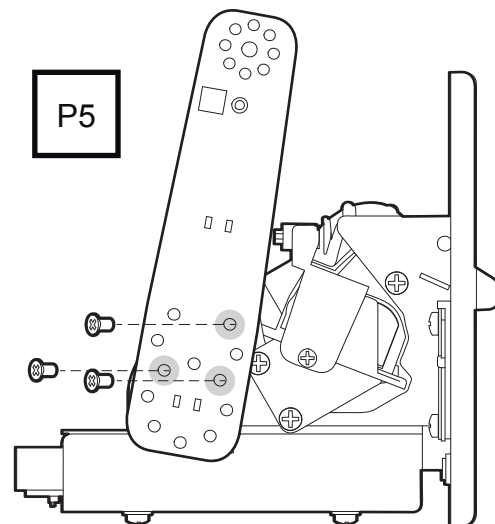
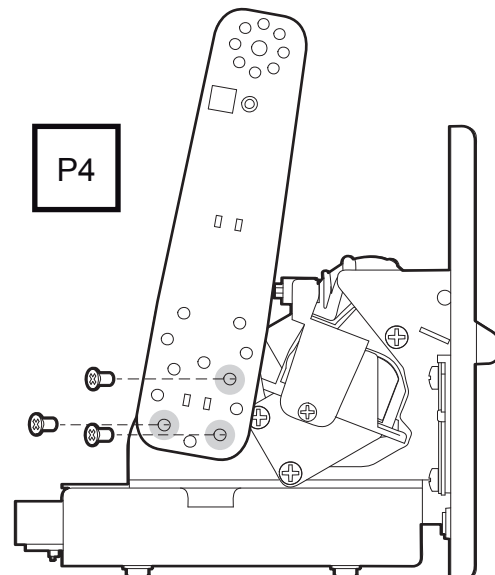
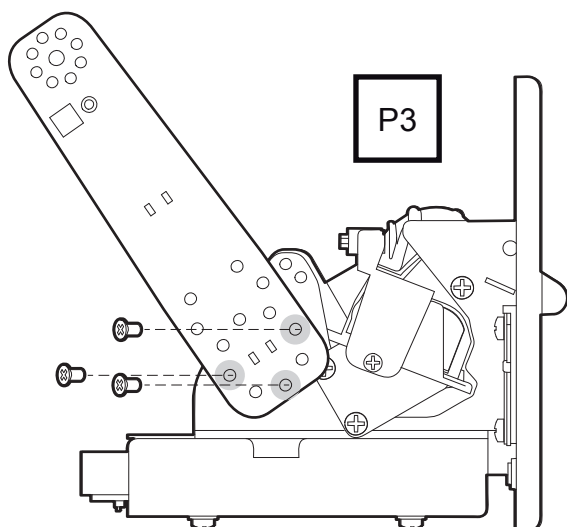
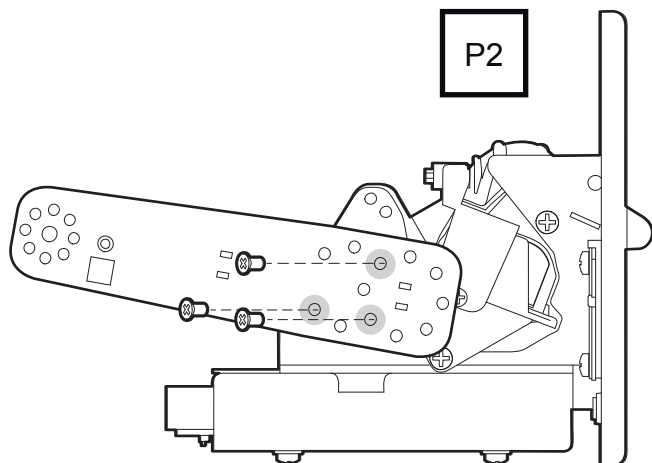
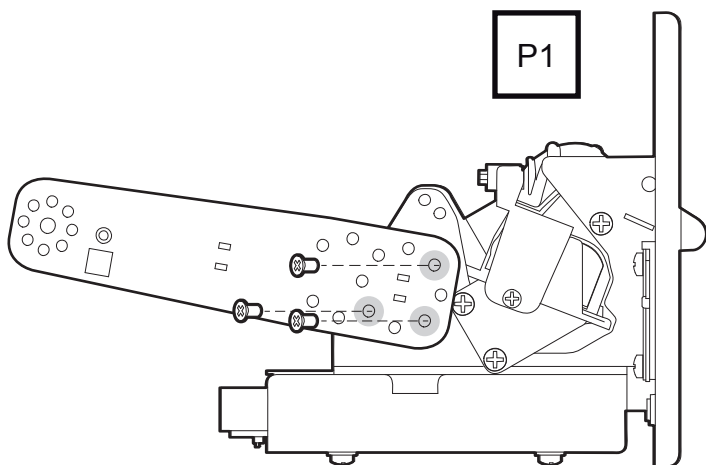

3.3 Connections

The following figure shows the possible connections for the device.

ATTENTION:

In some using conditions, we recommend the installation of a ferrite core on the power supply cable.

NOTE:

If RS232 and USB connectors are inserted, communication port is USB.

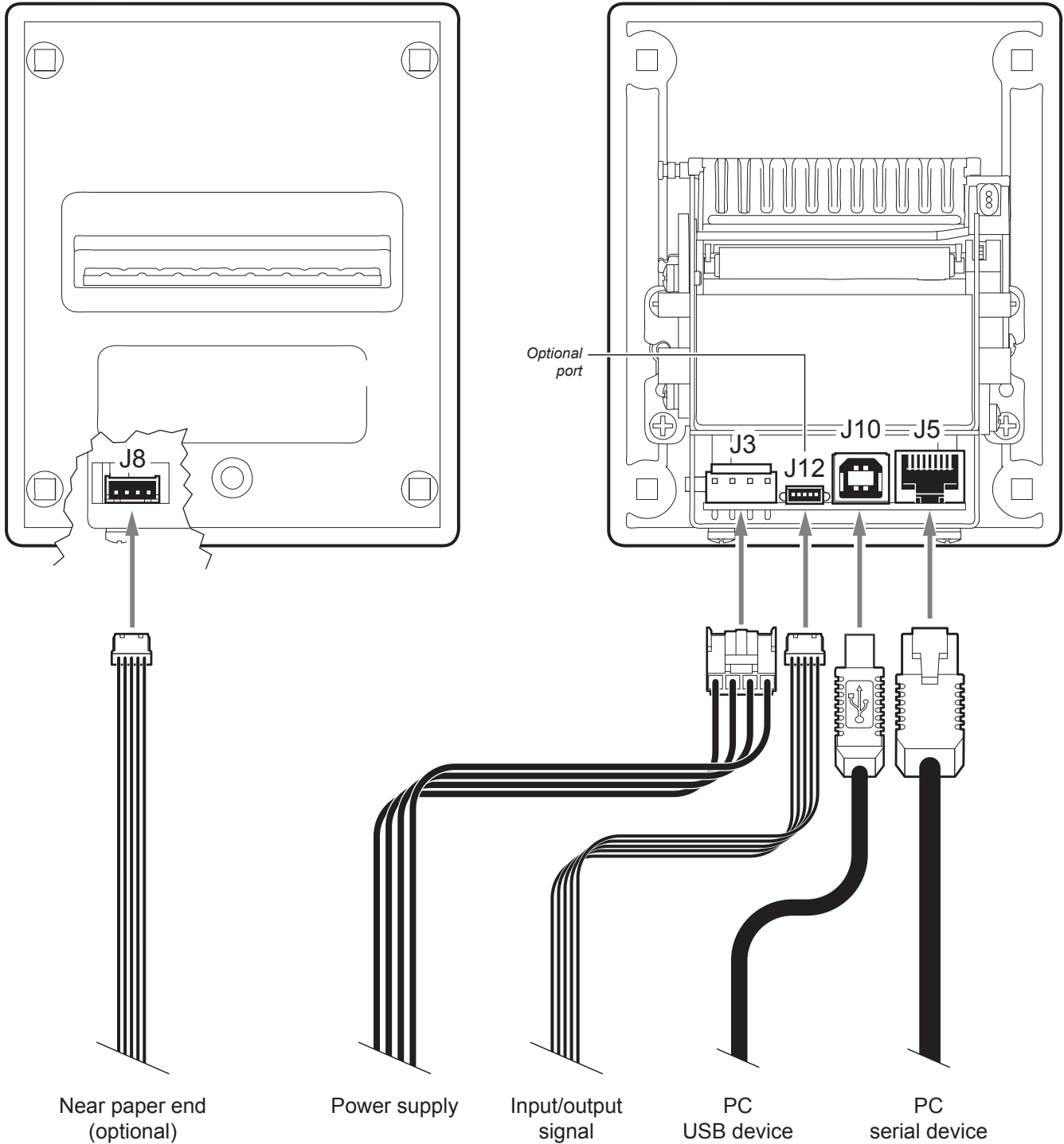

3.4 Pinout

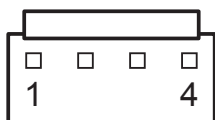

POWER SUPPLY

Male 4 ways JST connector (90°) [JST00621 B4PS-VH(LF)(SN)]

J3	1	OUT
	2	+Vin
	3	GND
	4	IN

ATTENTION:
Respect power supply polarity.

NOTE: Power supply cable
The following figure shows the connector pinout of the power supply cable for the device:

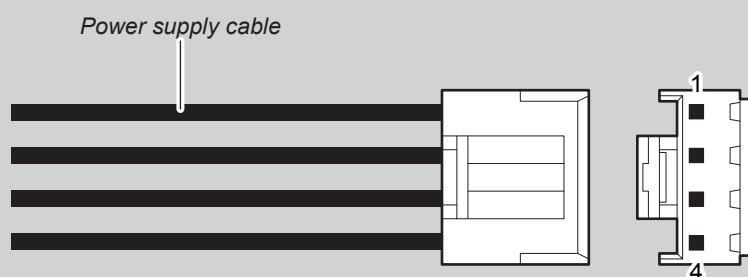

Female JST connector series VHR-4N or VHR-4M

PIN	Cable color	Signal
1	White	OUT
2	Red	+Vin
3	Black	GND
4	Orange	IN

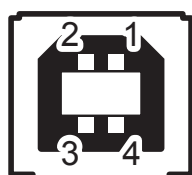

USB INTERFACE

Female USB type B connector

J10	1	USB0-VBUS (in)
	2	USB0_D- (in/out)
	3	USB0_D+ (in/out)
	4	GND
	SH1	SHIELD
	SH2	SHIELD

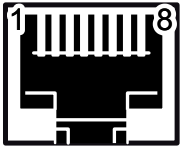

RS232/TTL SERIAL INTERFACE

Female RJ45 connector

J5	1	+3.3V	
	2	GND	
	3	TX	During transmission, takes the values "0" and "1" depending on data
	4	RX	During reception, takes the values "0" and "1" depending on data
	5	RTS	When "0", printer is ready to receive data
	6	+Vi	
	7	EN-3V3	
	8	IO	

NOTES:

Device > PC connection

The following picture shows an example of connection between the device and a personal computer using a 8 pin RJ45 serial connector:

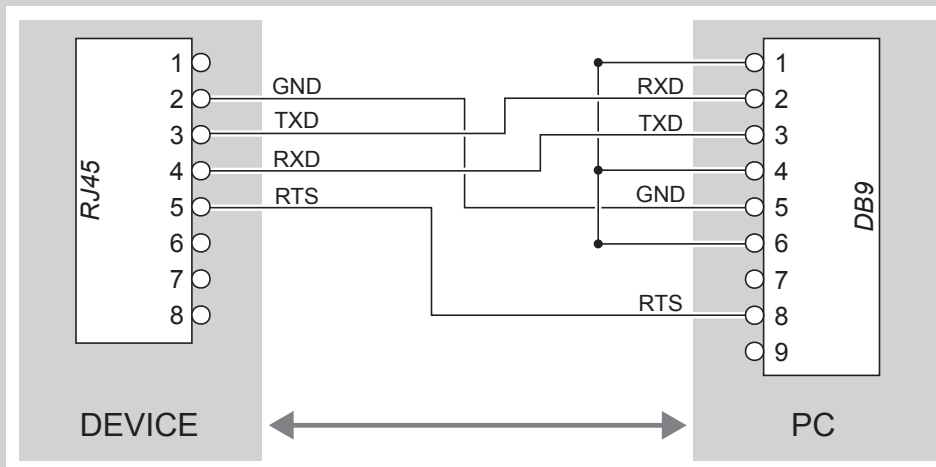

When use a serial cable, we recommend the installation of a ferrite core on the power supply cable.

Given the presence of the RS232 standard, logic value "0" corresponds to a voltage level of between +3Vdc and +15Vdc and logic value "1" corresponds to a voltage level of between -3Vdc and -15Vdc.



NEAR PAPER END

Male 4 ways JST connector (S4B-PH-SM4-TB)

J8	1	+3.3V
	2	NPE (in)
	3	GND
	4	VLED-SENS

NOTE: Cable for near paper end sensor.

The following figure shows the connector pinout of the near paper end sensor cable for the device:

Cable for near paper end sensor

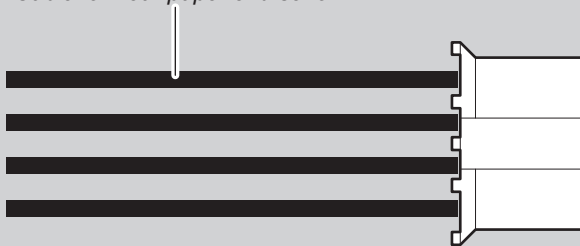

Female JST connector series PHR-4

PIN	Cable color	Signal
1	Red	+3.3V
2	Blue	NPE
3	Black	GND
4	Yellow	VLED-SENS



AUX INTERFACE (OPTIONAL)

Molex male connector 53261-0571 series (90°)

J12	1	+Vin
	2	GND
	3	AUX-IN1
	4	AUX-IN2
	5	AUX-OUT1

NOTE: AUX Cable.

The following figure shows the connector pinout of the AUX cable for the device:

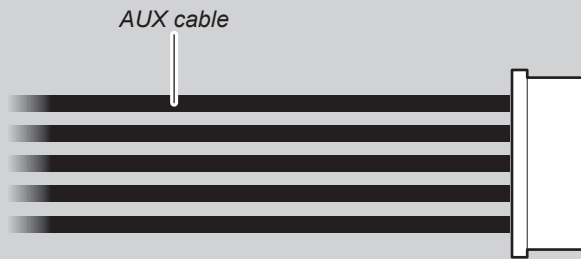

Female MOLEX connector series 51021-0500

PIN	Cable color	Signal
1	Red	+Vin
2	Black	GND
3	Yellow	AUX-IN1
4	Orange	AUX-IN2
5	Blue	AUX-OUT1

3.5 Serial port setting

Appropriately configure the type of serial communication by connecting the pads according to one of the two schemes shown in the figure (use a soldering iron). The device leaves the factory with the serial RS232 configuration.

WARNING: Paying attention to not heat excessively the closer components, to avoid to damage them.

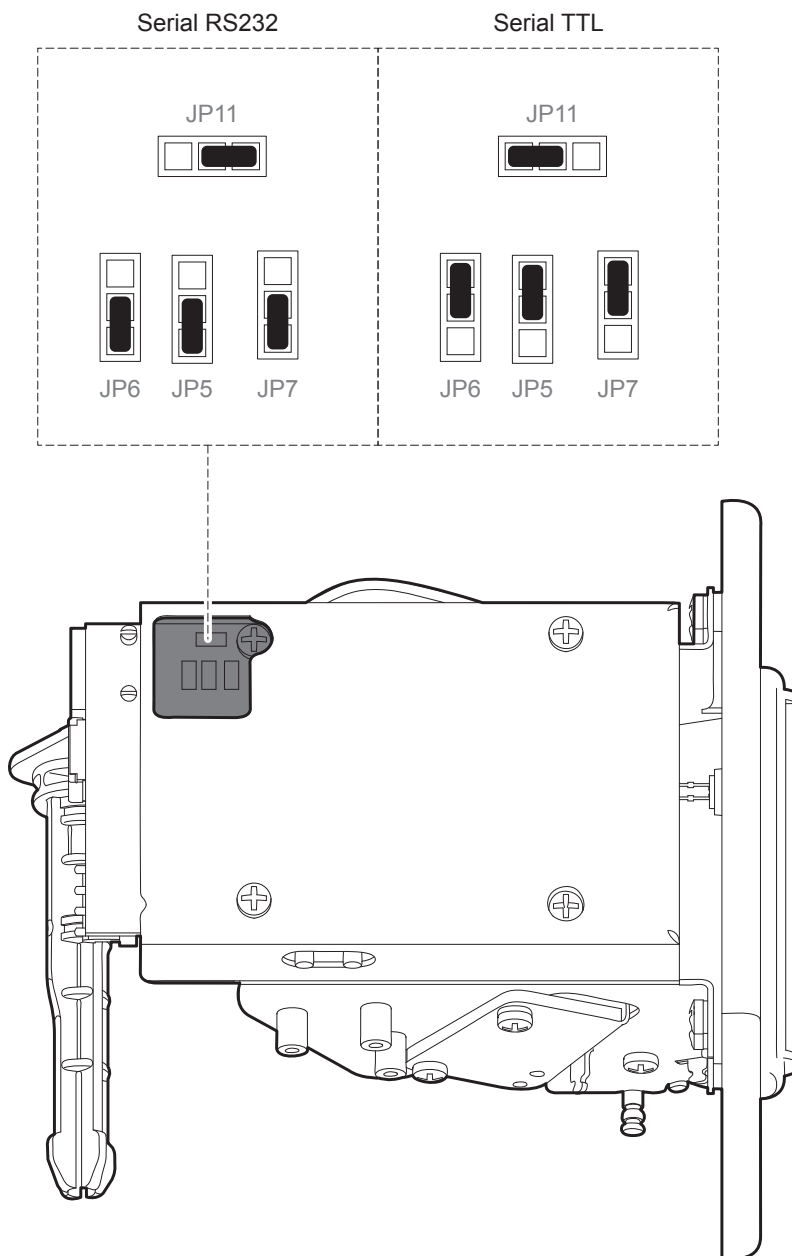

In the serial protocol, the signals which distinguish the communication are TD, RD, and RTS if the RTS/CTS protocol has been selected while, if the XON/XOFF protocol has been selected, the signals are TD and RD.

Transmission format



Notes:

- (1) Bit 7 is present if only in the printer set-up is enabled 8 bit/char as data length.
- (2) Parity Bit is preset if only in the printer set-up the parity is enabled.

RTS/CTS Protocol

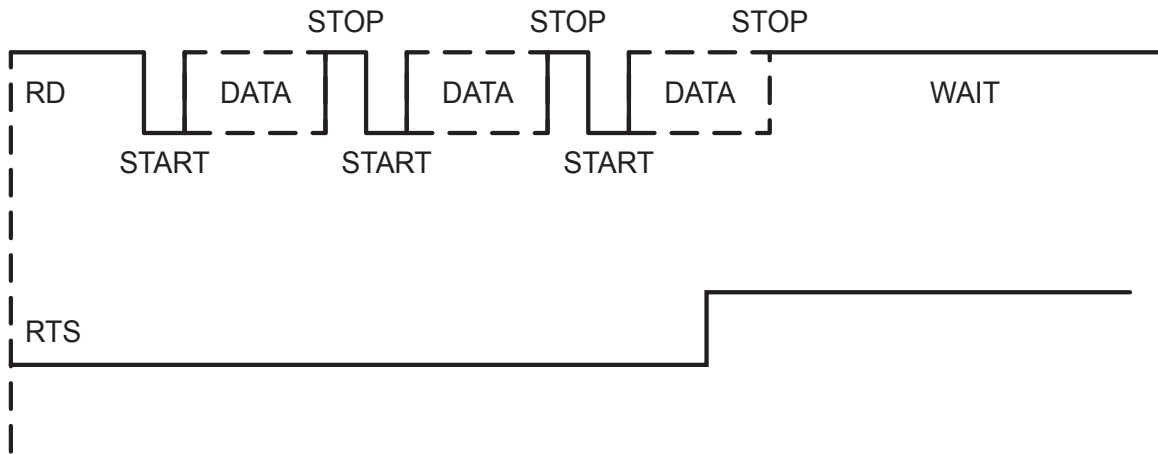

XON/XOFF protocol

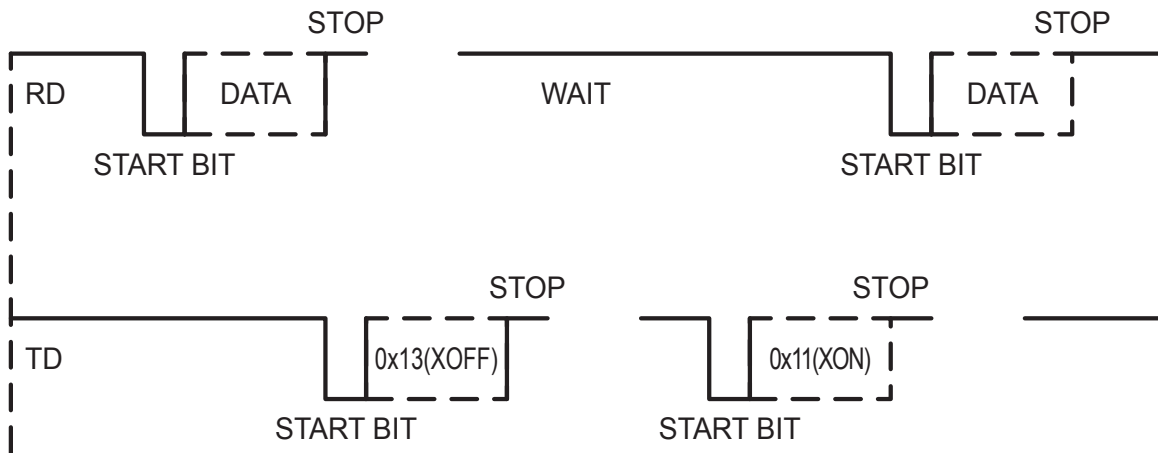

3.6 Driver and SDK

The drivers are available for the following operating system:

OPERATING SYSTEM	DESCRIPTION	INSTALLATION PROCEDURE
Windows	Driver per Windows XP	From the START menu, press Run and type-in the path where the SW was saved on your PC, then click OK. Follow the instructions that appear on the screen to install the driver.
	Driver per Windows VISTA (32/64bit)	
	Driver per Windows 7 (32/64bit)	
	Driver per Windows 8 (32/64bit)	
Linux		Follow the instruction get back on the README.TXT file. You can find it in the software package downloaded in advance.
Android	Library for CustomAndroidAPI	Extract the zipped folder to the destination path desired. Follow the instructions present in the software package that you downloaded on how to install and use the library.
iOS	Library for CustomiOSApi	Extract the zipped folder to the destination path desired. Follow the instructions present in the software package that you downloaded on how to install and use the library.

NOTA:

All drivers can be found in the DOWNLOAD section of the web site www.custom.biz.

4 OPERATION

4.1 Switch the device ON

1

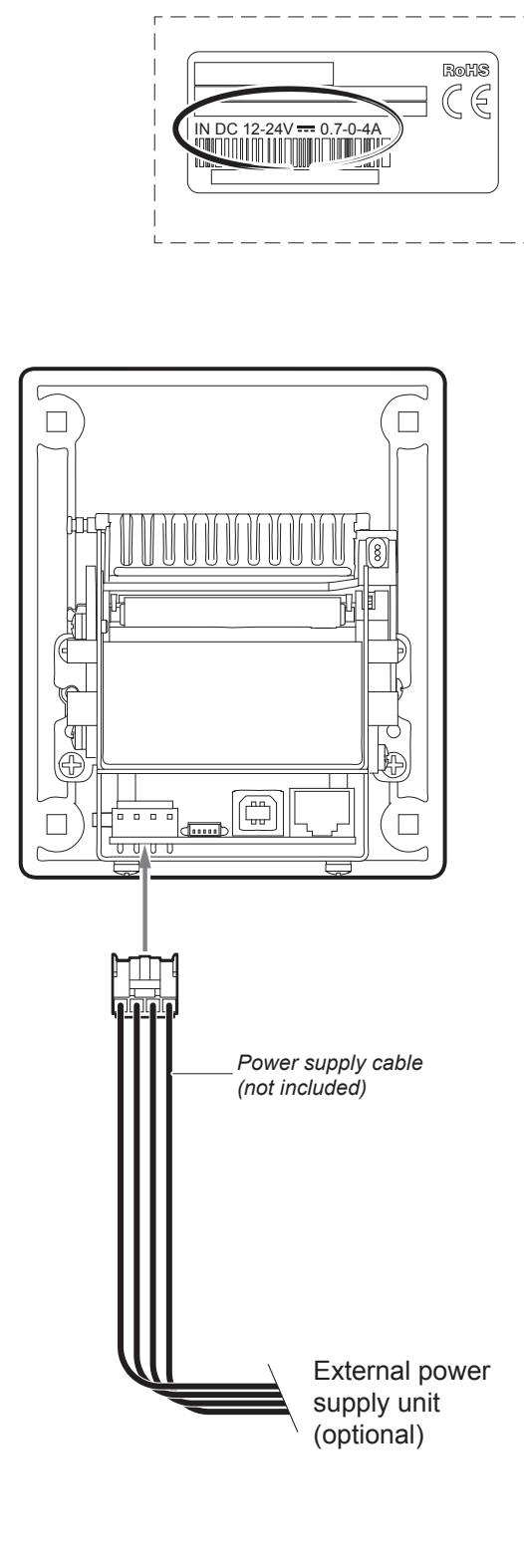

The diagram shows a power supply label with the text "IN DC 12-24V 0.7-0.4A" circled. Below the label is a detailed view of the device's internal components, including a power supply connector. A power supply cable is shown connected to the device. Labels indicate "Power supply cable (not included)" and "External power supply unit (optional)".

Connect the power supply cable to the device.
Use the type of electrical power supply indicated on the label.

2

Standard model

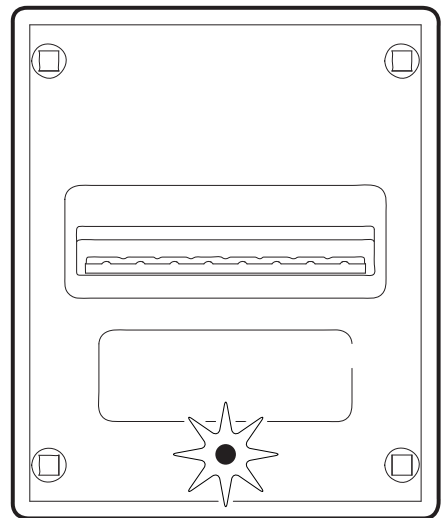

The diagram shows the front view of the standard model printer bezel, which is a rectangular frame with a paper slot and a status LED indicator.

Model with illuminated paper bezel

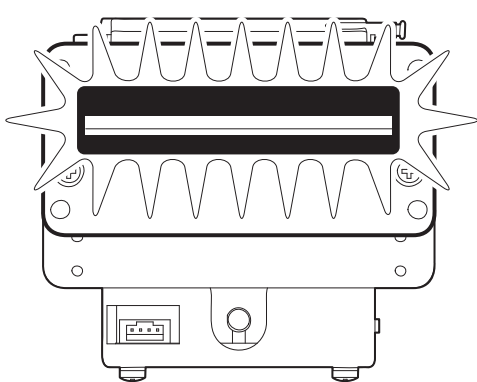

The diagram shows the front view of the model with illuminated paper bezel, which features a glowing paper slot and a status LED indicator.

The status LED lights green (standard model), the printer bezel lights blue (model with illuminated paper bezel). The device is ready.

4.2 Loading the paper roll

To change the paper proceed as follows. At every change of paper, check inside the printer to locate and remove any scraps of paper.

1

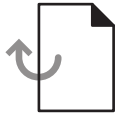

**SEE
PREVIOUS
PARAGRAPHS**

Adjust the paper roll holder following the instructions provided in the paragraph "Paper roll holder assembly".

2

Rib on the seeger

Rib on the seeger

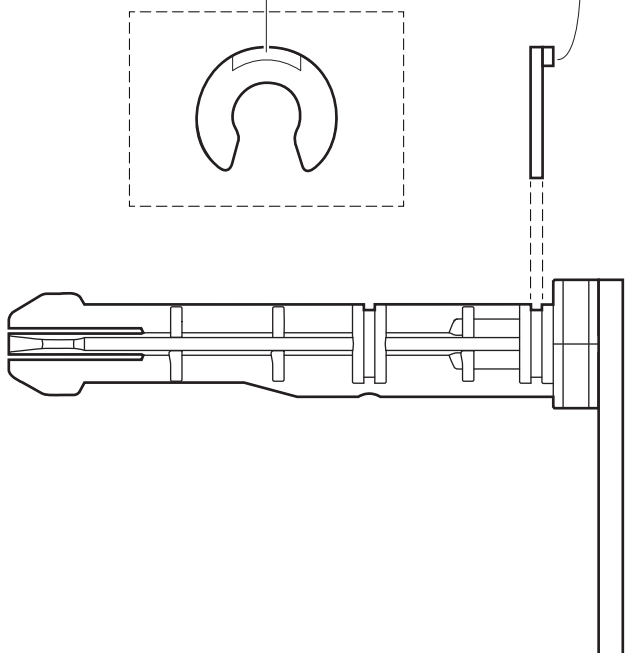

Insert on the pin the seeger included, pay attention to the orientation of the rib.

3

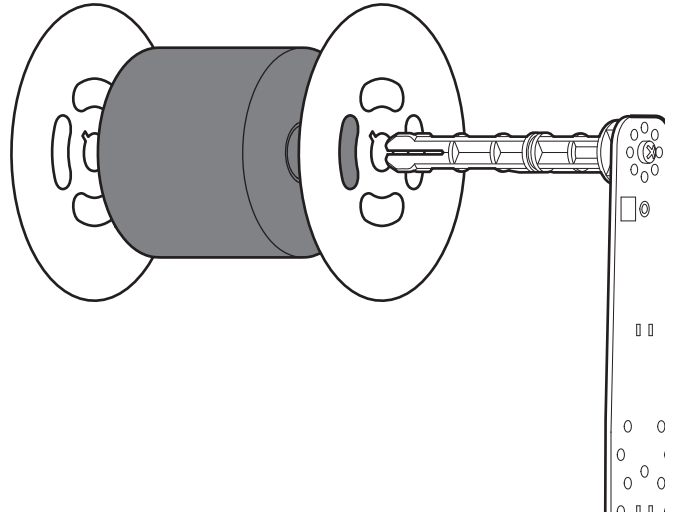

Insert on the pin, the disk of containment, the paper roll and the disk of containment.

4

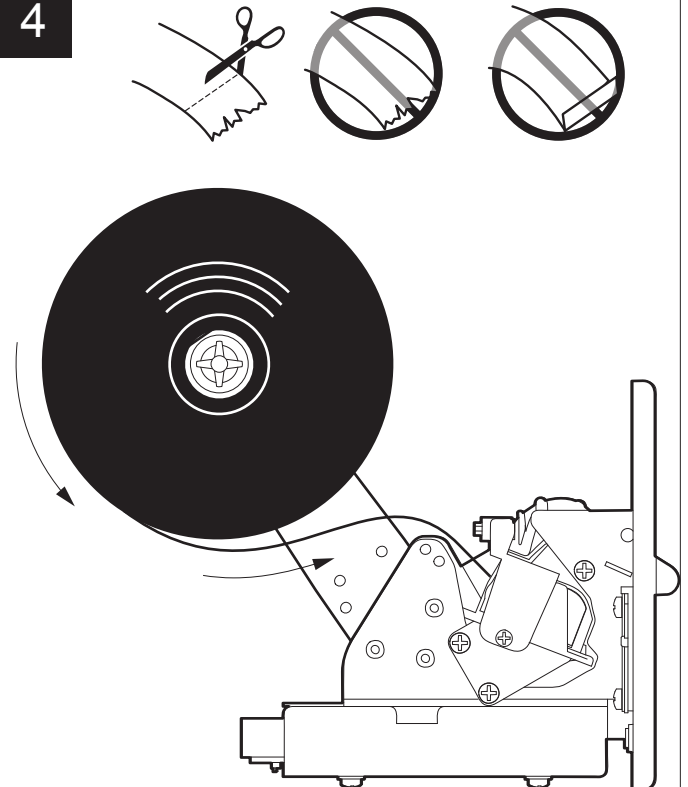

Insert the paper into the the input mouth so that it unrolls correctly, as shown in figure.

5

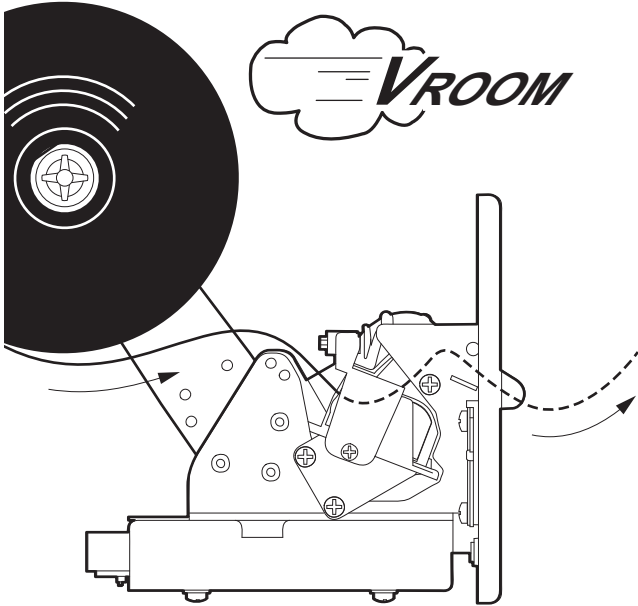

Wait until the paper is automatically loaded.

4.3 Issuing ticket

1

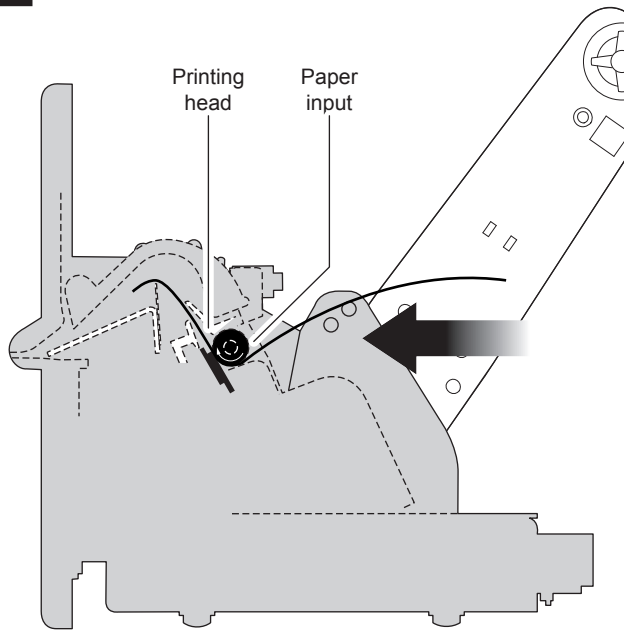

The device starts the ticket printing.

2

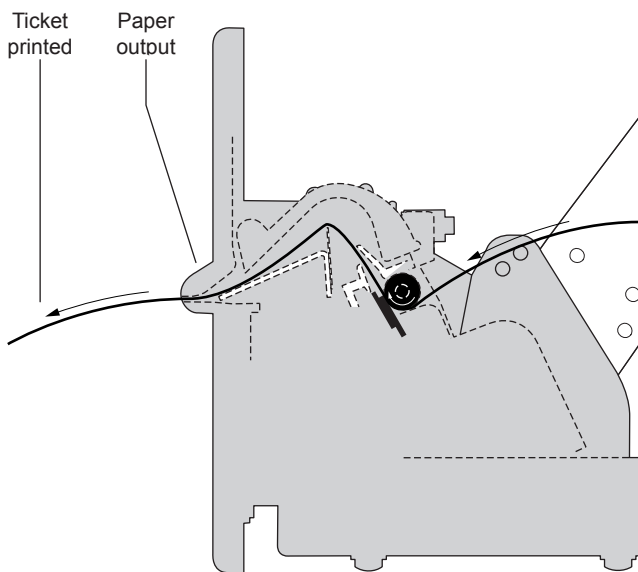

During printing, the ticket is presented in the paper mouth

3

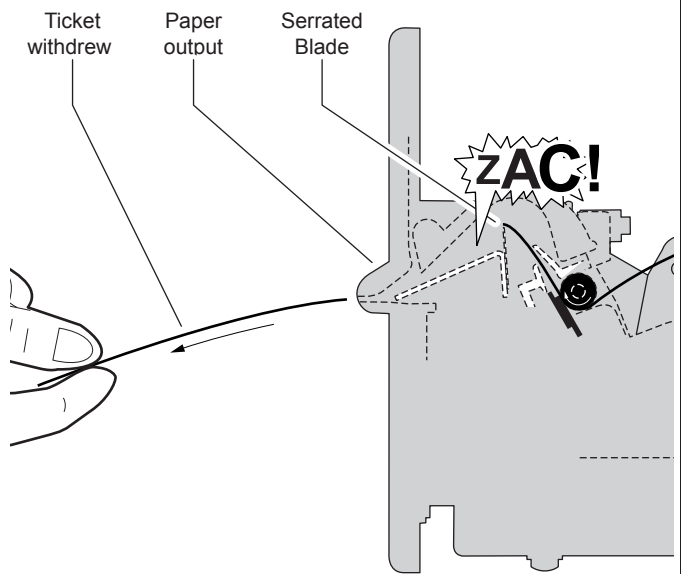

The user picks up the ticket by pulling it slightly towards you. The ticket is cut from the serrated blade.

5 CONFIGURATION

5.1 Configuration mode

To enter the configuration mode and print a SETUP report with the operating parameters of the device, proceed as follows.

1

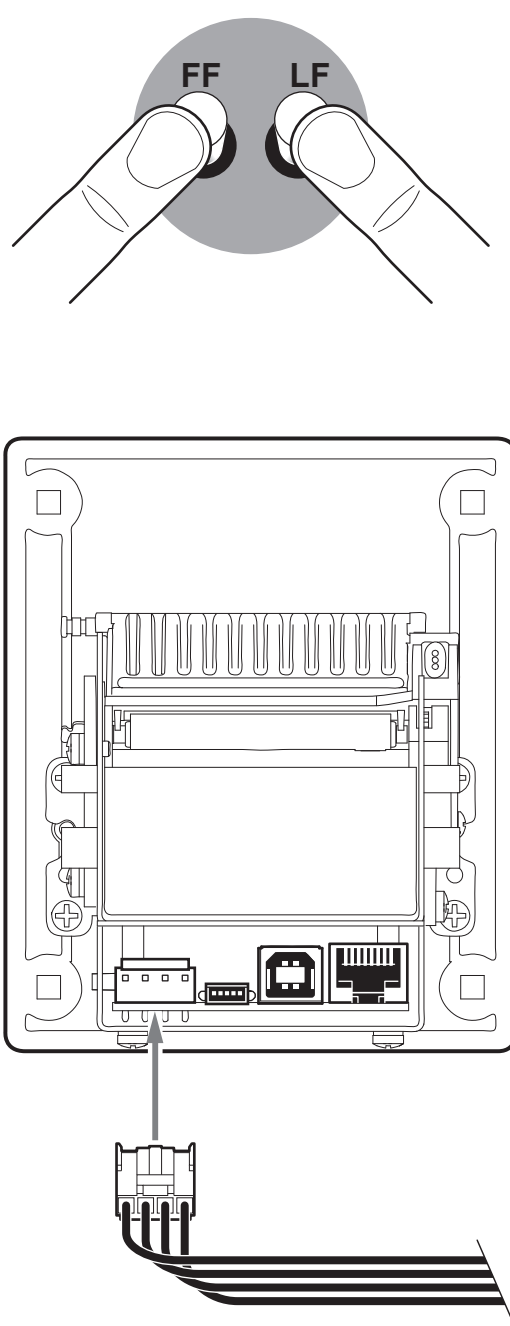

While pressing the LF LINE FEED key and the FF FORM FEED key, switch on the printer by inserting the power supply cable.

2

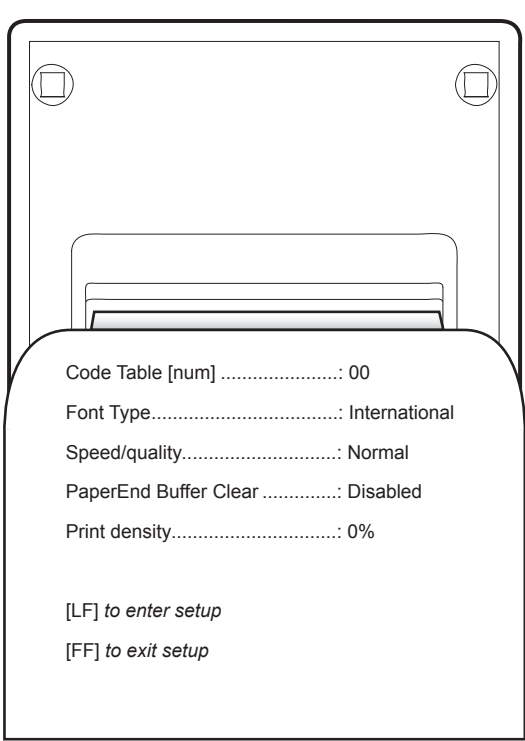

```
Code Table [num] .....: 00
Font Type.....: International
Speed/quality.....: Normal
PaperEnd Buffer Clear .....: Disabled
Print density.....: 0%

[LF] to enter setup
[FF] to exit setup
```

The printer prints the report with parameters for printer settings

3

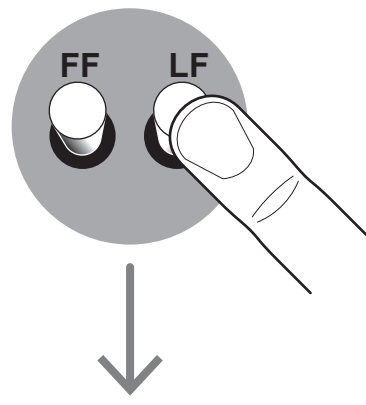

Enter printer setup

Press the LF LINE FEED key to enter the configuration mode

5.2 Setup report

The following figure shows the setup report of the device. The shown values for parameters are sample values; for the list and the description of device parameters see the following paragraphs.

*PRINTER NAME and
FIRMWARE MODULES
RELEASE*

```
TG02H printer
SCODE <code>          - rel 1.00
FCODE <code>          - rel 1.00
```

*DEVICE
STATUS*

```
PRINTER SETTINGS

PRINTER TYPE .....TG02H
PRINTING HEAD TYPE .....KF2002
INTERFACE .....RS232
PROGRAM MEMORY TEST.....OK
DYNAMIC RAM TEST.....OK
EEPROM TEST.....OK
HEAD VOLTAGE          [V] = 04.84
HEAD TEMPERATURE     [°C] = 25
POWER ON COUNTER     = 4
PAPER PRINTED        [cm] = 40
```

*PRINTER
PARAMETERS*

```
RS232 Baud Rate .....: 9600 bps
RS232 Data Length.....: 8 bits/chr
RS232 Parity .....: None
RS232 Handshaking .....: Xon/Xoff
Busy Condition .....: RxFull
USB Address Number .....: 0
USB Virtual COM.....: Disabled
Print Mode .....: Reverse
Autofeed CR.....: Enabled
Chars / inch .....: 12 cpi def
Code Table [num] .....: 00
Font Type.....: International
Speed / Quality.....: Normal
PaperEnd Buffer Clear .....: Disabled
Print Density.....: 0%
```

KEYS FUNCTIONS

```
[ LF ] to enter setup
[ FF ] to exit setup
```

5.3 Printer status

The printer operating status is indicated in the configuration print-out in which, next to the name of the components displayed, the following information is given:

PRINTER TYPE	<i>device model</i>
PRINTING HEAD TYPE	<i>print head model</i>
INTERFACE	<i>interface present</i>
PROGRAM MEMORY TEST	<i>OK appears if functioning and NOT OK if faulty</i>
DYNAMIC RAM TEST	<i>OK appears if functioning and NOT OK if faulty</i>
EEPROM TEST	<i>OK appears if functioning and NOT OK if faulty</i>
HEAD VOLTAGE	<i>voltage of the head</i>
HEAD TEMPERATURE	<i>temperature of the head</i>
POWER ON COUNTER	<i>number of power-ups made</i>
PAPER PRINTED	<i>centimetres of paper printed</i>

5.4 Printer parameters

This printer allows the configuration of the parameters listed in the following table. The parameters marked with the symbol ^D are the default values. Settings remain active even after the printer has been turned off and they are stored in non-volatile memory.

RS232 BAUD RATE	<i>Communication speed of the serial interface:</i>										
	<table> <tbody> <tr> <td>115200</td> <td>9600^D</td> </tr> <tr> <td>57600</td> <td>4800</td> </tr> <tr> <td>38400</td> <td>2400</td> </tr> <tr> <td>19200</td> <td>1200</td> </tr> </tbody> </table>	115200	9600 ^D	57600	4800	38400	2400	19200	1200		
115200	9600 ^D										
57600	4800										
38400	2400										
19200	1200										
	NOTE: Parameter valid only with serial interface.										
RS232 DATA LENGTH	<i>Number of bit used for characters encoding:</i>										
	<table> <tbody> <tr> <td>7 bits/car</td> </tr> <tr> <td>8 bits/car^D</td> </tr> </tbody> </table>	7 bits/car	8 bits/car ^D								
7 bits/car											
8 bits/car ^D											
	NOTE: Parameter valid only with serial interface.										
RS232 PARITY	<i>Bit for the parity control of the serial interface:</i>										
	<table> <tbody> <tr> <td>None^D</td> <td>=</td> <td>parity bit omitted</td> </tr> <tr> <td>Even</td> <td>=</td> <td>even value for parity bit</td> </tr> <tr> <td>Odd</td> <td>=</td> <td>odd value for parity bit</td> </tr> </tbody> </table>	None ^D	=	parity bit omitted	Even	=	even value for parity bit	Odd	=	odd value for parity bit	
None ^D	=	parity bit omitted									
Even	=	even value for parity bit									
Odd	=	odd value for parity bit									
	NOTE: Parameter valid only with serial interface.										
RS232 HANDSHAKING	<i>Handshaking:</i>										
	<table> <tbody> <tr> <td>XON/XOFF^D</td> <td>=</td> <td>software handshaking</td> </tr> <tr> <td>Hardware</td> <td>=</td> <td>hardware handshaking (CTS/RTS)</td> </tr> </tbody> </table>	XON/XOFF ^D	=	software handshaking	Hardware	=	hardware handshaking (CTS/RTS)				
XON/XOFF ^D	=	software handshaking									
Hardware	=	hardware handshaking (CTS/RTS)									
	<p>NOTES: Parameter valid only with serial interface.</p> <p>When the receive buffer is full, if handshaking is set to XON/XOFF, the printer sends the XOFF (0x13) on the serial port. When the receive buffer has cleared once again, if handshaking is set to XON/XOFF, the printer sends the XON (0x11) on the serial port.</p>										
BUSY CONDITION	<i>Activation mode for Busy signal:</i>										
	<table> <tbody> <tr> <td>OffLine/ RXFull</td> <td>=</td> <td>Busy signal is activated when the printer is both in OffLine status and the buffer is full</td> </tr> <tr> <td>RXFull^D</td> <td>=</td> <td>Busy signal is activated when the buffer is full</td> </tr> </tbody> </table>	OffLine/ RXFull	=	Busy signal is activated when the printer is both in OffLine status and the buffer is full	RXFull ^D	=	Busy signal is activated when the buffer is full				
OffLine/ RXFull	=	Busy signal is activated when the printer is both in OffLine status and the buffer is full									
RXFull ^D	=	Busy signal is activated when the buffer is full									
	NOTE: Parameter valid only with serial interface.										
USB ADDRESS NUMBER	<i>Numerical address code for the univocal identification of the USB device (in case of more than a USB device connected with the same PC):</i>										
	<table> <tbody> <tr> <td>0^D</td> <td>2</td> <td>4</td> <td>6</td> <td>8</td> </tr> <tr> <td>1</td> <td>3</td> <td>5</td> <td>7</td> <td>9</td> </tr> </tbody> </table>	0 ^D	2	4	6	8	1	3	5	7	9
0 ^D	2	4	6	8							
1	3	5	7	9							

USB VIRTUAL COM

Setting the USB port as a virtual serial port:

Disabled^D = Virtual COM disabled

Enabled = Virtual COM enabled

NOTA: To use this configuration it is necessary to install an additional driver.

PRINT MODE

Printing mode:

Normal = enables printing in normal writing way

Reverse^D = enables printing rotated 180 degrees

AUTOFEED CR

Setting of the Carriage Return character:

Disabled = Carriage Return disabled

Enabled^D = Carriage Return enabled

CHARS / INCH

Font selection:

12 cpi def^D

12/16 cpi

16/22 cpi

NOTES:
CPI = Characters Per Inch

CODE TABLE [num]

Identifier number of the character code table to use.

The numeric value of the identifier is made up with the following two parameters for the setting of two digits for the tens and the units:

Setting the digit for tens:

CODE TABLE [num x 10]

<i>0^D</i>	<i>2</i>	<i>4</i>
<i>1</i>	<i>3</i>	<i>5</i>

Setting the digit for units:

CODE TABLE [num x 1]

<i>0^D</i>	<i>2</i>	<i>4</i>	<i>6</i>	<i>8</i>
<i>1</i>	<i>3</i>	<i>5</i>	<i>7</i>	<i>9</i>

NOTE:
See the paragraph 7.4 to learn about the character tables corresponding to the identification numbers set with this parameter.

The character tables set with this parameter are the same set with the command 0x1B 0x74 (refer to the Commands Manual of the device).

FONT TYPE

Setting of the font type:

International^D = Enables the use of the 256-characters font tables

Chinese GB18030 = Enables the use of the chinese extended font GB18030-2000

Korean PC949 = Enables the use of the korean font PC949

NOTE: When the "INTERNATIONAL" font type is enabled, must be selected the desired character code table (parameter "CODE TABLE"). When the chinese or korean font is enabled, the selection of the character code table is suspended (par. "CODE TABLE").

SPEED / QUALITY

Setting of printing speed and printing quality:

Normal ^D

High Quality

**PAPEREND BUFFER
CLEAR**

Cleaning mode of the data in receive buffer, if the printing is stopped due to lack of paper:

Disabled ^D = The data remain in the receive buffer. When the paper runs out, the printer keeps the remaining data in the receive buffer and prints the remaining portion of the ticket after that the new paper is loaded.

Enabled = When the paper runs out, all data in the receive buffer are deleted.

PRINT DENSITY

Adjusting the printing density:

-50% -12% +25%

-37% 0 ^D +37%

-25% +12% +50%

5.5 Hexadecimal dump

This function is used for the diagnosis of the characters received from the communications port. Characters are printed as hexadecimal code and the corresponding ASCII code (see below). Each line is preceded by a counter in hexadecimal that indicates the number of bytes received.

During the startup, if you hold down both the LF LINE FEED key and the FF FORM FEED key, the printer enters the self-test routine and print the setup report. The printer remains in standby until a key is pressed or characters are received through the communication port (Hexadecimal Dump mode). For each character sent, the ticket shows the hexadecimal value and the ASCII codes (if the characters are underlined, the receive buffer is full). Shown below is an example of a Hexadecimal Dump:

HEXADECIMAL DUMP						
31	32	33	34	35	...	12345 ...
39	30	31	32	33	...	90123 ...
37	38	39	75	69	...	789ui ...
68	6B	6A	73	64	...	hkjsd ...
73	64	66	6B	6A	...	sdfkj ...
66	73	64	66	6B	...	fsdfk ...
65	69	6F	79	75	...	eioyu ...
6F	72	69	75	77	...	oriuw ...
6F	75	77	65	72	...	ouwer ...
77	65	72	69	6F	...	werio ...
72	69	6F	75	77	...	riouw ...
6B	6C	73	64	66	...	kl sdf ...
64	66	6B	73	64	...	dfksd ...
73	64	66	6B	6A	...	sdfkj ...
66	6B	F2	6A	73	...	fk>j ...
6A	6B	6C	68			jklh

6 MAINTENANCE

6.1 Printer paper jam

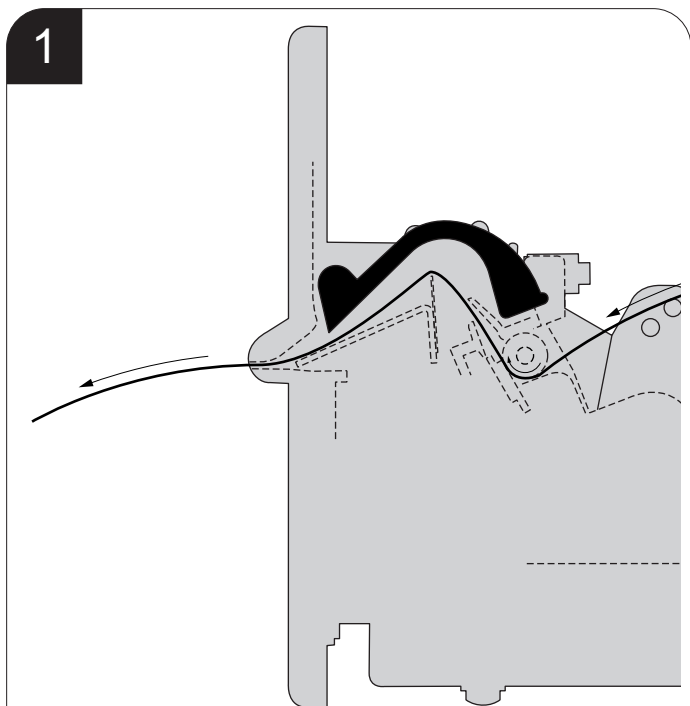

In the 'normal' printing conditions the inspection door is down.

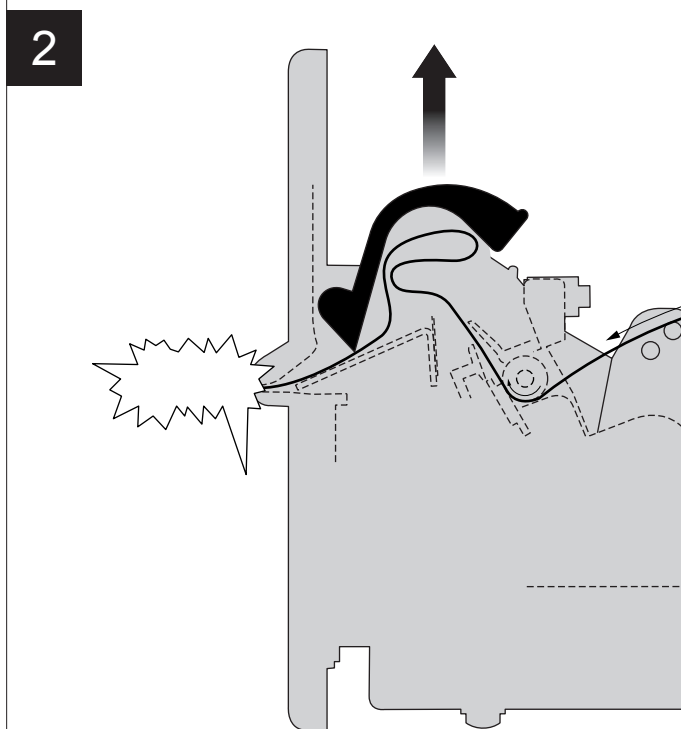

In case of paper jam the inspection door is lifted from this one, generating the condition of 'Jam'.

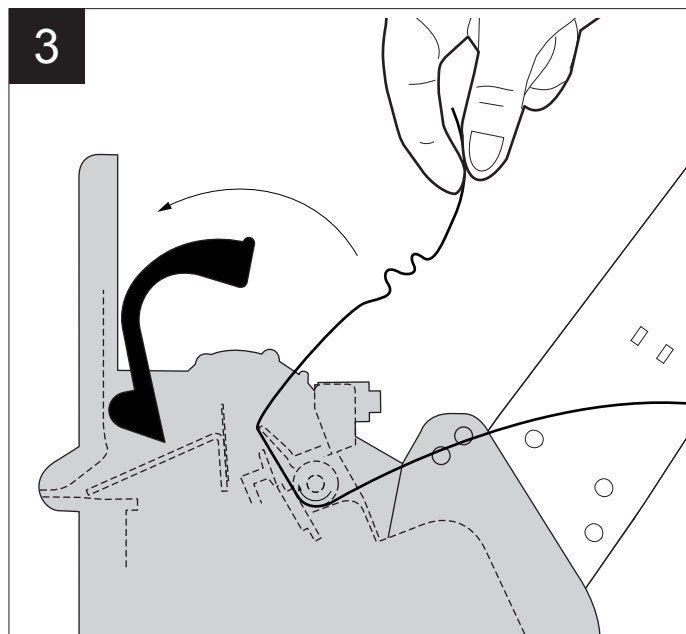

Lift the inspection door and take out the damaged paper

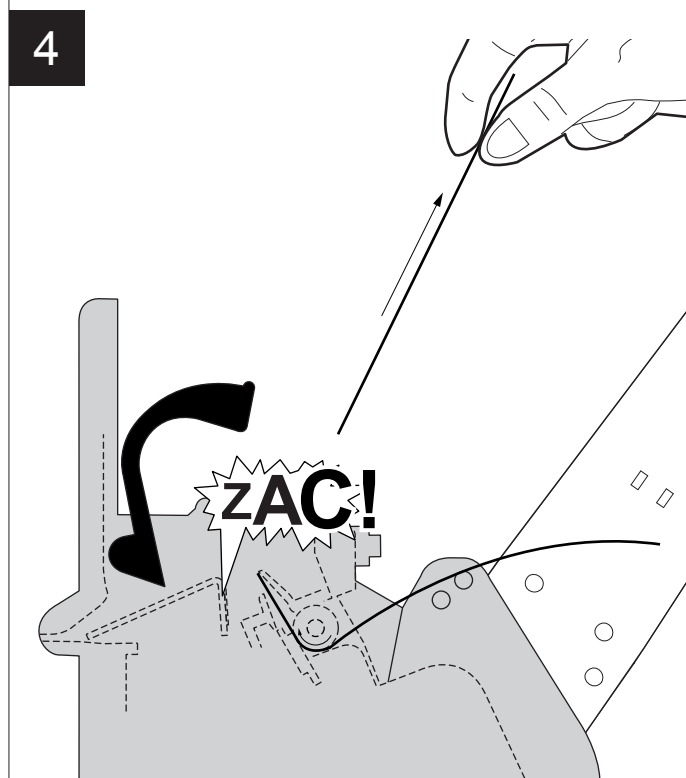

Pull the damaged paper to tear off the exceeding one.

6.2 Planning of cleaning operations

The regular cleaning of the device keeps the print quality and extends its life. The following table shows the recommended planning for the cleaning operations.

EVERY PAPER CHANGE	
Rollers	Use isopropyl alcohol
EVERY 5 PAPER CHANGES	
Paper path	Use compressed air or tweezers
Sensors	Use compressed air
EVERY 6 MONTHS OR AS NEEDED	
Printer case	Use compressed air or a soft cloth

For specific procedures, see the following pages.

NOTE:

If you use the device in dusty environments, you must reduce the intervals between the cleaning operations.

6.3 Cleaning

For periodic cleaning of the device, see the instructions below

Sensors

1

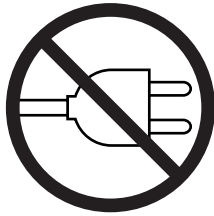



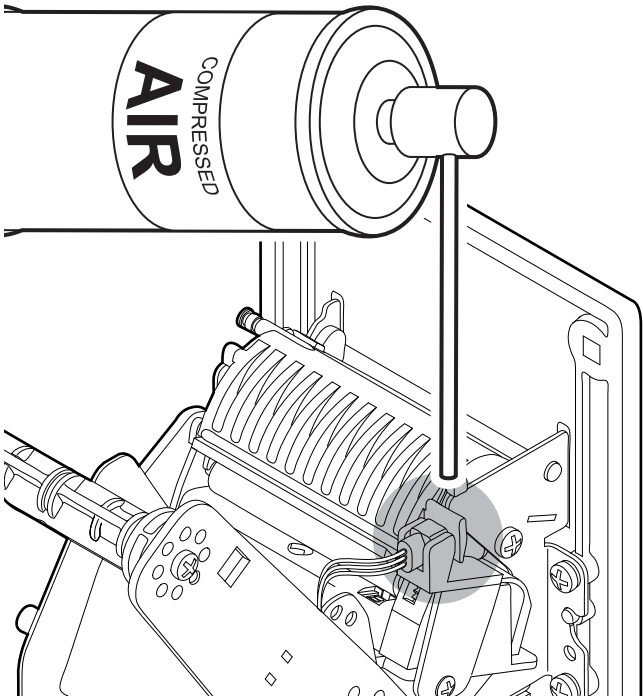

Disconnect the power supply cable

2



Clean the printer sensor by using compressed air

ATTENTION:
Do not use alcohol, solvents, or hard brushes.
Do not let water or other liquids get inside the machine.



Case

1

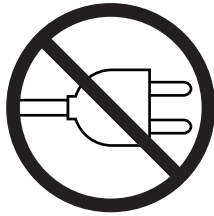



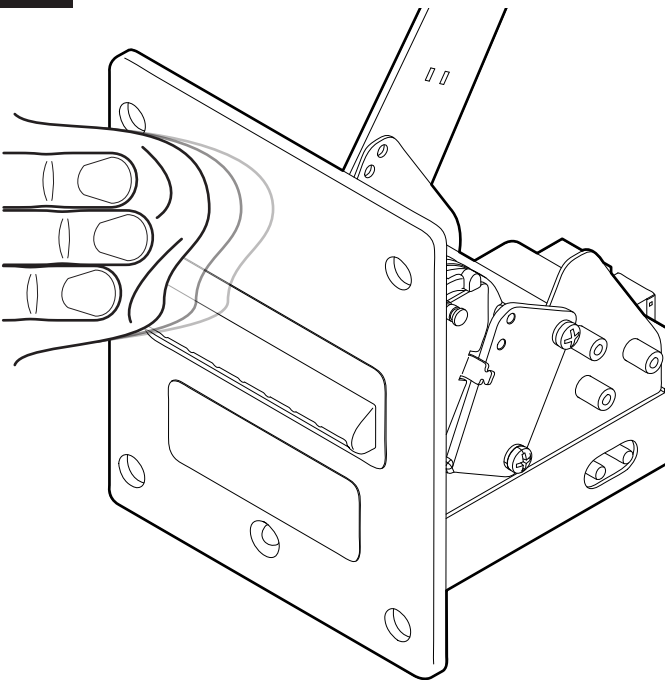

Disconnect the power supply cable

2



To clean the machine, use compressed air or a soft cloth.

ATTENTION:
Do not use alcohol, solvents, or hard brushes.
Do not let water or other liquids get inside the machine.



Paper path

1

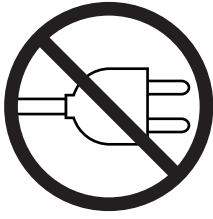

Disconnect the power supply cable

2

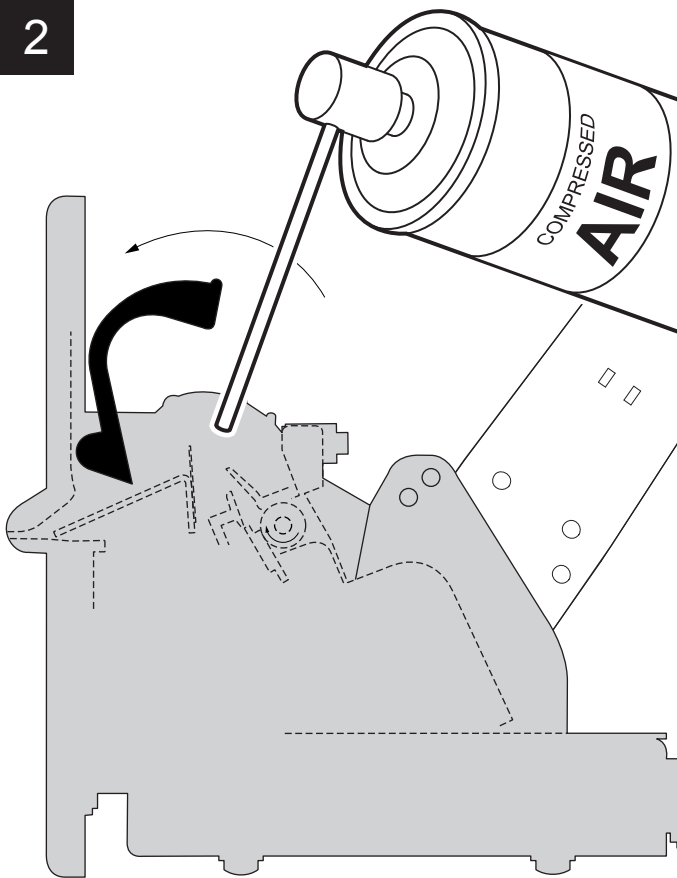

Open the inspection door and clean the area involved in the passage of paper by using compressed air.

ATTENTION:

Do not use alcohol, solvents, or hard brushes.
Do not let water or other liquids get inside the machine.



Printing roller

1

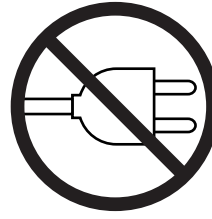

Disconnect the power supply cable

2

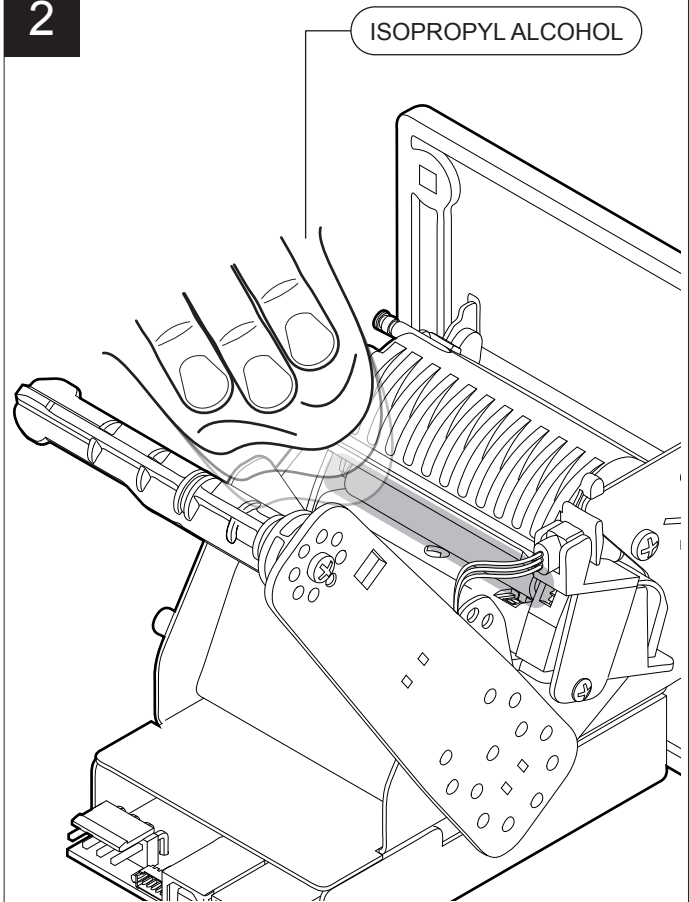

Clean the printing roll by using a non-abrasive cloth moistened with isopropyl.

ATTENTION:

Do not use solvents, or hard brushes.
Do not let water or other liquids get inside the machine.



6.4 Upgrade firmware

WARNING: During communication between PC and device for the firmware update it is strictly forbidden to disconnect the communication cable or to remove the power supply of the devices not to endanger the proper functioning of the machine.

NOTES:

The latest firmware of the device is available in the download area of the web site www.custom.biz

Install on the PC used for printer upgrading the UPG-CEPRN software available in the download area of the web site www.custom.biz.

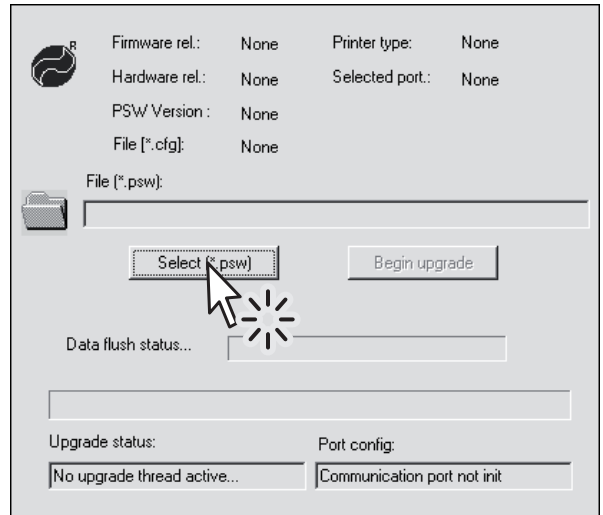

9. Select item USB and then select the USB device among those proposed (e.g. TG02H):

Update via USB interface

ATTENTION:

Only during the firmware update, the connection between PC and device must be direct, without the use of HUB device.

Only during the firmware update, do not connect or disconnect other USB devices.

NOTE: For communication via USB you must install on PC the printer driver available in the download area of the web site www.custom.biz.

Proceed as follows:

1. Write down the product code (14 digits) printed on the product label (see par.2.3).
2. Go to the web site www.custom.biz and download the appropriate firmware release from the DOWNLOAD area.
3. Print the SETUP report (see chapter 5).
4. Switch OFF the device.
5. Connect the device to the PC using a USB cable (see paragraph 3.3).
6. Switch ON the device.
7. Launch the software UPGCEPRN.
8. Select the update file .PSW location:

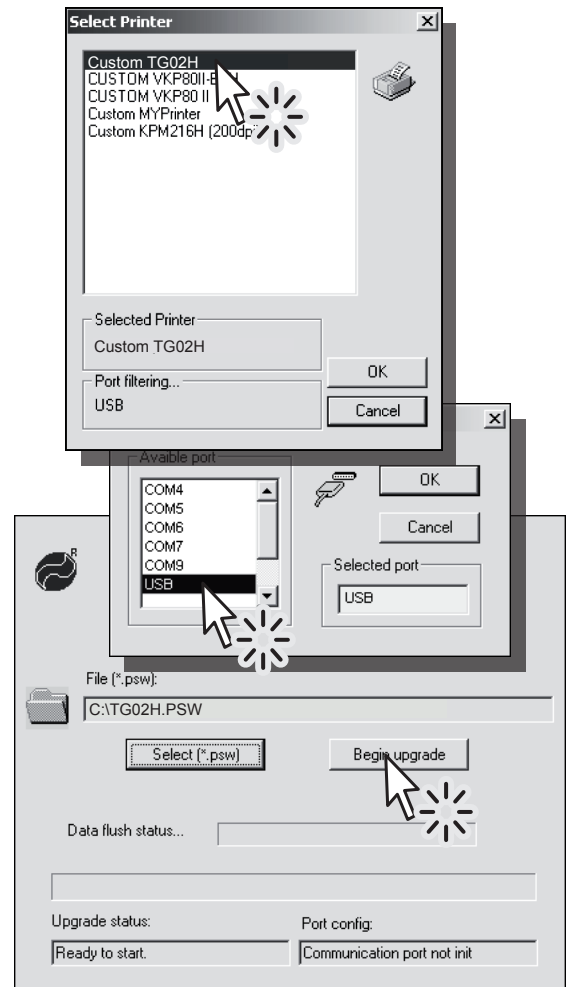

10. After a few minutes a message on the screen warns that the update is completed.

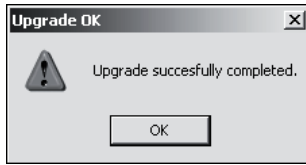

11. Print a new SETUP report to verify the new firmware release (see chapter 5).

7 SPECIFICATION

7.1 Hardware specifications

Operating temperature	
Sensors	Head temperature, paper presence, paper jam
Emulations	ESC/POS™
Printing driver	Windows XP, VISTA (32/64bit), Windows 7 (32/64bit), Windows 8 (32/64bit), Linux, Android iOS
INTERFACES	
USB port	12 Mbit/sec (USB 2.0 full speed)
RS232/TTL serial port	from 1200 to 115200 bps
AUX port	
MEMORIES	
Receive buffer	8 Kbytes
Flash memory	4 Mbytes (external)
Graphic memory	2 logos (384x682 dots)
PRINTER	
Resolution	203 dpi (8 dot/mm)
Printing method	Thermal, fixed head
Head life ⁽¹⁾	50 Km / 100M pulse
Printing width	48 mm
Printing mode	Normal, 180°

Printing format	12 cpi: Height/Width from 1 to 4, bold, reverse, underlined, italic 12/16, 16/22 cpi: Height/Width from 1 to 8, bold, reverse, underlined, italic
-----------------	--

Character fonts	54 character code tables (see par. 7.4) Extended chinese GB18030-2000 Korean PC949
-----------------	--

Printable barcode	UPCA, UPCE, EAN13, EAN8, CODE39, ITF, CODABAR, CODE93, CODE128, CODE32, QR CODE
-------------------	--

Printing speed ^{(1) (2)}	Normal = 80 mm/sec High Quality = 60 mm/sec
-----------------------------------	--

PAPER

Type of paper	Thermal rolls, heat-sensitive side on outside of roll
---------------	---

Paper width	57 mm ± 0,5 mm
-------------	----------------

Paper weight	from 55 g/m ² to 60 g/m ²
--------------	---

Paper thickness	from 63 µm to 65 µm
-----------------	---------------------

Recommended types of paper	KANZAN KF50 MITSUBISHI PG5075
----------------------------	----------------------------------

External roll diameter ⁽³⁾	max.70 or 90 mm
---------------------------------------	-----------------

External roll core diameter	12 mm (+ 1mm)
-----------------------------	---------------

Paper end	Not attached to roll core
-----------	---------------------------

Core type	Cardboard or plastic
-----------	----------------------

DEVICE ELECTRICAL SPECIFICATIONS

Power supply	12 ÷ 24 Vdc ±10% (optional external power supply)
--------------	---

Medium consumption ⁽²⁾	0.7 A (12 Vdc) 0.4 A (24 Vdc)
-----------------------------------	----------------------------------

Stand-by consumption	0.110 A (12 Vdc) 0.070 A (24 Vdc)
----------------------	--------------------------------------

ENVIRONMENTAL CONDITIONS

Operating temperature	from -20°C to +70°C
Relative humidity	from 10% Rh to 80% Rh
Storage temperature	from -20 °C to +70 °C
Storage relative humidity	from 10% Rh to 90% Rh

NOTES:

- (1) : Respecting the regular schedule of cleaning for the device components.
- (2) : Referred to a standard CUSTOM receipt (L=10cm, Density = 12,5% dots on).
- (3) : Depending on the mounting position of the paper roll holder (see par.7.3).

7.2 Character specifications in ESC/POS™ emulation

Character set		3	
Character density	12 cpi	16 cpi	22 cpi
Number of columns	24	32	42
Chars / sec	640	850	1140
Lines / sec	26	26	26
Characters (L x H mm)-Normal	2 x 3	1.5 x 3	1.125 x 3

7.3 Device dimensions

Standard model

Length	129 mm
Height	120 mm
Width	100 mm
Weight	330 g

NOTE:

Dimensions referred to devices without paper roll and without paper roll holder.
All the dimensions shown in following figures are in millimetres.

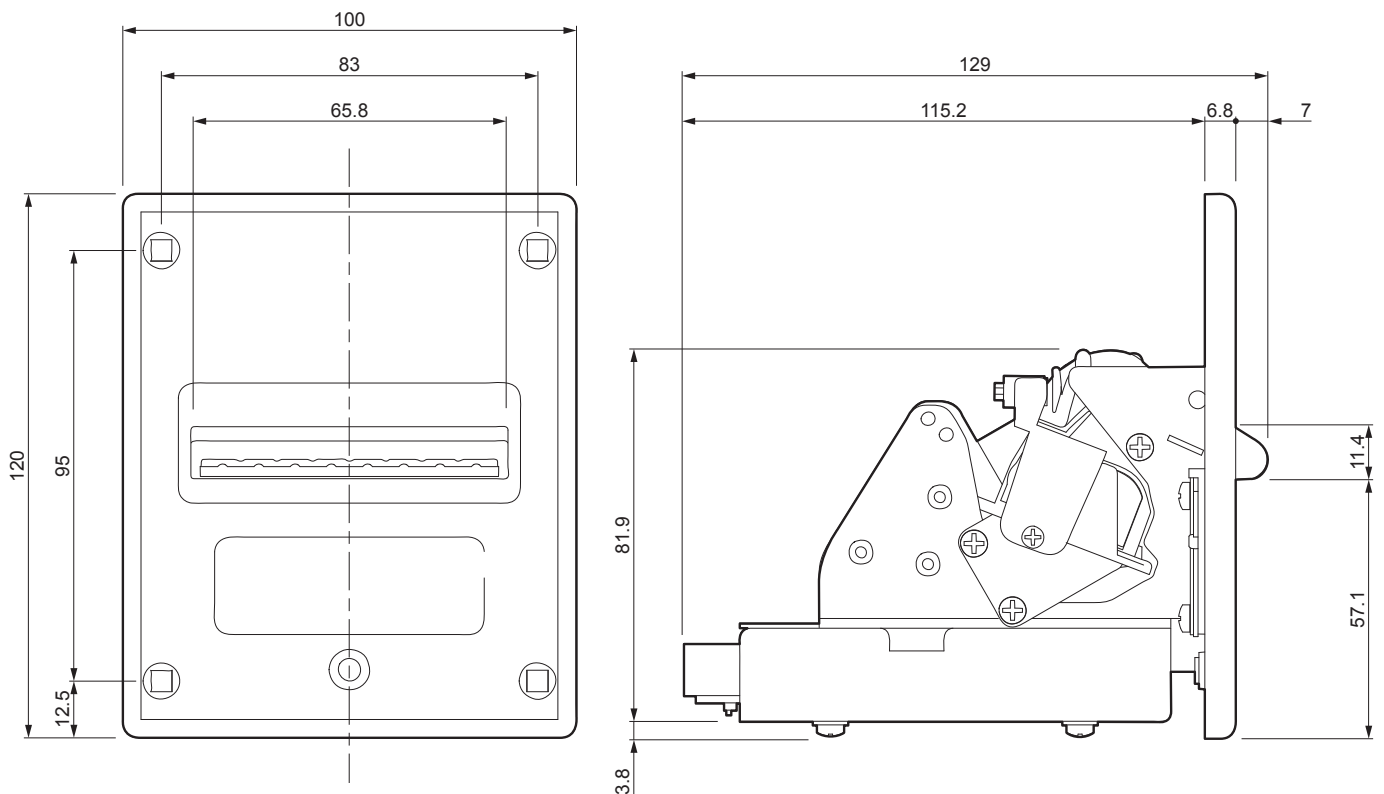

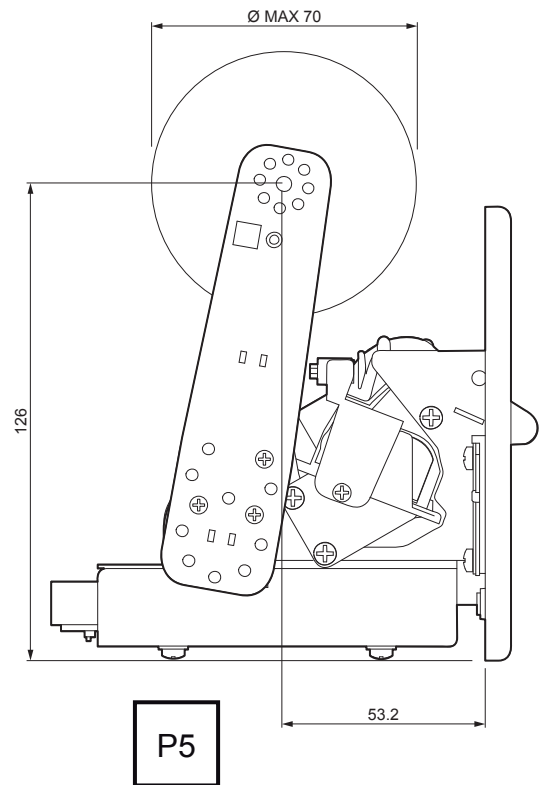
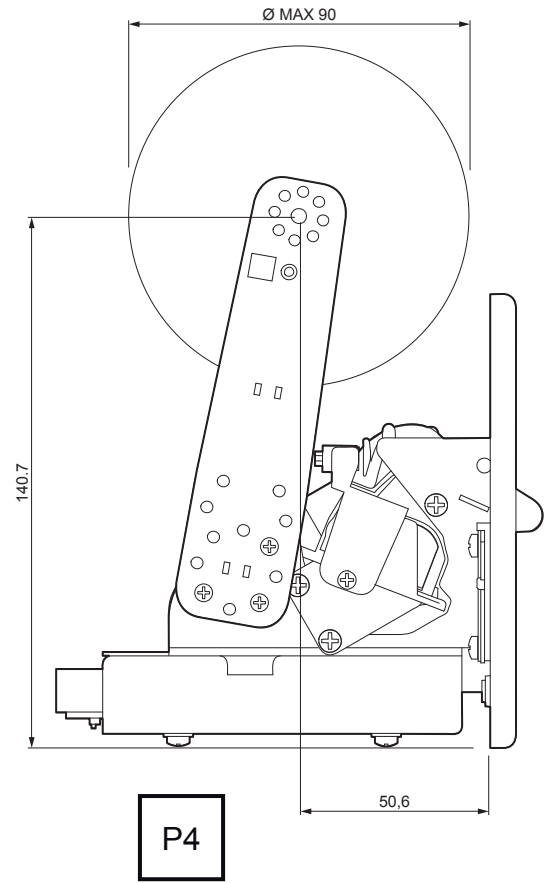
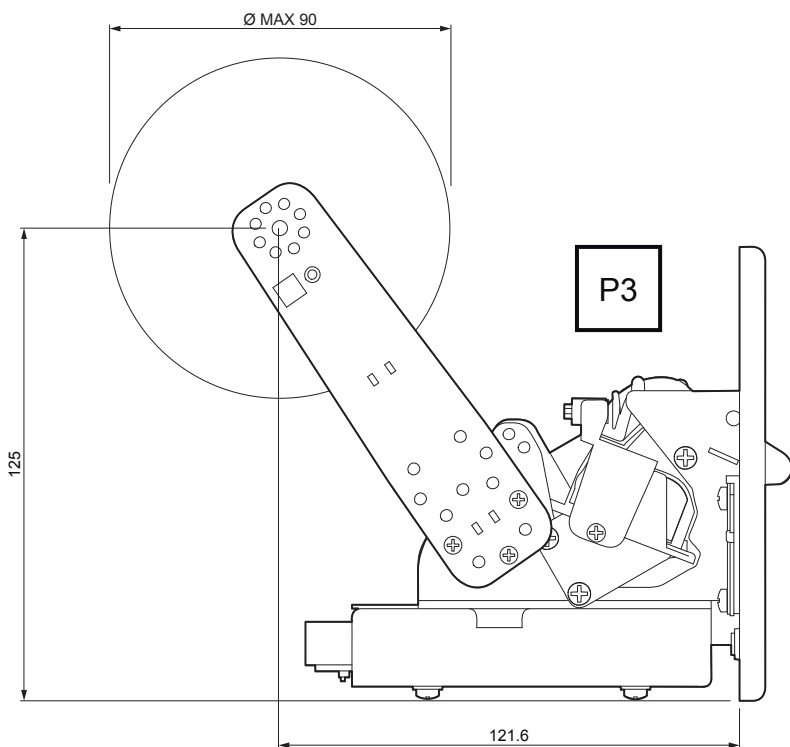
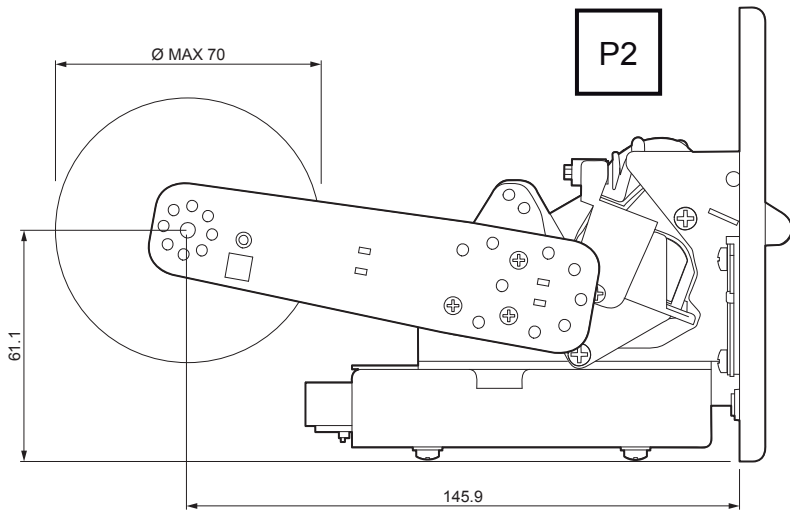
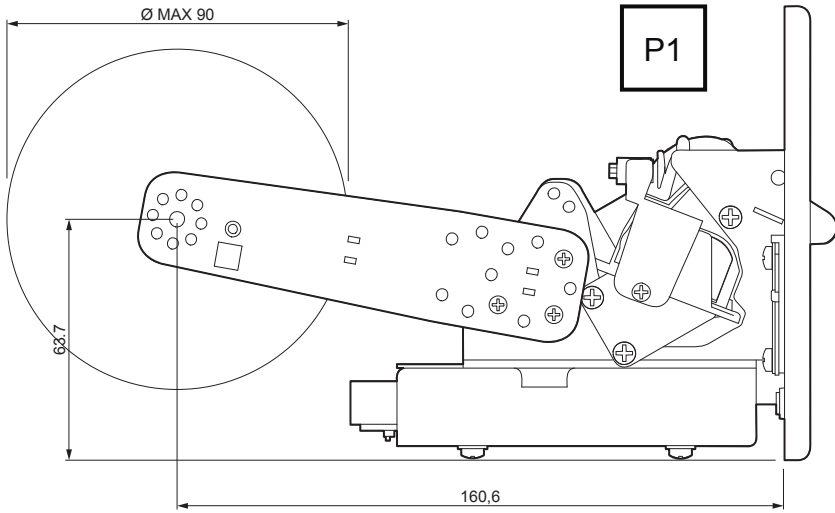

Model with illuminated paper bezel

Length	126.2 mm
Height	85.2 mm
Width	92 mm
Weight	300 g

NOTE:

Dimensions referred to devices without paper roll and without paper roll holder.
All the dimensions shown in following figures are in millimetres.

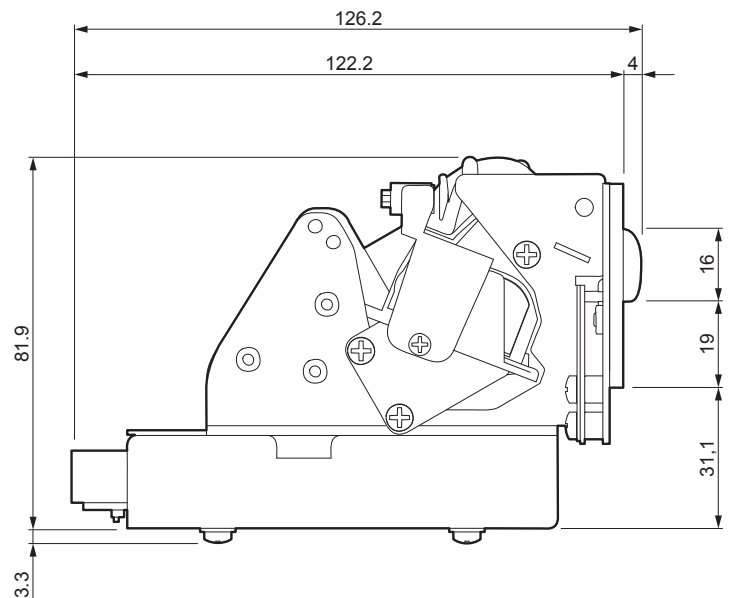
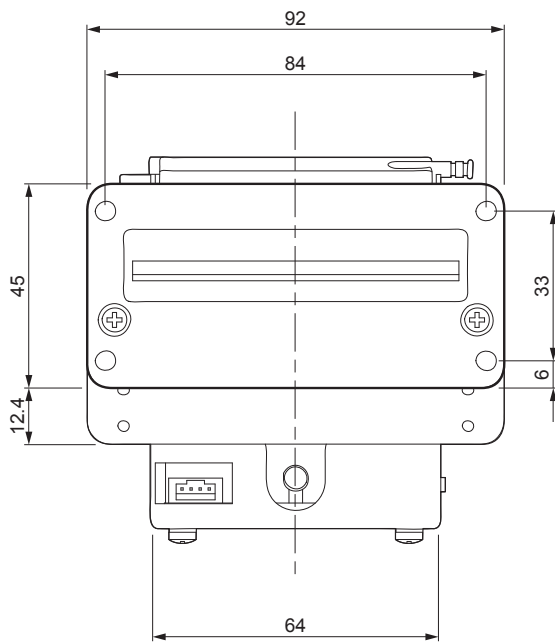

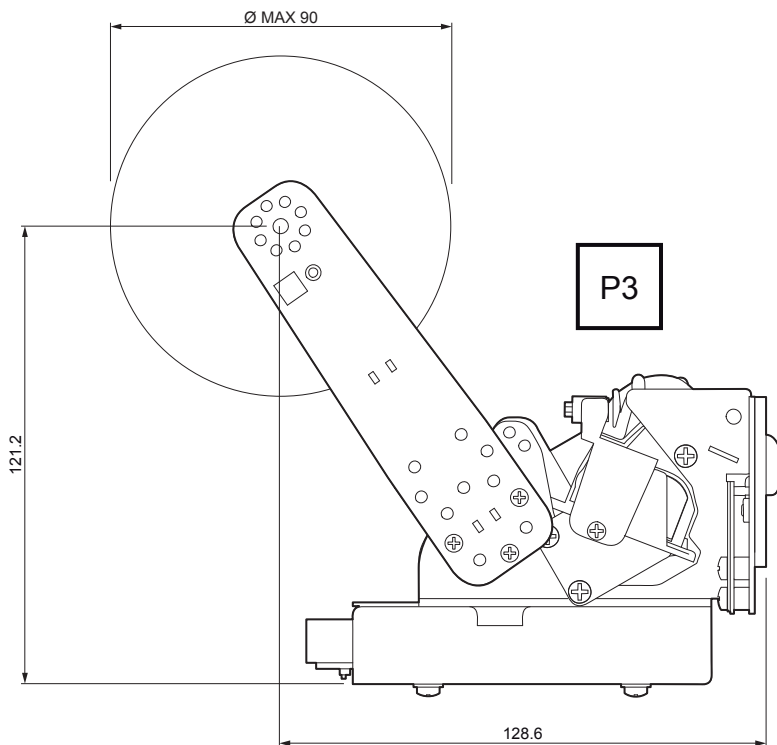
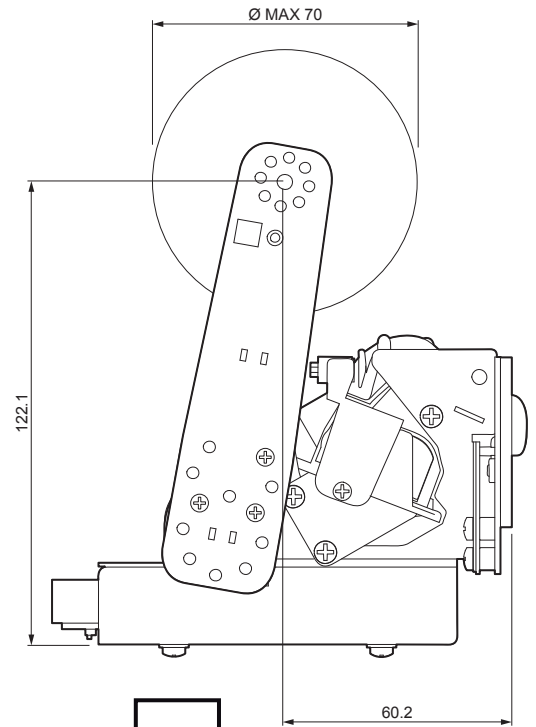
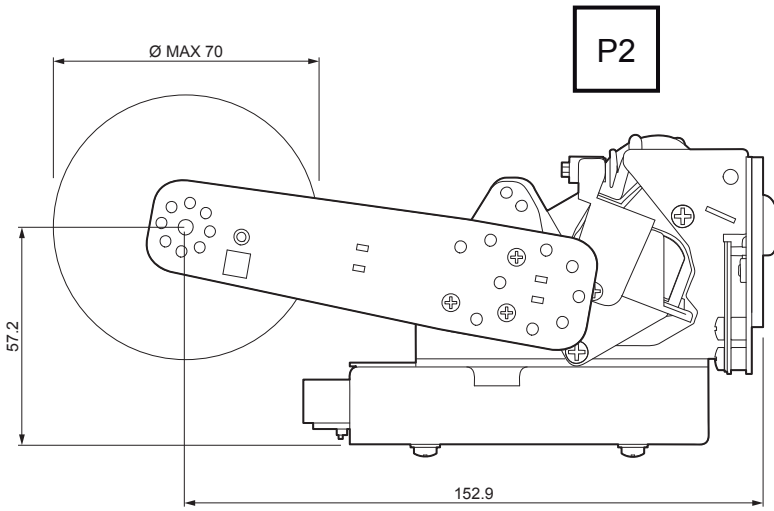
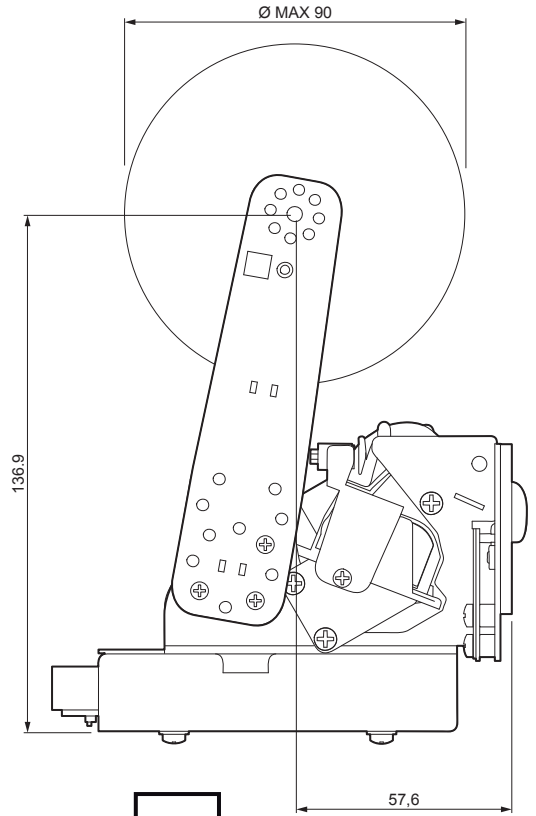
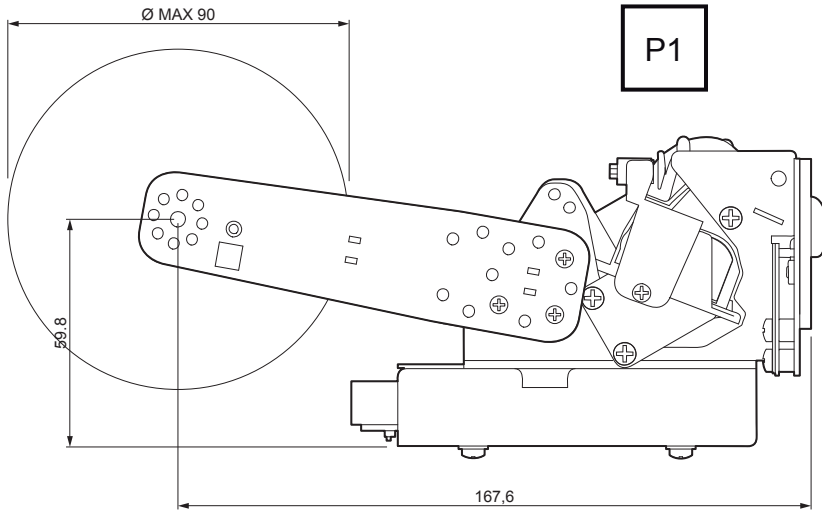

7.4 Character sets in ESC/POS™ emulation

The printer has 3 internal fonts with a width of 12, 16, 22 cpi, which can be associated with one of the coding tables stored on the device.

To know the coding tables actually stored on the device, print the font test (see par.2.4).

The selection of the font and the encoding table is done via command (see the commands manual of the device) or through the Setup procedure by properly setting the parameter “Chars / Inch”, “Code Table” and “Font Type” (see par. 5.4).

The following is the complete list of coding tables that can be installed on the device.

<CodeTable>	Character Tables	
0	PC437 - U.S.A., Standard Europe	
1	Katakana	
2	PC850 - Multilingual	
3	PC860 - Portuguese	
4	PC863 - Canadian/French	
5	PC865 - Nordic	
11	PC851 - Greek	on request
12	PC853 - Turkish	on request
13	PC857 - Turkish	on request
14	PC737 - Greek	on request
15	ISO8859-7 - Greek	on request
16	WPC1252	
17	PC866 - Cyrillic 2	
18	PC852 - Latin 2	on request
19	PC858 for Euro symbol at position 213	
20	KU42 - Thai	on request
21	TIS11 - Thai	on request
26	TIS18 - Thai	on request
30	TCVN_3 - Vientamese	on request
31	TCVN_3 - Vientamese	on request
32	PC720 - Arabic	on request

<CodeTable>	Character Tables	
33	WPC775 - Baltic Rim	on request
34	PC855 - Cyrillic	on request
35	PC861 - Icelandic	on request
36	PC862 - Hebrew	
37	PC864 - Arabic	
38	PC869 - Greek	on request
39	ISO8859-2 - Latin 2	on request
40	ISO8859-15 - Latin 9	on request
41	PC1098 - Farci	on request
42	PC1118 - Lithuanian	on request
43	PC1119 - Lithuanian	on request
44	PC1125 - Ukranian	on request
45	WPC1250 - Latin 2	
46	WPC1251 - Cyrillic	
47	WPC1253 - Greek	
48	WPC1254 - Turkish	
49	WPC1255 - Hebrew	
50	WPC1256 - Arabic	
51	WPC1257 - Baltic Rim	
52	WPC1258 - Vientamese	
53	KZ1048 - Kazakhstan	on request
255	Space page	

8 CONSUMABLES

The following table shows the list of available consumables for device:

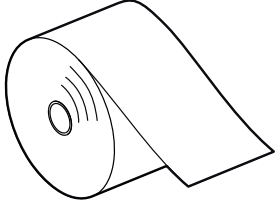
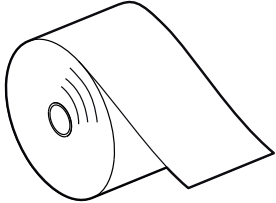
DESCRIPTION	CODE
<p>THERMAL PAPER ROLL</p> <p>weight = 58g/m² width = 57mm Ø external = 50mm Ø core = 12mm</p>	<p>67300000000344</p> 
<p>THERMAL PAPER ROLL BACK PRINTED WITH "CUSTOM" LOGO</p> <p>weight = 58g/m² width = 57mm Ø external = 70mm Ø core = 12mm</p>	<p>67300000000349</p> 

9 ACCESSORIES

The following table shows the list of available accessories for device:

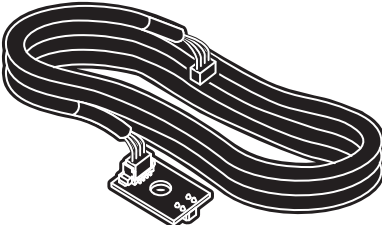
DESCRIPTION	CODE
SERIAL CABLE RJ-DB9F Length = 1.5 m	26500000000311 
NEAR PAPER END SENSOR KIT Length = 23 cm	976HZ010000001 

10 TECHNICAL SERVICE

In case of failure, contact the Technical Service by sending an e-mail to support@custom.it detailing:

1. Product code
2. Serial number
3. Hardware release
4. Firmware release

To get the necessary data, proceed as follows:

1

XXXXXXXXXXXXXXXXX Rx



00000000000000000000

Write down the data printed on the product label (see paragraph 2.3)

2

FW

TG02H printer	
SCODE <code>	- rel 1.00
FCODE <code>	- rel 1.00

PRINTER SETTINGS

PRINTER TYPETG02H
PRINTING HEAD TYPEKF2002
INTERFACERS232
PROGRAM MEMORY TEST.....OK
DYNAMIC RAM TEST.....OK

Print a Setup report (see paragraph 5.1)
The Setup report shows the firmware release

3



↓

support@custom.it
Customer Service Department

Send an e-mail to the Technical Service, with the data collected

CUSTOM[®]

CUSTOM S.p.A.

World Headquarters

Via Berettine, 2/B - 43010 Fontevivo, Parma ITALY

Tel. +39 0521 680111 - Fax +39 0521 610701

info@custom.biz - www.custom.biz

All rights reserved