

USER MANUAL

TG2480HIII

CUSTOM[®]

CUSTOM S.p.A.
Via Berettine 2/B
43010 Fontevivo (PARMA) - Italy
Tel. : +39 0521-680111
Fax : +39 0521-610701
http: www.custom.biz

Customer Service Department:
www.custom4u.it

© 2022 CUSTOM S.p.A. – Italy.
All rights reserved. Total or partial reproduction of this manual in whatever form, whether by printed or electronic means, is forbidden. While guaranteeing that the information contained in it has been carefully checked, CUSTOM S.p.A. and other entities utilized in the realization of this manual bear no responsibility for how the manual is used. Information regarding any errors found in it or suggestions on how it could be improved are appreciated. Since products are subject to continuous check and improvement, CUSTOM S.p.A. reserves the right to make changes in information contained in this manual without prior notification.

The pre-installed multimedia contents are protected from Copyright CUSTOM S.p.A. Other company and product names mentioned herein may be trademarks of their respective companies. Mention of third-party products is for informational purposes only and constitutes neither an endorsement nor a recommendation. CUSTOM S.p.A. assumes no responsibility with regard to the performance or use of these products.

THE IMAGES USED IN THIS MANUAL ARE USED AS AN ILLUSTRATIVE EXAMPLES. THEY COULDN'T REPRODUCE THE DESCRIBED MODEL FAITHFULLY.

UNLESS OTHERWISE SPECIFIED, THE INFORMATION GIVEN IN THIS MANUAL ARE REFERRED TO ALL MODELS IN PRODUCTION AT THE ISSUE DATE OF THIS DOCUMENT.

GENERAL INSTRUCTIONS

CUSTOM S.p.A. declines all responsibility for accidents or damage to persons or property occurring as a result of tampering, structural or functional modifications, unsuitable or incorrect installations, environments not in keeping with the equipment's protection degree or with the required temperature and humidity conditions, failure to carry out maintenance and periodical inspections and poor repair work.

GENERAL SAFETY INFORMATION

Your attention is drawn to the following actions that could compromise the characteristics of the product:

- Read and retain the instructions which follow.
- Follow all indications and instructions given on the device.
- Make sure that the surface on which the device rests is stable. If it is not, the device could fall, seriously damaging it.
- Make sure that the device rests on a hard (non-padded) surface and that there is sufficient ventilation.
- Do not fix indissolubly the device or its accessories such as power supplies unless specifically provided in this manual.
- When positioning the device, make sure cables do not get damaged.
- [Only OEM equipment] The equipment must be installed in a kiosk or system that provides mechanical, electrical and fire protection.
- The mains power supply must comply with the rules in force in the Country where you intend to install the equipment.
- Make sure that there is an easily-accessible outlet with a capacity of no less than 10A closely to where the device is to be installed.
- Make sure the power cable provided with the appliance, or that you intend to use is suitable with the wall socket available in the system.
- Make sure the electrical system that supplies power to the device is equipped with a ground wire and is protected by a differential switch.
- Before any type of work is done on the machine, disconnect the power supply.
- Use the type of electrical power supply indicated on the device label.
- These devices are intended to be powered by a separately certified power module having an SELV, non-energy hazardous output. (IEC60950-1 second edition).
- [Only POS equipment] The energy to the equipment must be provided by power supply approved by CUSTOM S.p.A.
- Take care the operating temperature range of equipment and its ancillary components.
- Do not block the ventilation openings.
- Do not insert objects inside the device as this could cause short-circuiting or damage components that could jeopardize printer functioning.
- Do not carry out repairs on the device yourself, except for the normal maintenance operations given in the user manual.
- The equipment must be accessible on these components only to trained, authorized personnel.
- Periodically perform scheduled maintenance on the device to avoid dirt build-up that could compromise the correct, safe operation of the unit.
- Do not touch the head heating line with bare hands or metal objects. Do not perform any operation inside the printer immediately after printing because the head and motor tend to become very hot.
- Use consumables approved by CUSTOM S.p.A.



THE CE MARK AFFIXED TO THE PRODUCT CERTIFY THAT THE PRODUCT SATISFIES THE BASIC SAFETY REQUIREMENTS.

The device is in conformity with the essential Electromagnetic Compatibility and Electric Safety requirements laid down in Directives 2014/30/EU and 2014/35/EU inasmuch as it was designed in conformity with the provisions laid down in the following Standards:

- EN 55032 (*Electromagnetic compatibility of multimedia equipment - Emission Requirements*)
- EN 55024/EN55035 (*Electromagnetic compatibility of multimedia equipment - Immunity requirements*)
- EN IEC/EN62368-1 (*Audio/video, information and communication technology equipment*)

The device is in conformity with the essential requirements laid down in Directives 2014/53/EU about devices equipped with intentional radiators. The Declaration of Conformity and other available certifications can be downloaded from the site www.custom4u.it.



GUIDELINES FOR THE DISPOSAL OF THE PRODUCT

The crossed-out rubbish bin logo means that used electrical and electronic products shall NOT be mixed with unsorted municipal waste. For more detailed information about recycling of this product, refer to the instructions of your country for the disposal of these products.

- Do not dispose of this equipment as miscellaneous solid municipal waste, but arrange to have it collected separately.
- The re-use or correct recycling of the electronic and electrical equipment (EEE) is important in order to protect the environment and the wellbeing of humans.
- In accordance with European Directive WEEE 2012/19/EU, special collection points are available to which to deliver waste electrical and electronic equipment and the equipment can also be handed over to a distributor at the moment of purchasing a new equivalent type.
- The public administration and producers of electrical and electronic equipment are involved in facilitating the processes of the re-use and recovery of waste electrical and electronic equipment through the organisation of collection activities and the use of appropriate planning arrangements.
- Unauthorised disposal of waste electrical and electronic equipment is punishable by law with the appropriate penalties.



The format used for this manual improves use of natural resources reducing the quantity of necessary paper to print this copy.

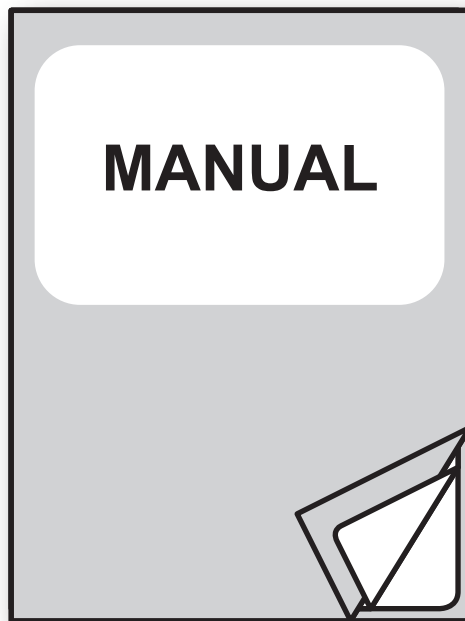

For details on the commands,
refer to the manual with code **77200000005200**

For further information about the use of “PrinterSet” tool
refer to the manual with code **78200000001800**

TABLE OF CONTENTS

1	INTRODUCTION	9
2	DESCRIPTION	11
2.1	Box contents	11
2.2	Device components	12
2.3	Product label	13
2.4	Key functions: power up	14
2.5	Key functions: standby	15
2.6	Status messages	16
3	INSTALLATION	17
3.1	Panel fastening	17
3.2	Paper roll holder assembly	18
3.3	Connections	20
3.4	Pinout	21
3.5	Driver and SDK	23
4	OPERATION	25
4.1	Device opening	25
4.2	Device closing	27
4.3	Adjusting paper width	29
4.4	Adjusting paper stock	30
4.5	Switch the device on	31
4.6	Loading the paper roll	32
4.7	Anti-jamming system	34
5	CONFIGURATION	35
5.1	Configuration by keys	35
5.2	Configuration by software	37
5.3	Device status	39
5.4	Communication parameters	40
5.5	Operating parameters	42
5.6	Alignment parameters	45
5.7	Hexadecimal dump	47

6	ALIGNMENT	49
6.1	Calibration.....	50
6.2	Alignment parameters.....	52
6.3	Printing area	55
7	MAINTENANCE	57
7.1	Paper jam	57
7.2	Planning of cleaning operations	60
7.3	Cleaning	61
7.4	Firmware upgrade.....	65
8	SPECIFICATION	67
8.1	Hardware specifications	67
8.2	Character specifications	70
8.3	Device dimensions	70
8.4	Power supply, power cord and adapter for power supply dimensions	72
8.5	Paper specification	74
8.6	Character sets	75
9	CONSUMABLES	77
10	ACCESSORIES	79
11	TECHNICAL SERVICE	81



1 INTRODUCTION

This document is divided into sections and chapters. Each chapter can be reached by the index at the beginning of this document. The index can be reached by the button on each page as shown in the diagram below.

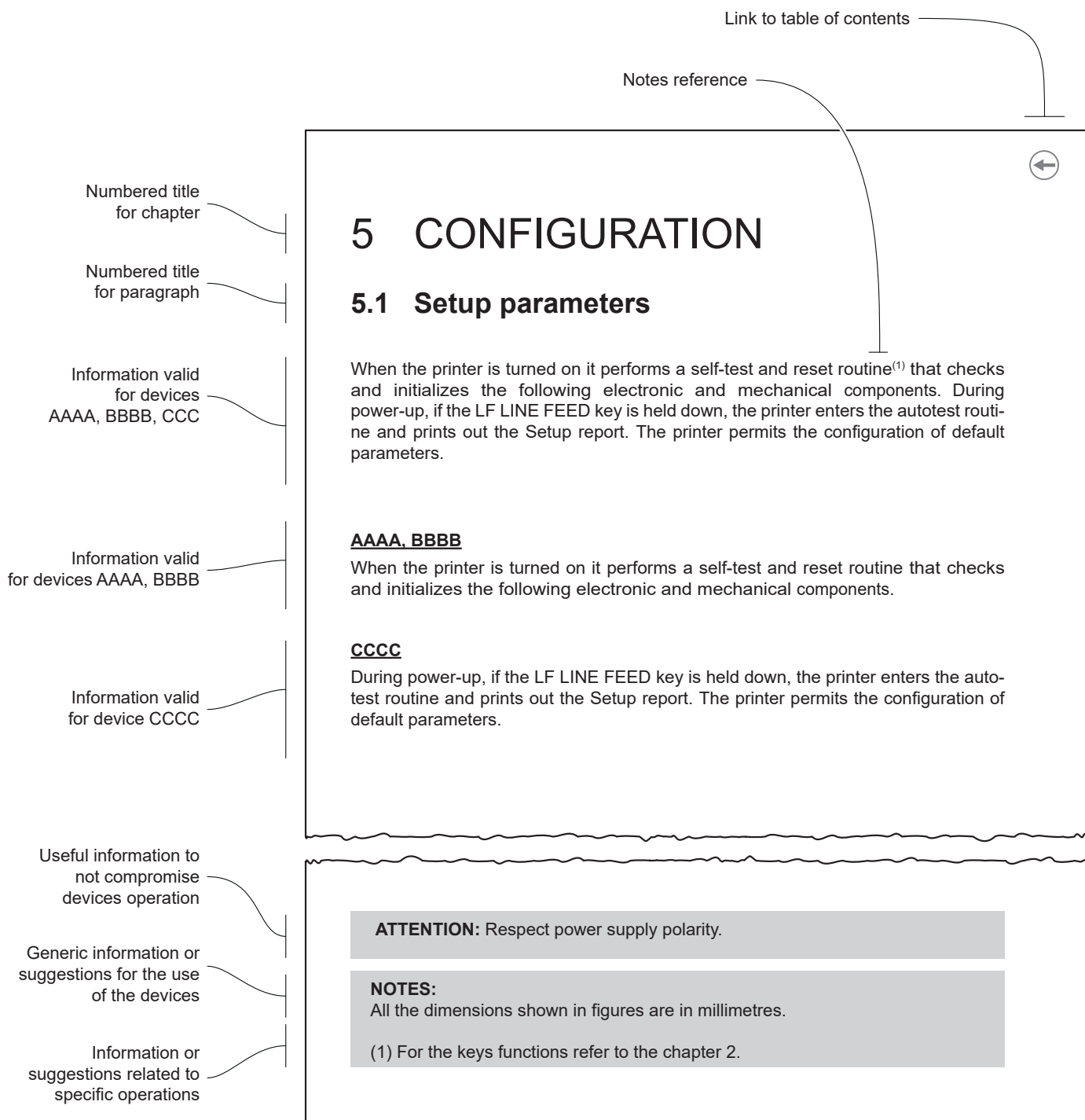





2 DESCRIPTION

2.1 Box contents

Remove the device from its carton being careful not to damage the packing material so that it may be re-used if the device is to be transported in the future.

Make sure that all the components illustrated below are present and that there are no signs of damage. If there are, contact customer service

1. Power supply cable
2. Paper roll holder fixing screw (x2)
3. Documentation (installation instruction sheet)
4. Cable tie (x2)
5. Device
6. Paper roll holder

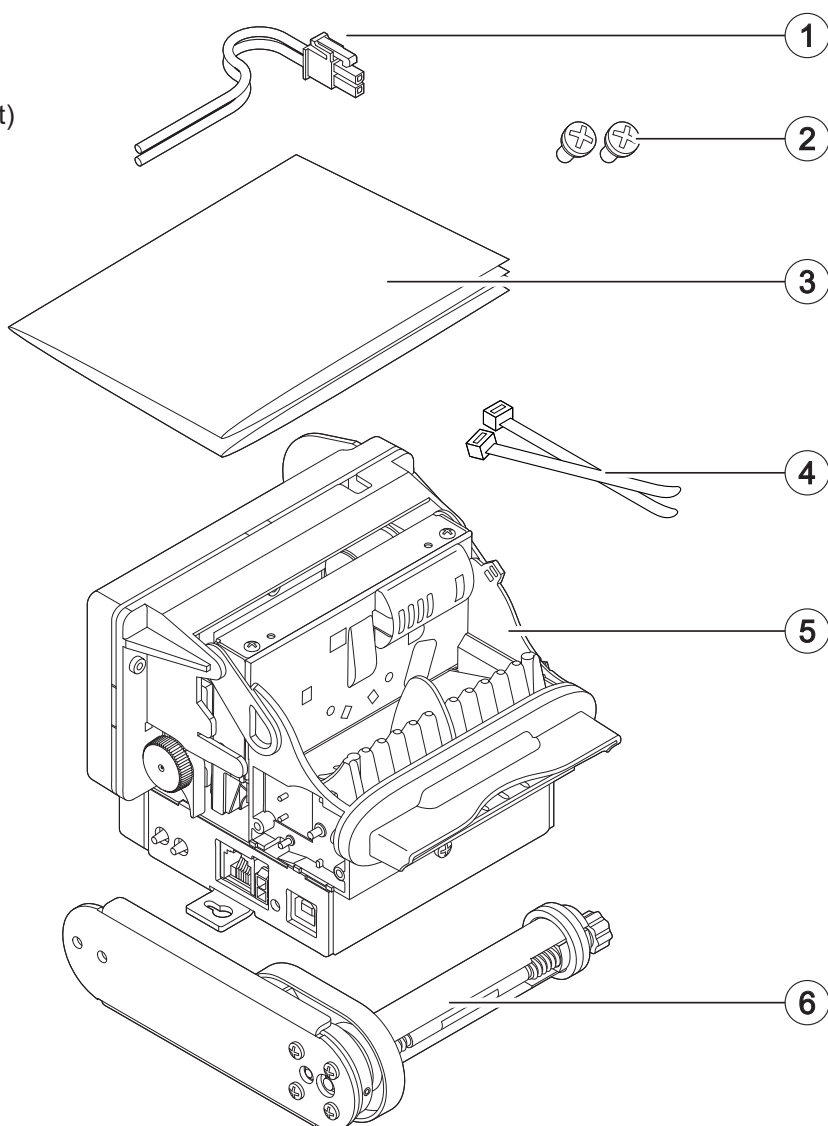



2.2 Device components

1. Paper width adjustment
2. Paper roll holder pin
3. Low paper sensor
4. Lever for paper stock adjustment
5. Paper roll holder
6. Printing head
7. Autocutter group
8. Sensor for early withdrawal of the ticket
9. Inspection door
10. Paper out
11. Unlocking hook for autocutter group
12. Device chassis
13. USB port
14. Status LED
15. Power supply port
16. Serial port
17. Paper in
18. Paper in presence and black mark sensor
19. Rear cover
20. Paper jam sensor
21. FEED key
22. PRINT key
23. Service lever
24. Platen roller manual feed

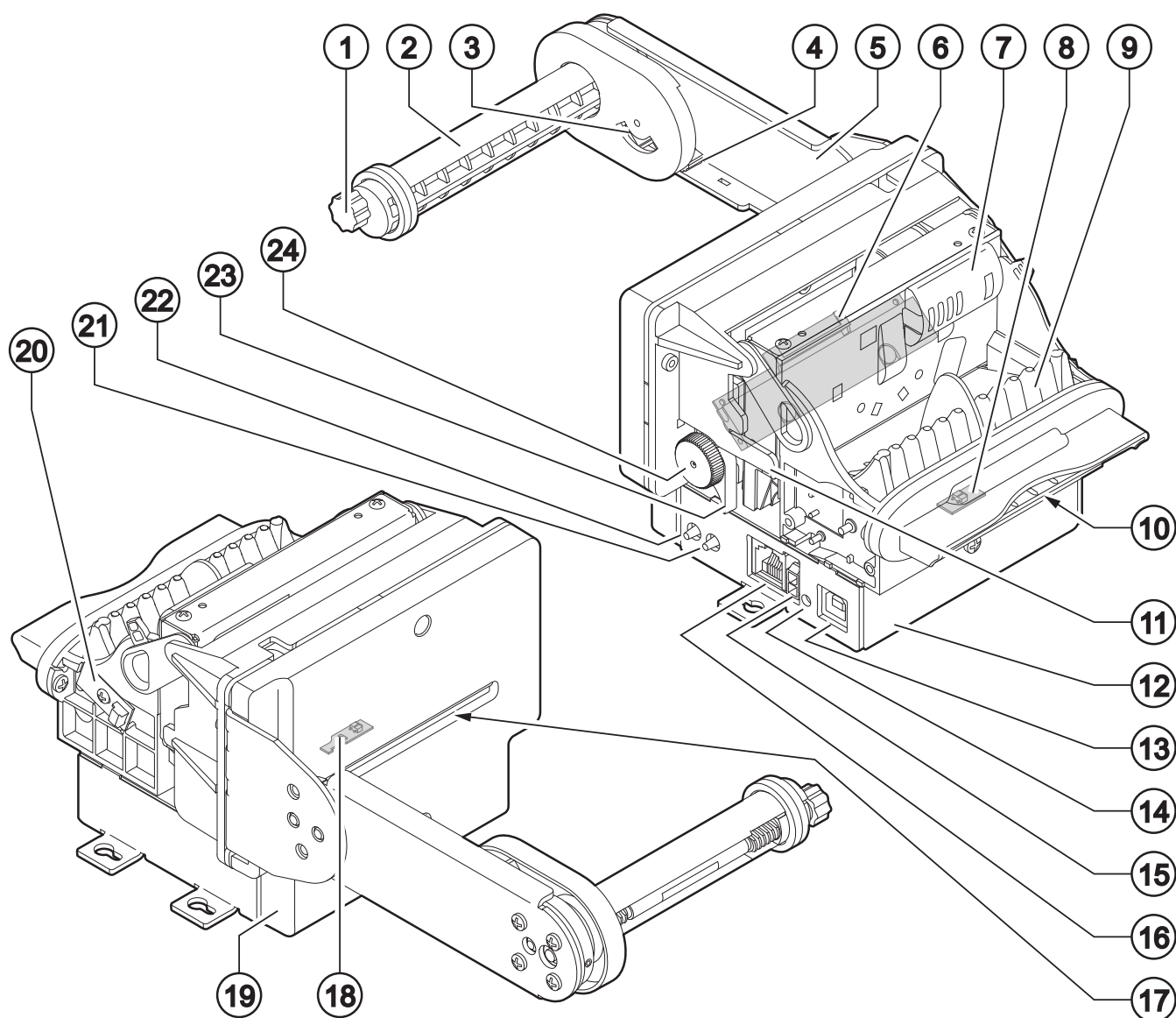



2.3 Product label

The main data used to identify the machine are shown on the label attached to the bottom of the device. In particular, it shows the electrical data for the connection to a power source. It also shows the product code, the serial number and the hardware revision (R).

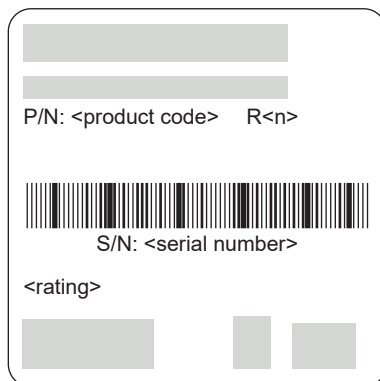

2.4 Key functions: power up

The following figure shows the functions of device's keys according to the operating condition.

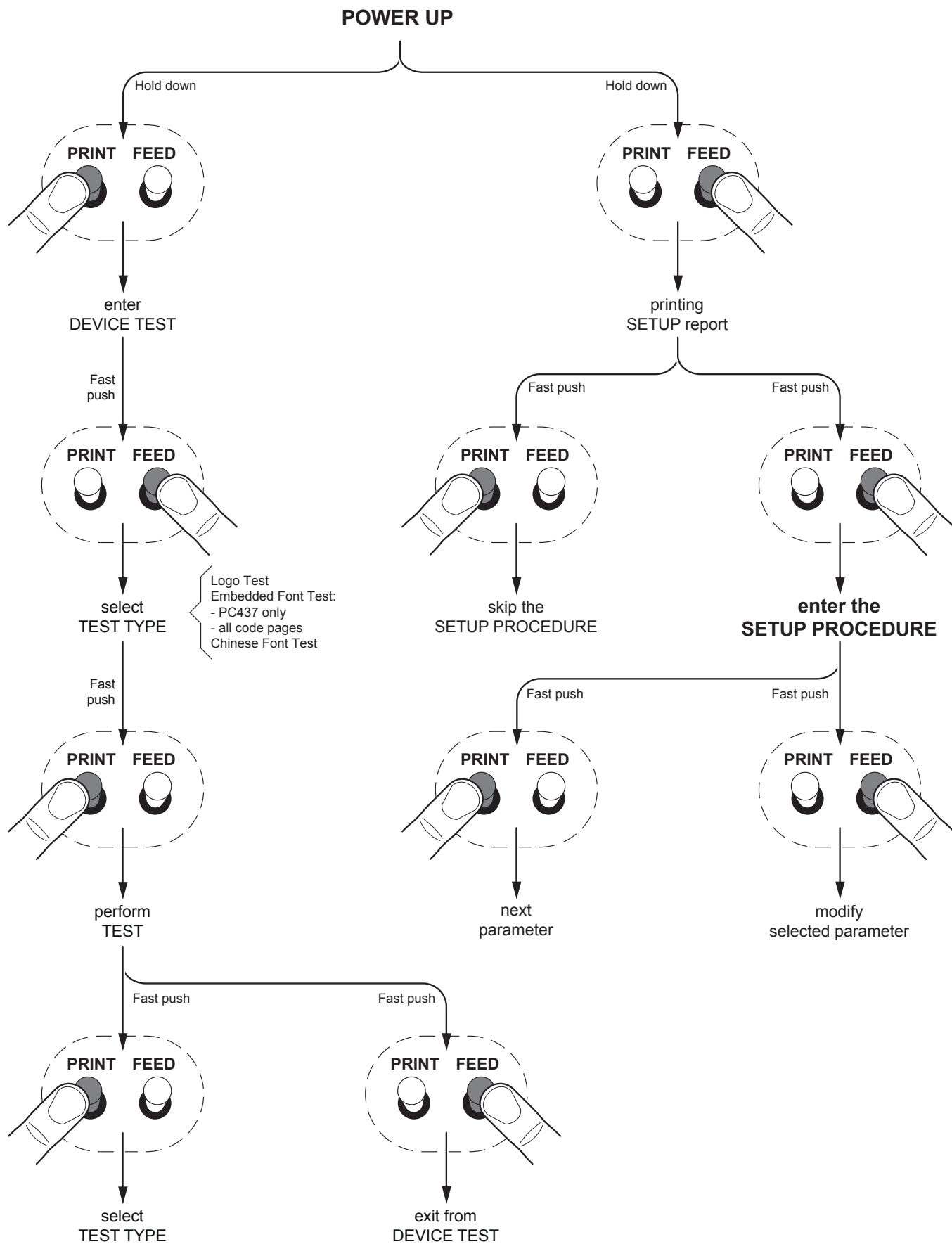



2.5 Key functions: standby

The following figure shows the functions of device's keys according to the operating condition.

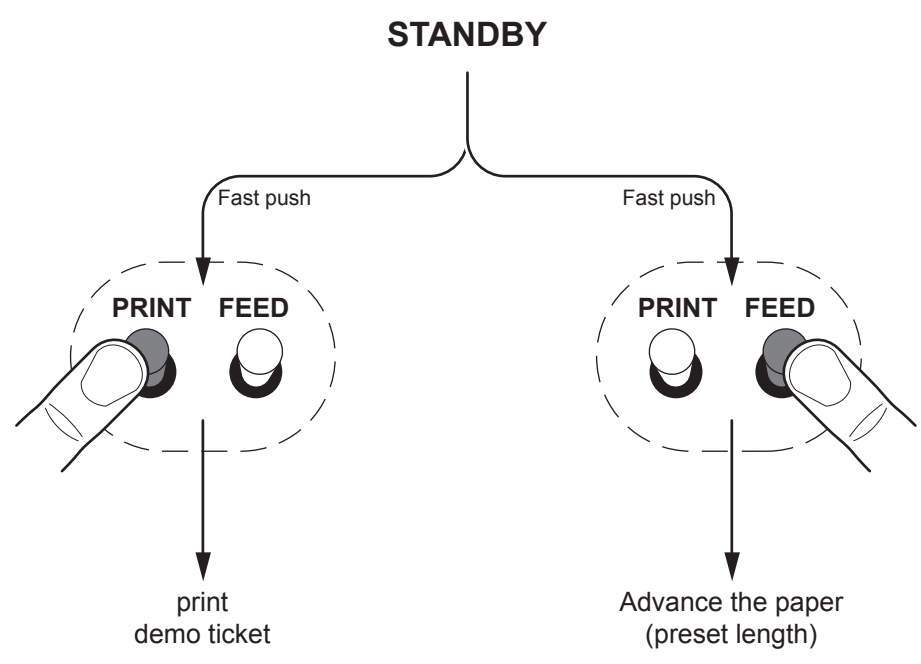



2.6 Status messages

The status LED indicates hardware status of device. Given in the table below are the various LED signals and the corresponding device status.

STATUS LED		DESCRIPTION
-	OFF	DEVICE OFF
GREEN	ON	DEVICE ON: NO ERROR
GREEN COMMUNICATION STATUS	x 1	RECEIVE DATA
	x 2	PRINthead OVERHEATED
	x 3	PAPER END
	x 4	POWER SUPPLY VOLTAGE INCORRECT
	x 5	RECEPTION ERROR (PARITY, FRAME ERROR, OVERRUN ERROR)
	x 6	COMMAND NOT RECOGNIZED
	x 7	COMMAND RECEPTION TIME OUT
	x 8	INSPECTION DOOR OPEN
	x 9	PAPER JAM
	x 10	LOW PAPER
GREEN UNRECOVERABLE ERROR	x 11	AUTOCUTTER ERROR



3 INSTALLATION

3.1 Panel fastening

The device is provided with three fixing holes on the bottom of device (see following figure). To fasten the device on a panel, use three M3 screws (not included).

All the dimensions shown in the following figure are in millimetres.

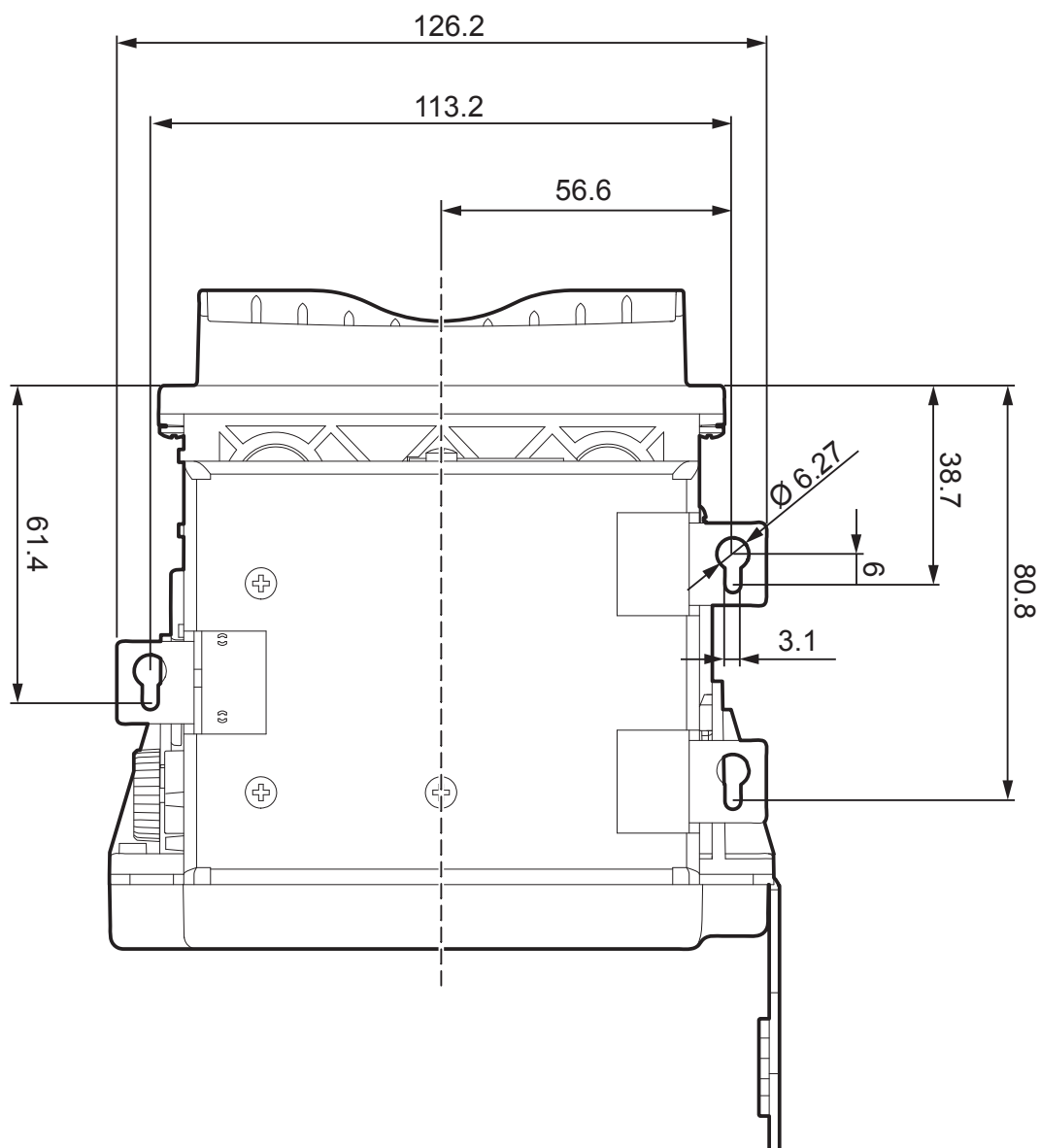

WARNING:

In order to allow the anti-jamming system to operate properly, the device must be mounted on a perfectly horizontal plan.

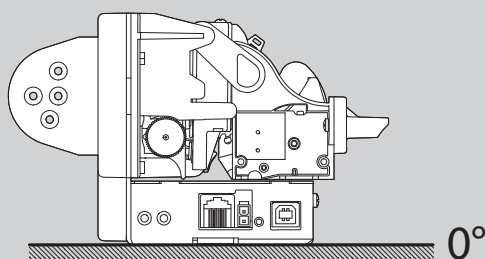



3.2 Paper roll holder assembly

The paper roll holder position is adjustable on four different positions: upper position P1, rotated upward P2, rear P3, rotated downward P4.

Fix the paper roll holder to the device holes shown in figure according to the desired position by using the two M4x6 fixing screws supplied with the device.

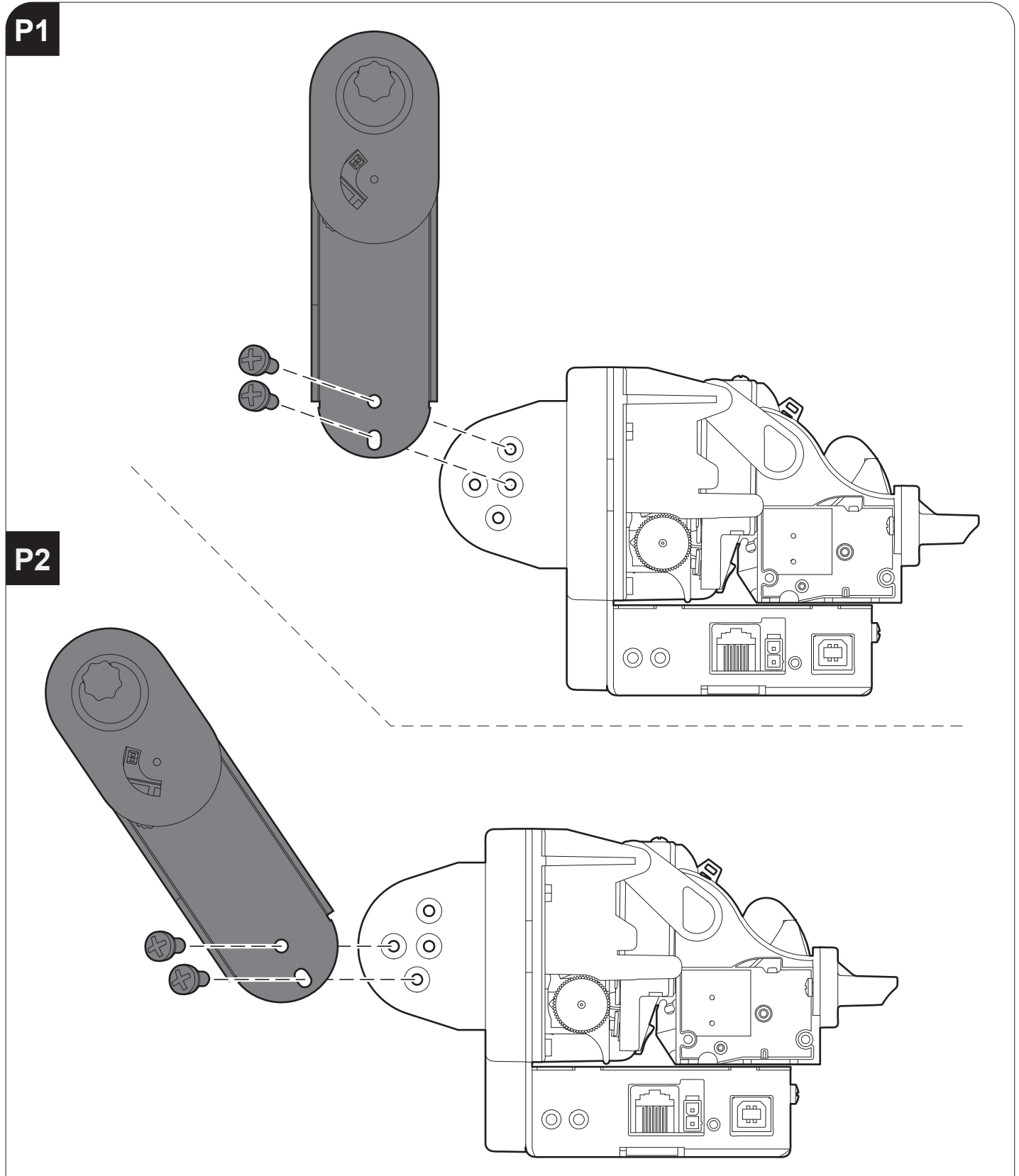

P3

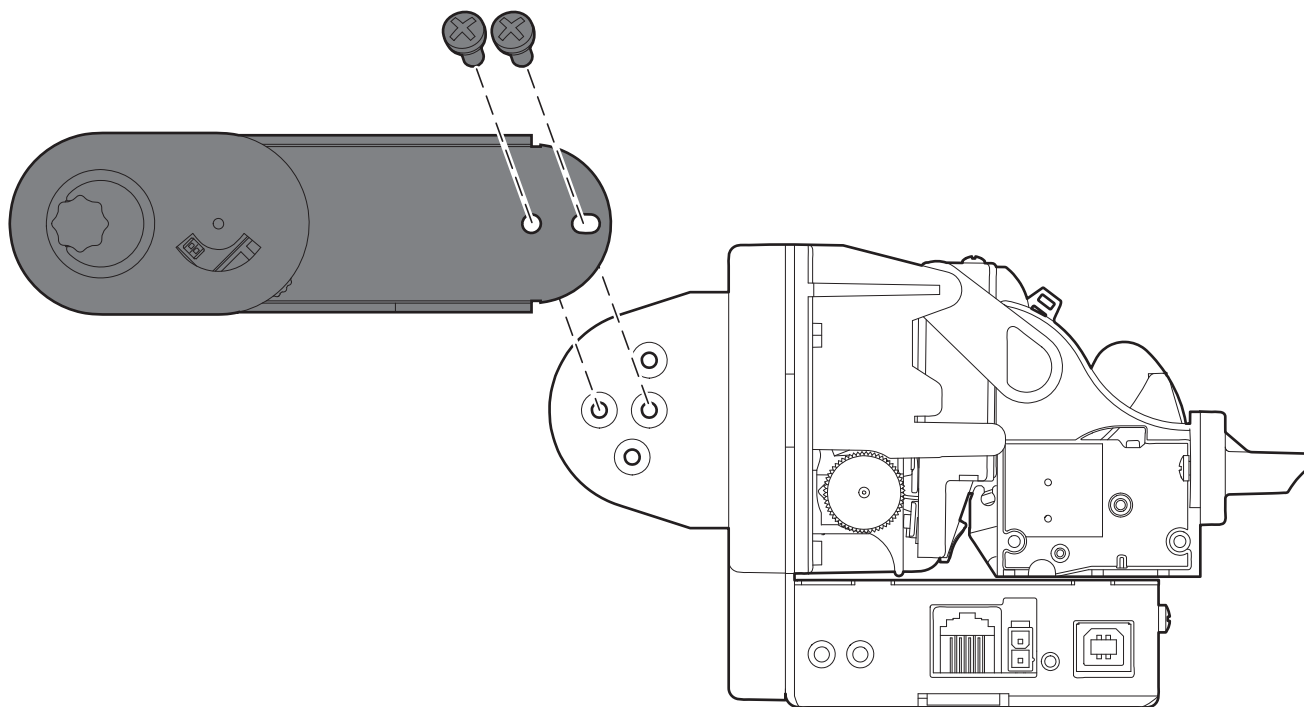

P4

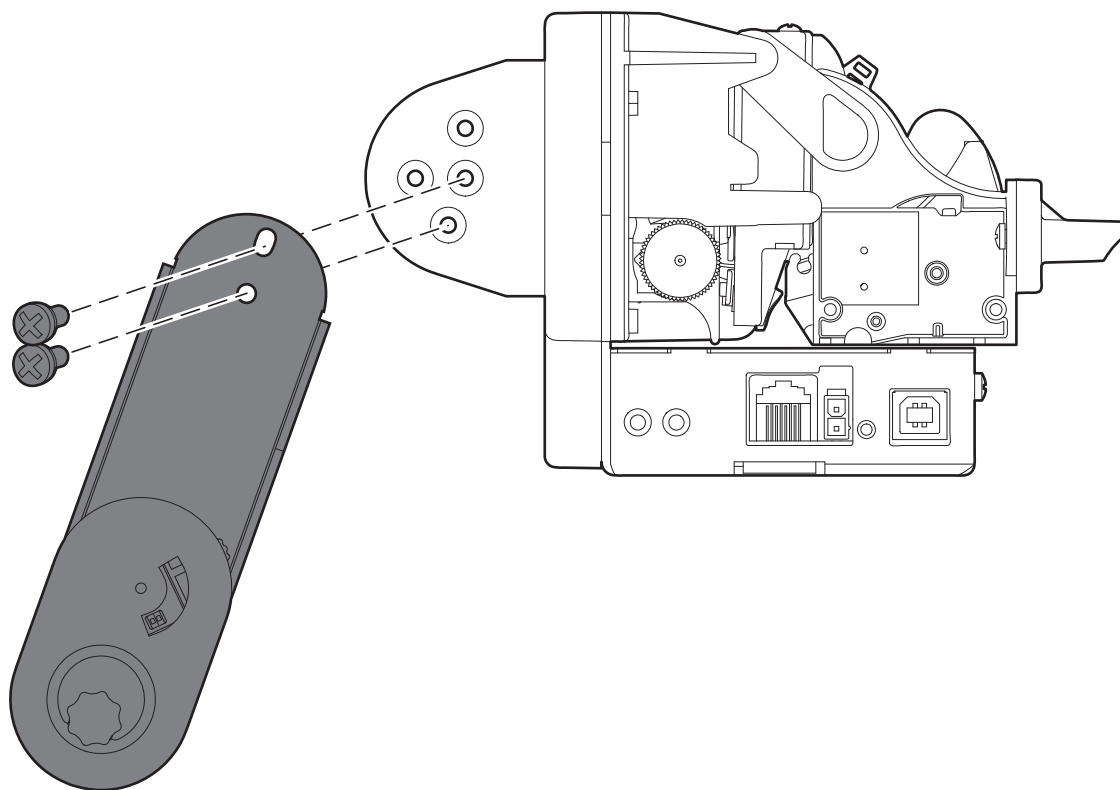

ATTENTION: While assembly the paper roll holder check the cable path (low paper sensor) is correct. Incorrect positions of the cable could cause damage on it.



3.3 Connections

The following figure shows the possible connections for the device. When the RS232 and USB communication cables are connected to the device at the same time, the communication take place via the USB port.

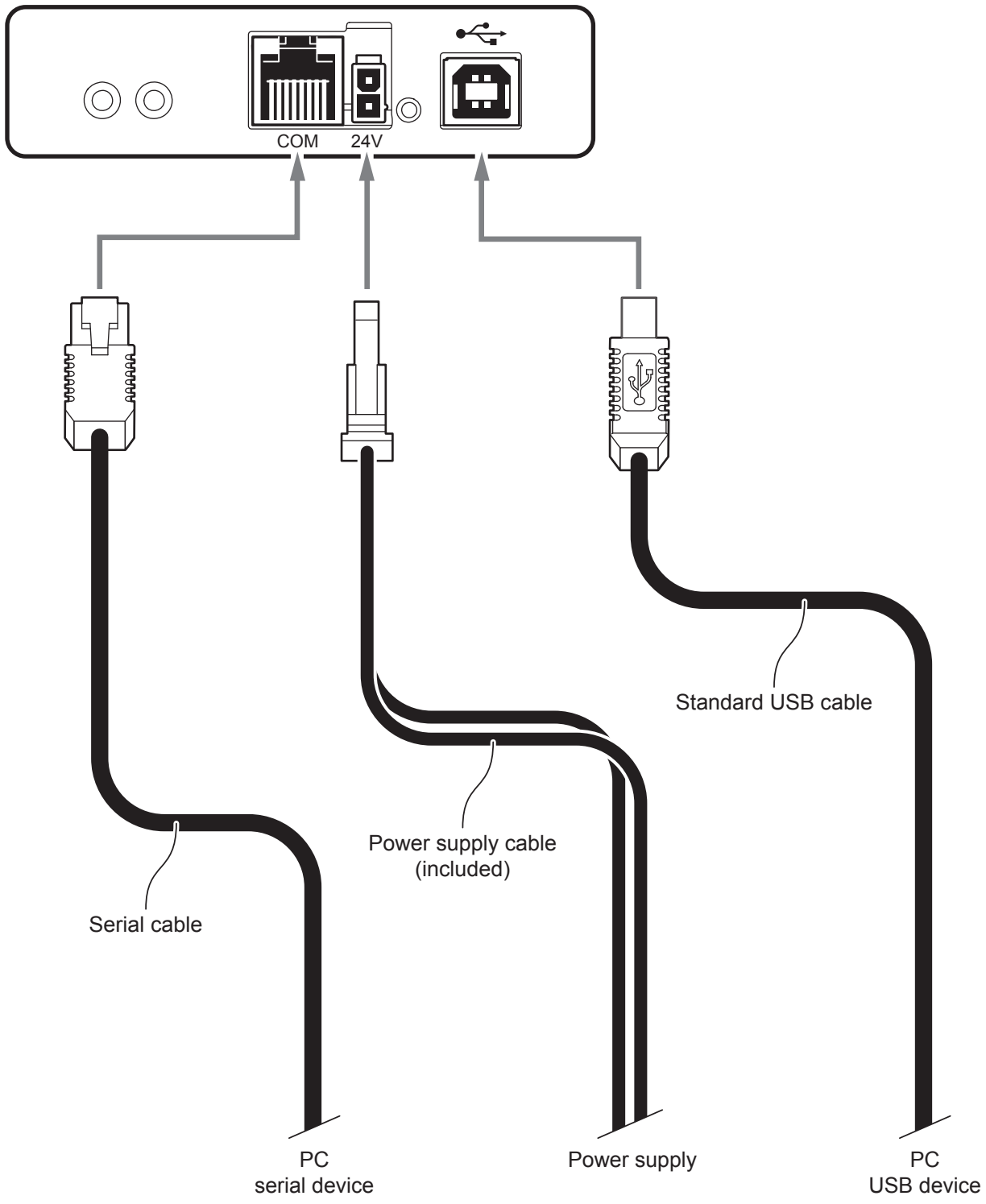

ATTENTION: In some using conditions, we recommend the installation of a ferrite core on the power supply cable.



3.4 Pinout



POWER SUPPLY

Male Molex connector series 5569 vertical (n° 39-30-1020)

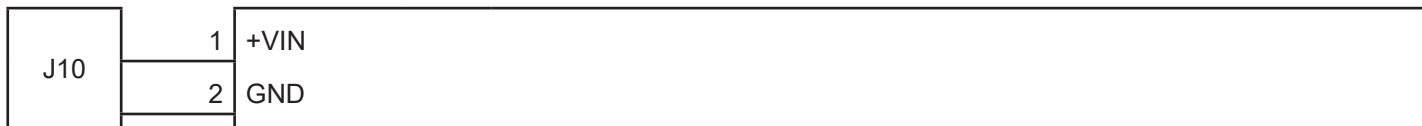

The following figure shows the connector pinout of the power supply cable for the device:

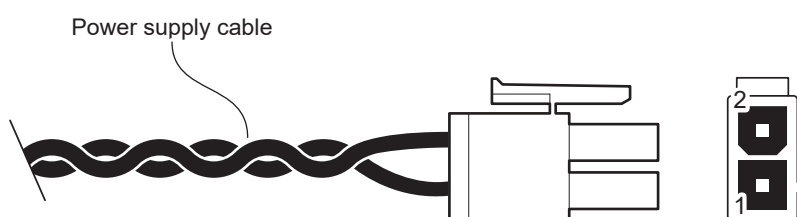

Female Molex connector series 5557 (n.39-01-3022)

PIN	Cable color	Signal
1	Red	+24 V
2	Black	GND

ATTENTION:
Respect power supply polarity.

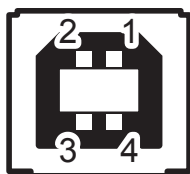

USB INTERFACE

Female USB type B connector





SERIAL INTERFACE

Female RJ45 connector

J2	1	n.c.	
	2	GND	
	3	TX	(out) During transmission, takes the values -VRS232 and +VRS232 depending on data
	4	RX	(in) During reception, takes the values -VRS232 and +VRS232 depending on data
	5	RT	(out) When +VRS232, device is ready to receive data
	6	n.c.	
	7	n.c.	
	8	n.c.	

Given the presence of the RS232 standard, logic value "0" corresponds to the voltage value +VRS232 (voltage value between +3Vdc and +15Vdc) and logic value "1" corresponds to the voltage value -VRS232 (voltage value between -3Vdc and -15Vdc).

DEVICE > PC connection

The following picture shows an example of connection between the device and a personal computer using an 8 pin serial RJ45 male connector and a 9 pin female connector.

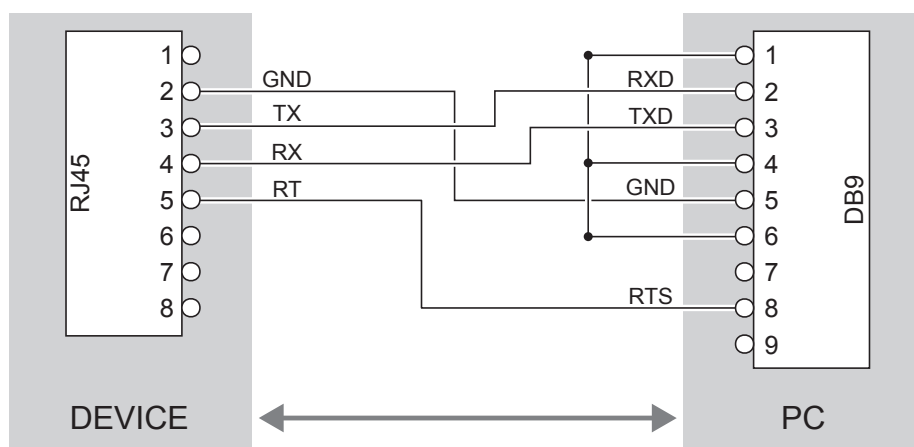

When use a serial cable, we recommend the installation of a ferrite core on the power supply cable.



3.5 Driver and SDK

In the website www.custom4u.it are available the drivers for the following operating system:

OPERATING SYSTEM	DESCRIPTION	INSTALLATION PROCEDURE
Windows	Driver for Windows XP	From the Start menu, press Run and type-in the path where the SW was saved on PC, then click OK. Follow the instructions on the screen to install the driver.
	Driver for Windows VISTA (32/64 bit)	
	Driver for Windows 7 (32/64 bit)	
	Driver for Windows 8 (32/64 bit)	
	Driver for Windows 8.1 (32/64 bit)	
	Driver for Windows 10 (32/64 bit)	
	Self-installing driver for Virtual COM (32/64 bit) (see paragraph 5.4)	
JavaPos library		
Linux	32/64 bit	Follow the instruction get back on the "Readme.txt" file. You can find it in the software package downloaded in advance.
	JavaPos library	



4 OPERATION

4.1 Device opening

1

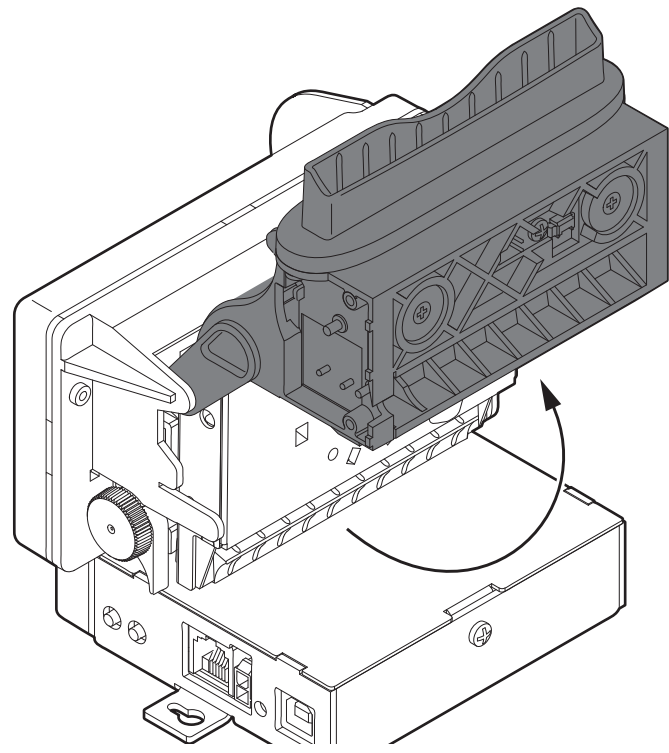

Lift up the ejector group by unhooking the magnets on the bottom side and by rotating the group upwards.

2

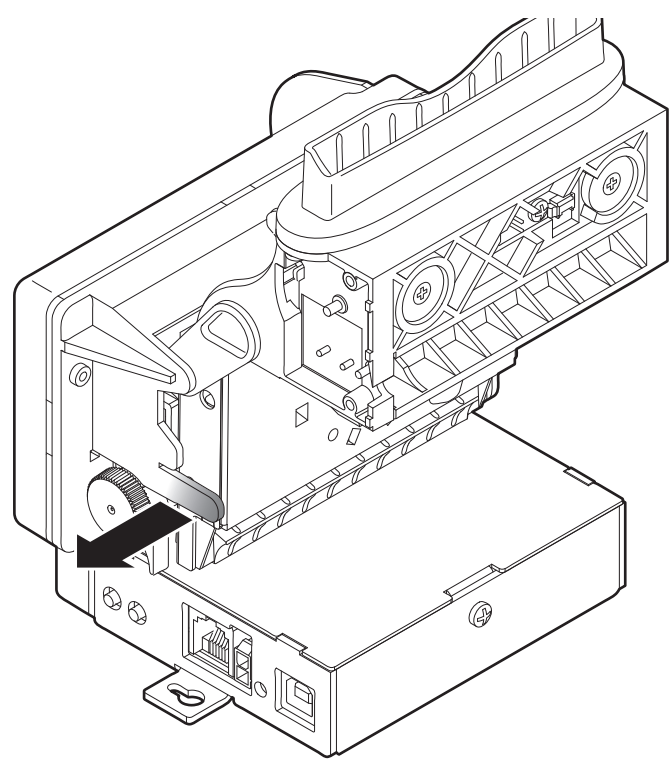

Widen the unlocking hook for the autocutter group.

3

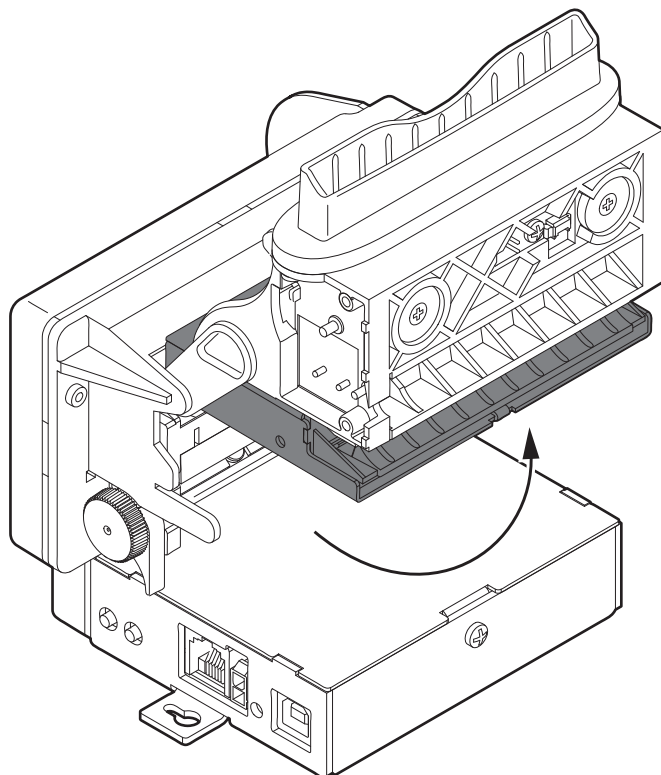

Rotate upwards the autocutter group to lift it up.

4.2 Device closing

1

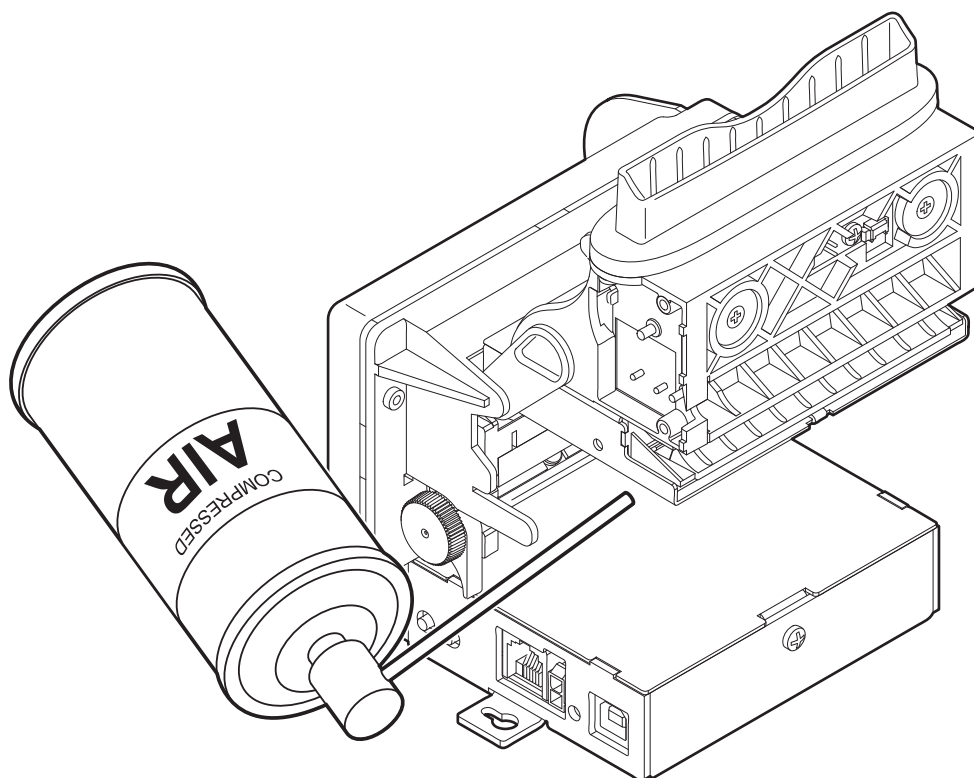

Check the presence of paper scraps and remove them by using compressed air.

2

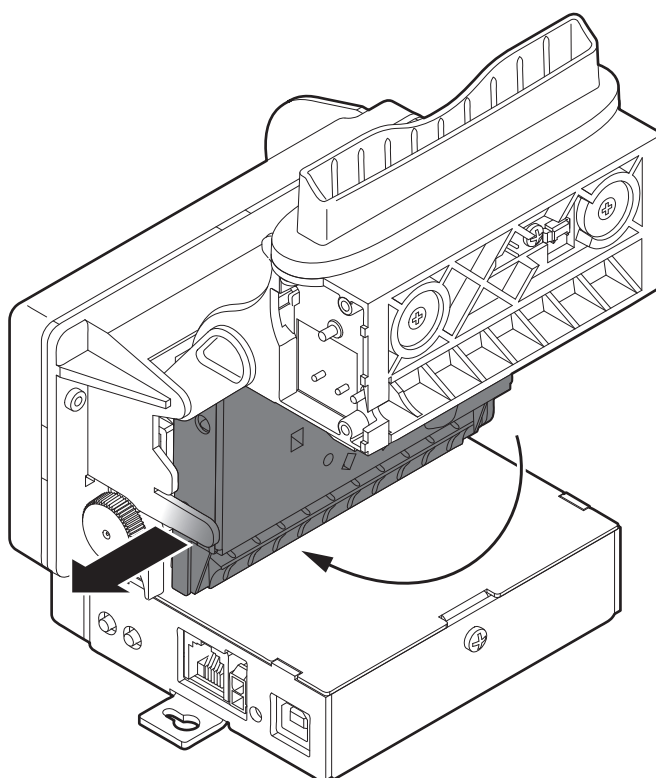

Widen the unlocking hook and close the autocutter group.

3

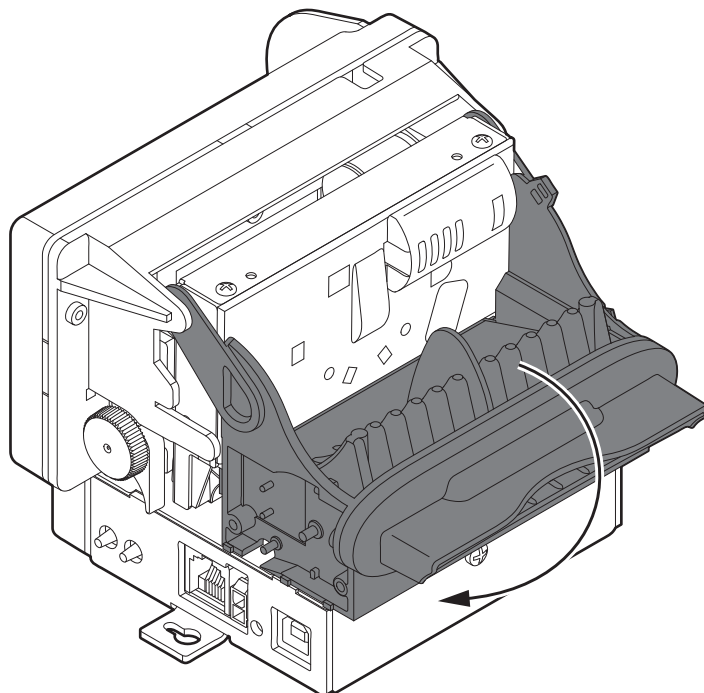

Lower the ejector group and hook the two magnets to the device chassis.

4.3 Adjusting paper width

The device allows the use of paper roll width from 76 mm to 80 mm. Properly set the value of the “Paper Width” parameter during the setup procedure (see [paragraph 5.5](#)). To adjust the width of the paper roll case, rotate the knob as shown in the following figure.

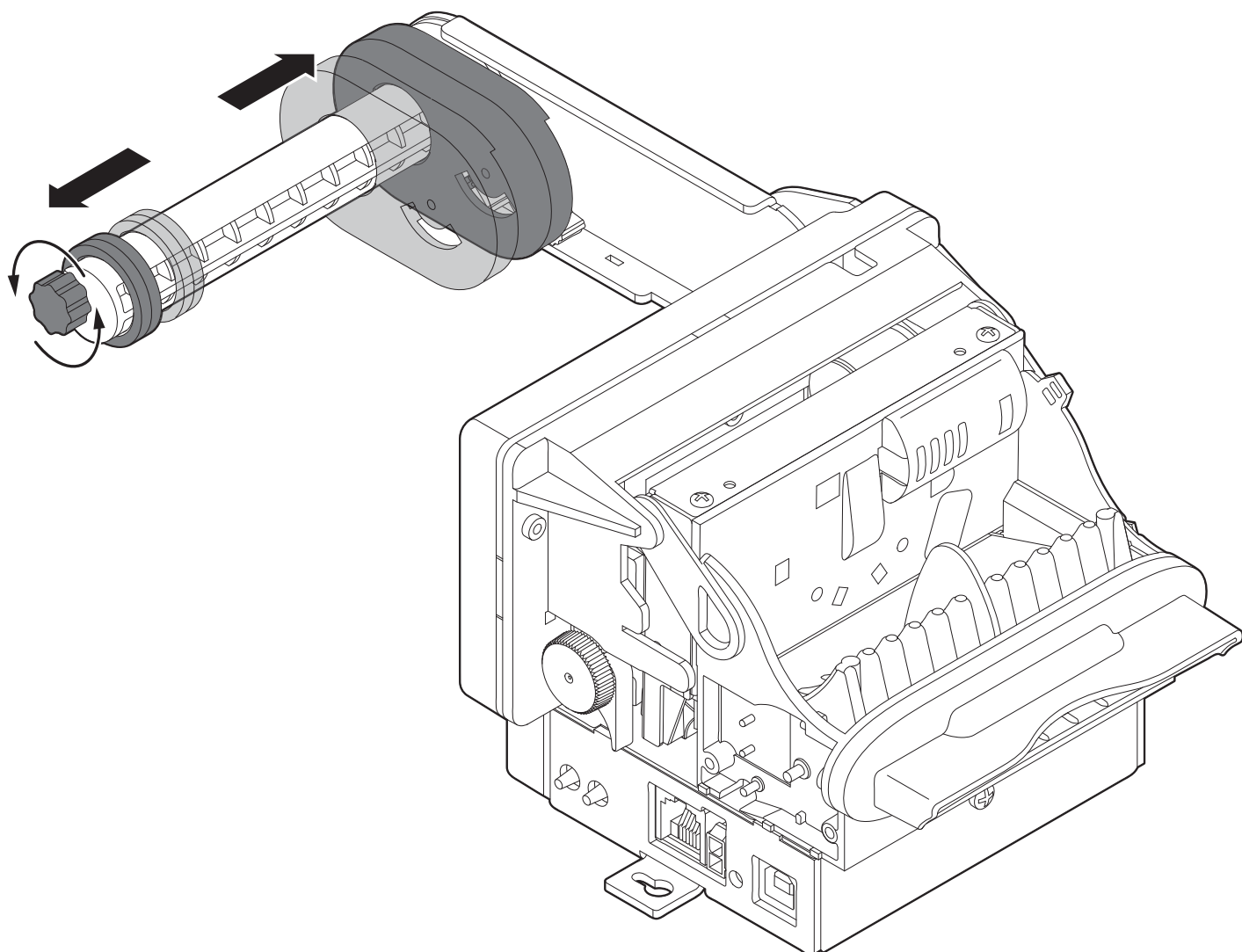

4.4 Adjusting paper stock

The device allows the move the position of the low paper sensor to adjust the amount of paper on the roll under which report the low paper.

Use the lever shown in figure to move the low paper sensor: move the lever up to increase the paper stock, move the lever down to decrease the paper stock.

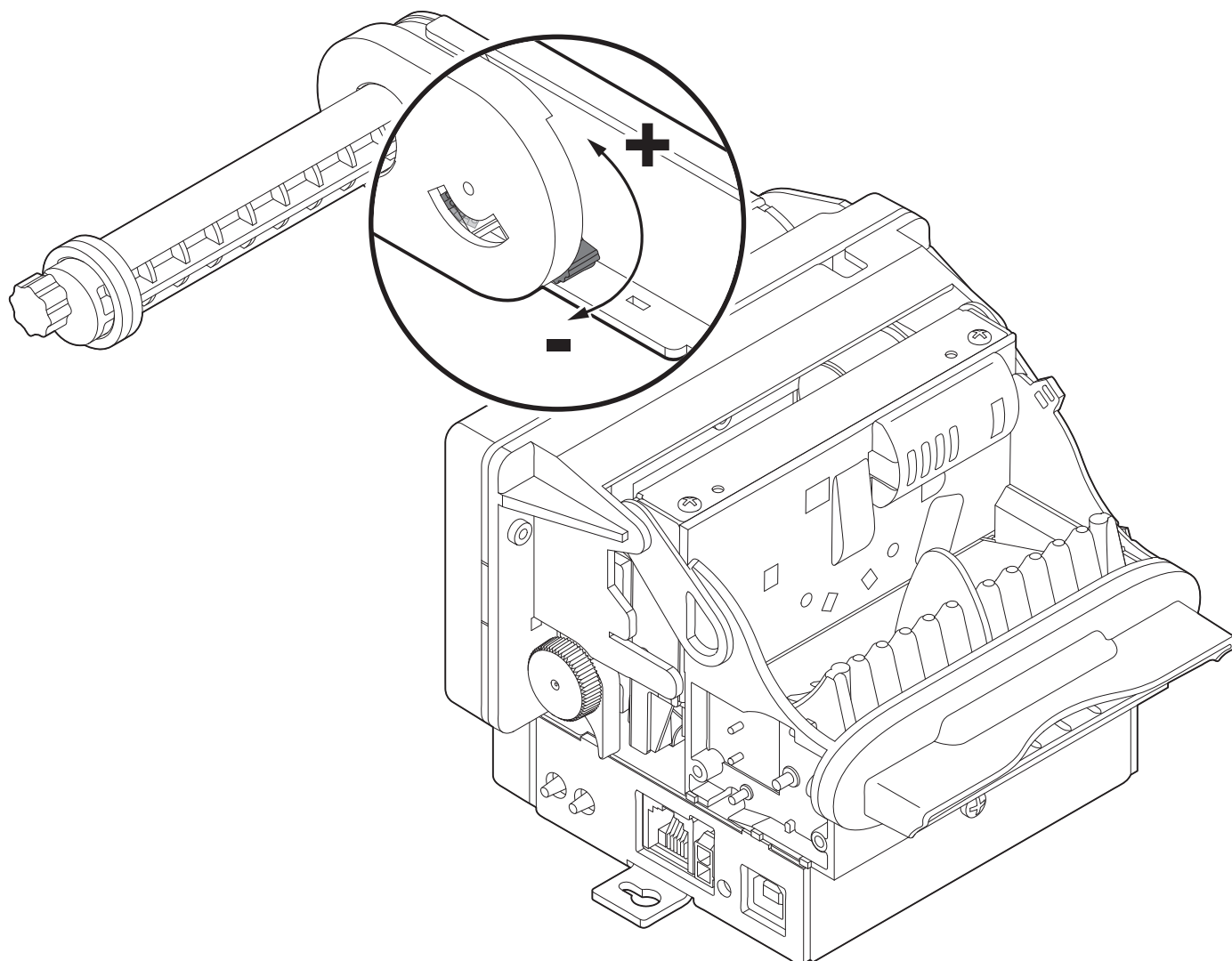



4.5 Switch the device on

1

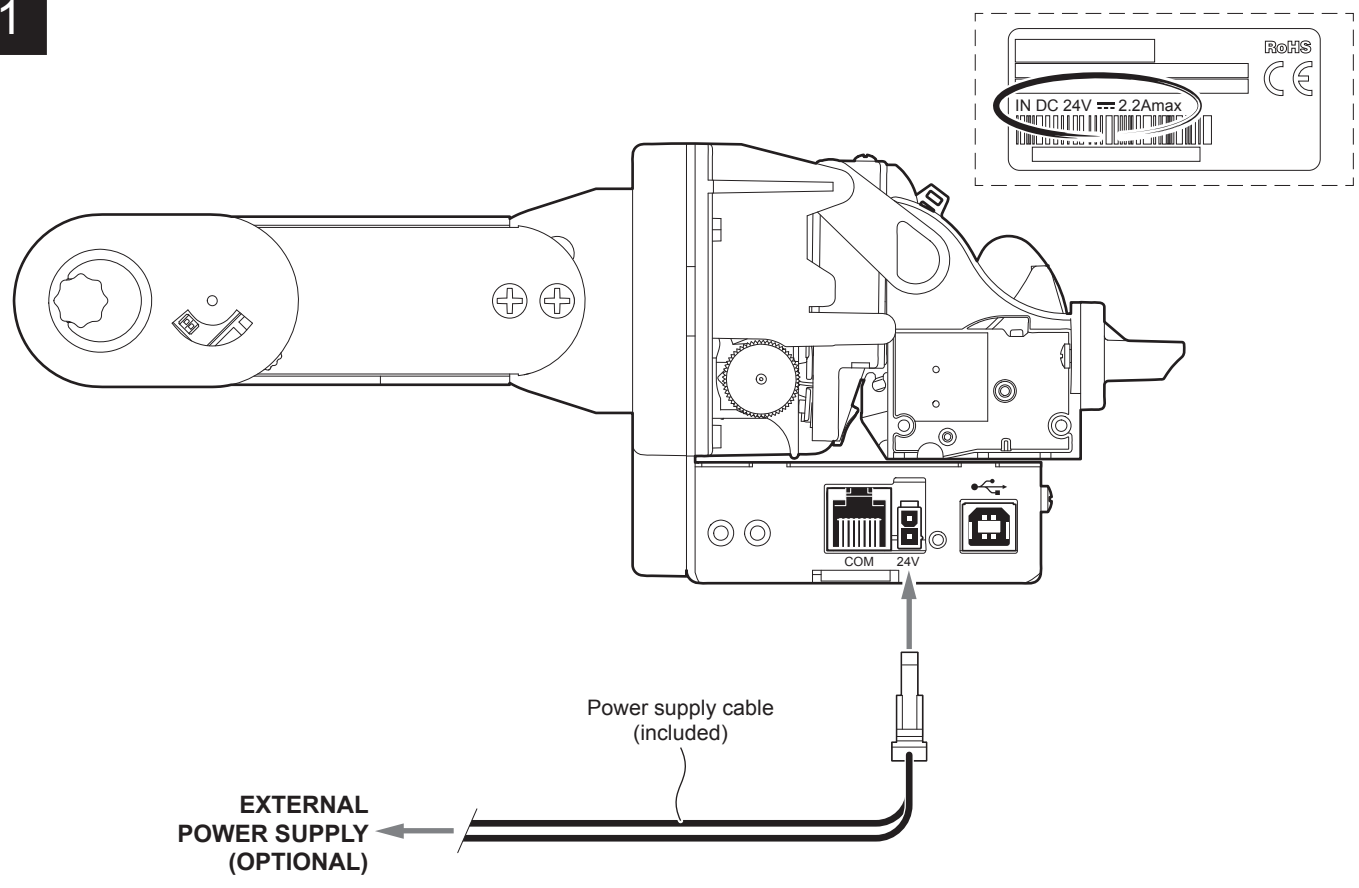

Connect the power supply cable to an external power supply unit and to the device.
Use the type of electrical power supply indicated on the label.

2

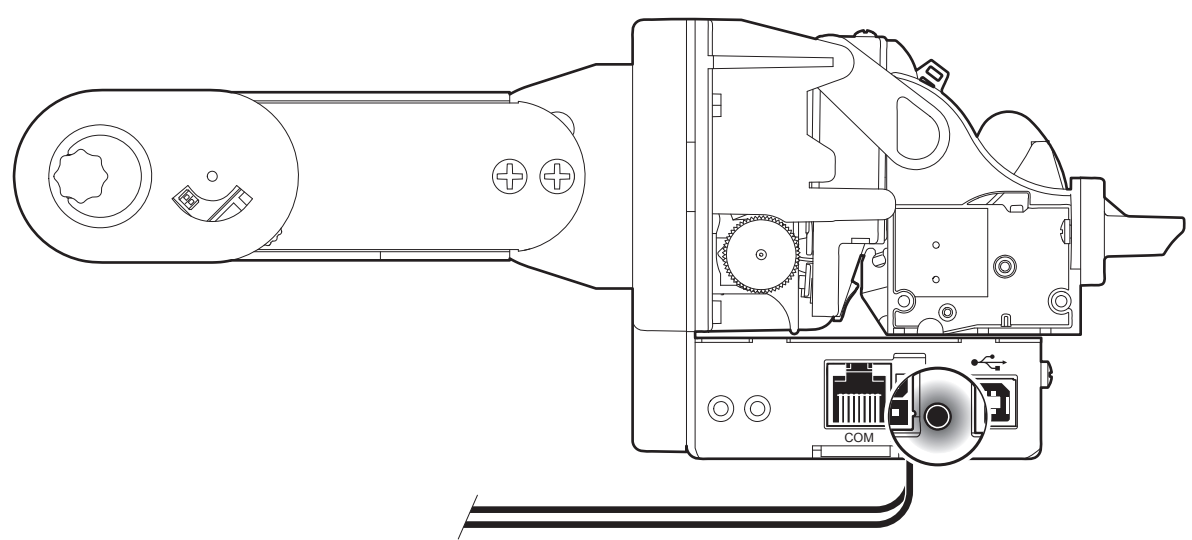

The green status LED turns on
and the device is ready.



4.6 Loading the paper roll

The device is equipped with an automatic paper roll loading system. It is not necessary to act directly on the printer to load the paper.

Use the service lever only in case of a paper jam (see [paragraph 7.1](#)).

Proceed as follows.

1

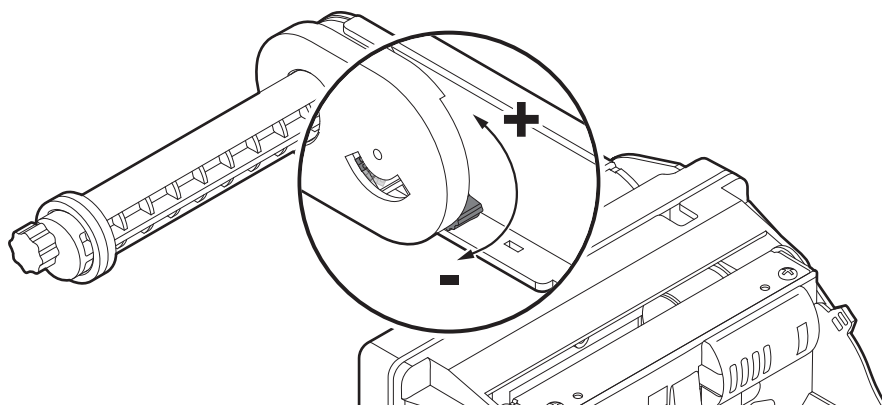

Adjust the paper stock
(see [paragraph 4.4](#)).

2

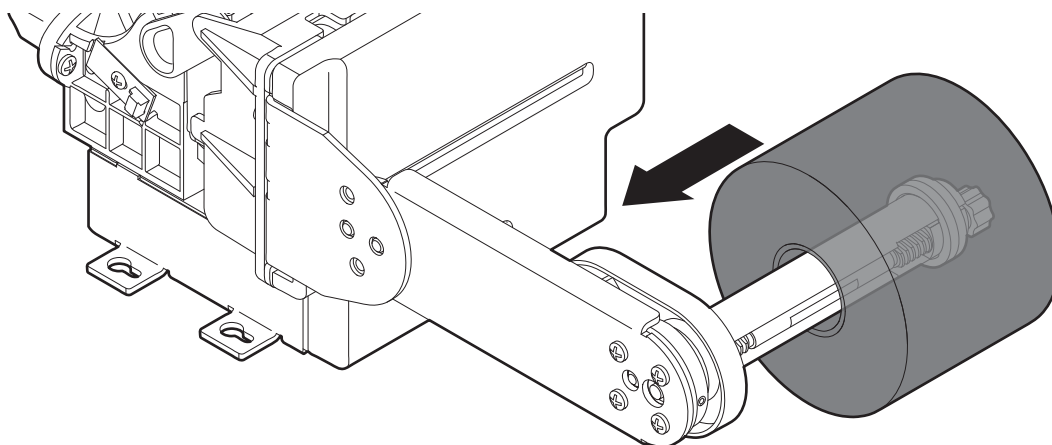

Insert the paper roll on the pin of the roll holder.

3

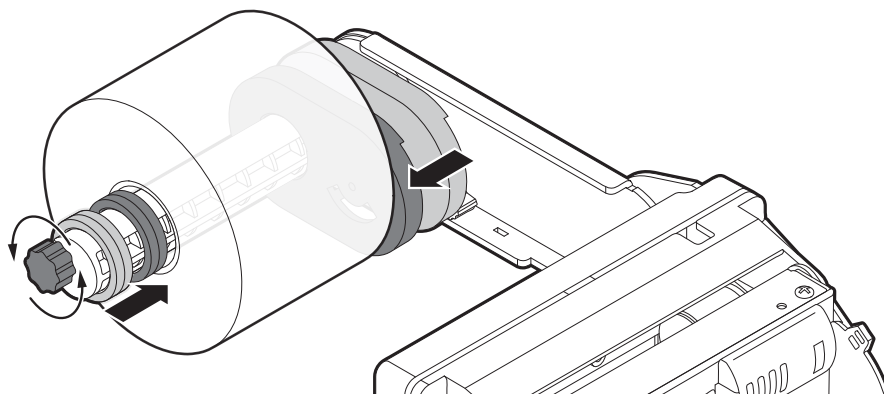

Adjust the paper width
(see [paragraph 4.3](#)).

4

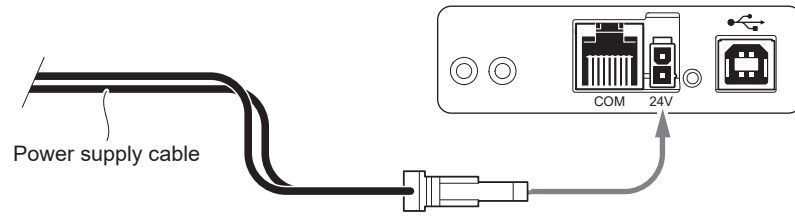

Switch on the device
(see [paragraph 4.5](#)).

5

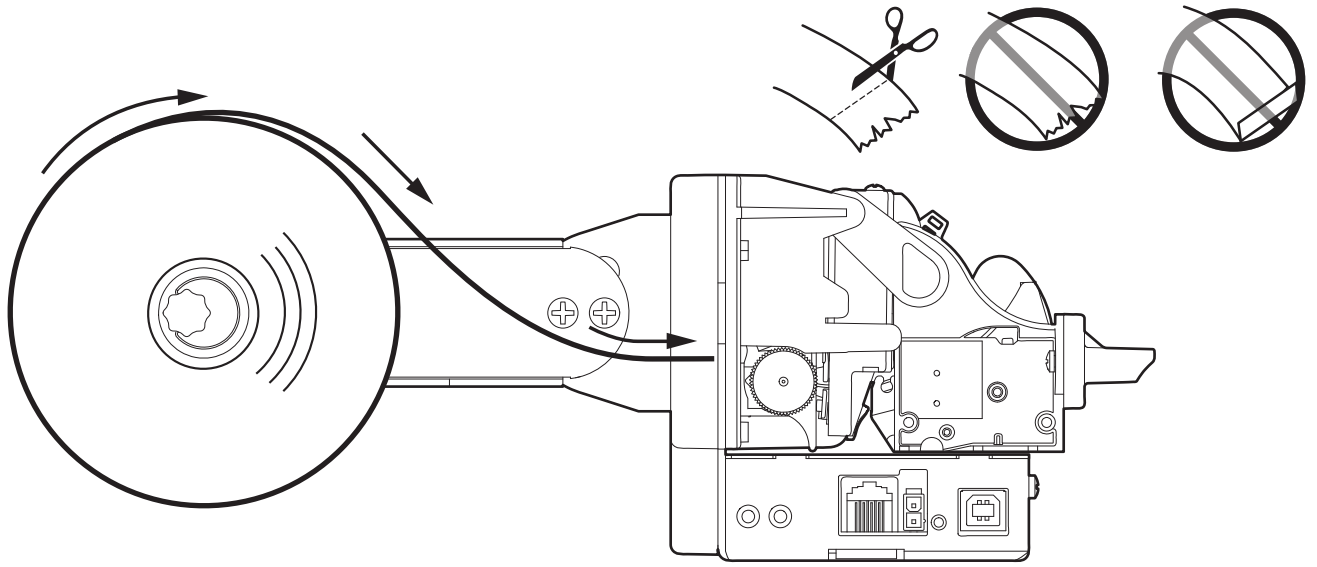

Insert the paper into the the input mouth
so that it unrolls correctly, as shown in figure.

6

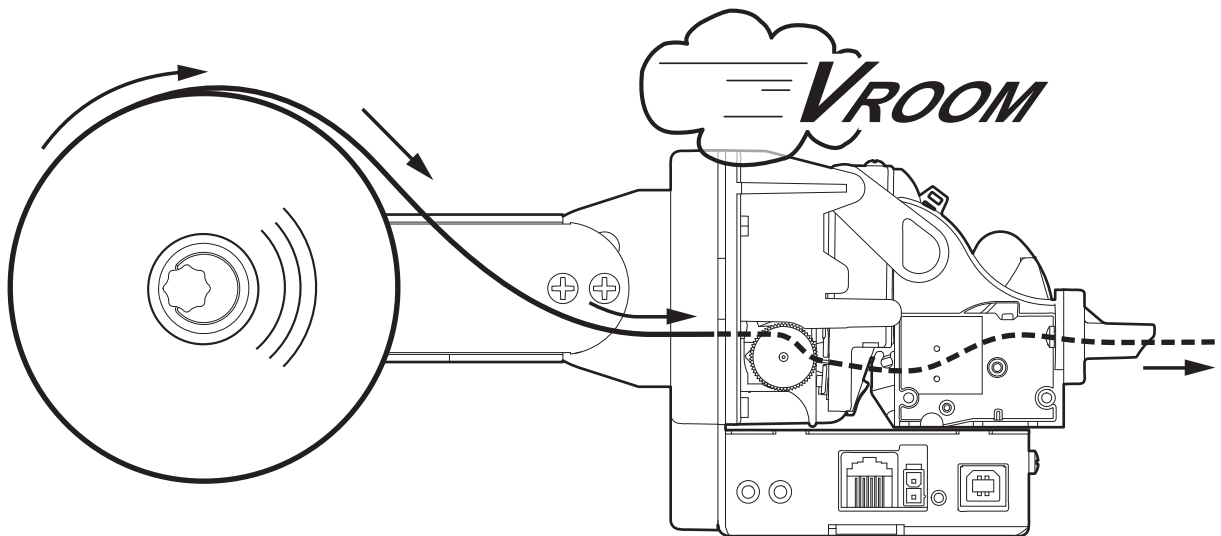

Wait until the paper is automatically loaded and cut.

4.7 Anti-jamming system

The withdrawal of the ticket before the end of printing, may damage the printing mechanism or the paper ripping resulting in probable jam.

The device is equipped with an anti-jamming system that starts operating when the user tries to pick up the ticket while printing is still in progress.

This system is composed of a tilting plane placed under the inspection door and of a fork sensor that detects the movements of the tilting plane.

The user that make a ticket withdrawal before the printing end, causes the tension of the paper resulting in the lowering of the tilting plane. This movement engages the fork sensor: printing is interrupted and the ticket is cut instantly.

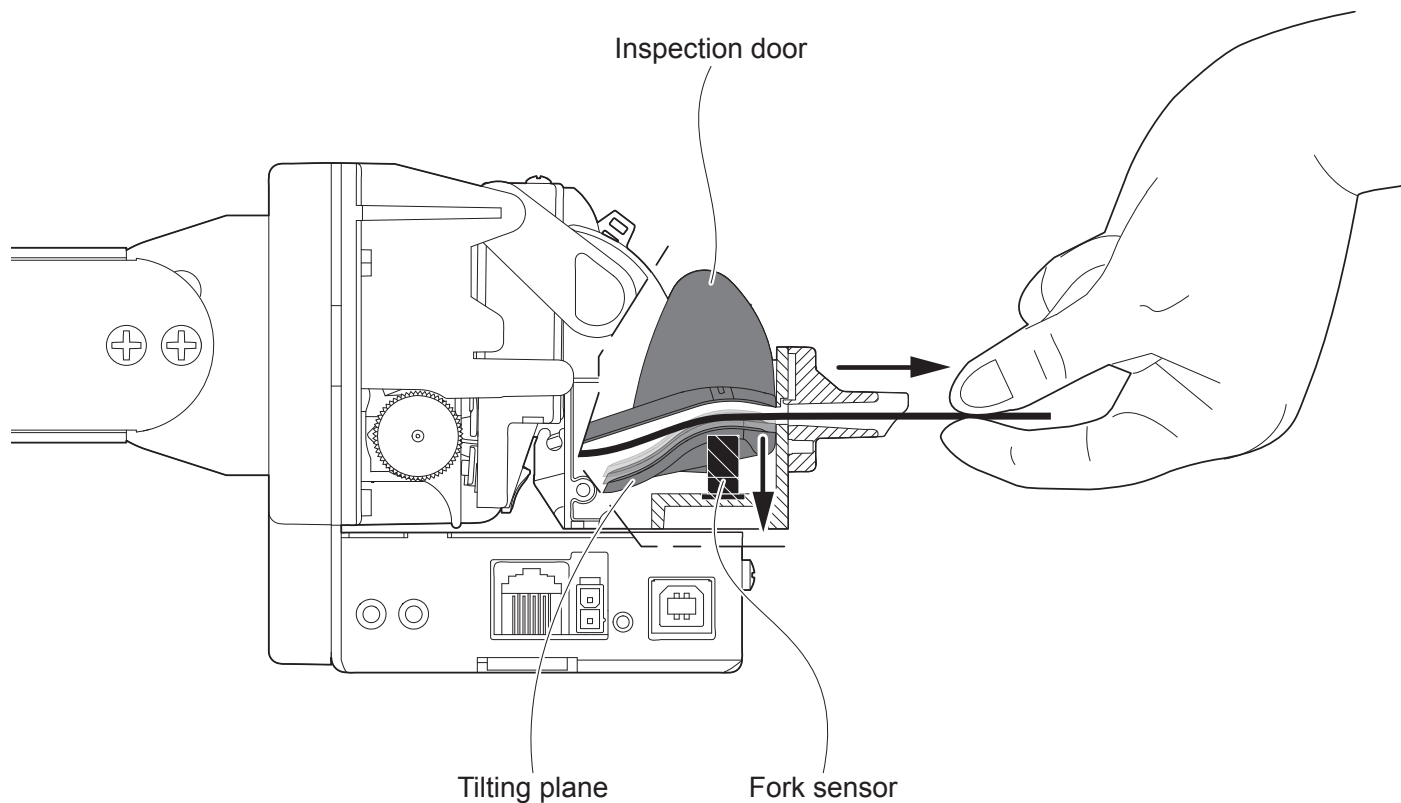

5 CONFIGURATION

5.1 Configuration by keys

To enter the configuration mode and print a setup report with the operating parameters of the device, proceed as follows.

1

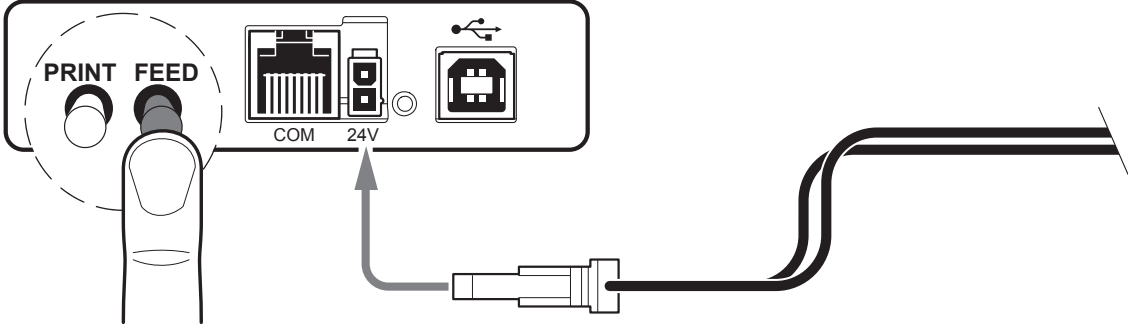

While pressing the FEED key, switch on the device by inserting the power supply cable.

2

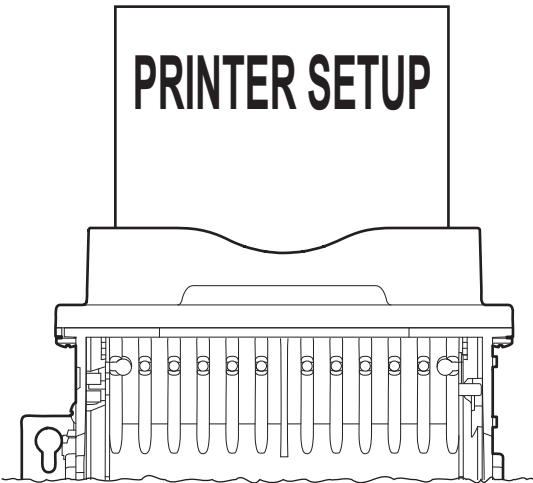

The device prints the report with parameters for settings.

3

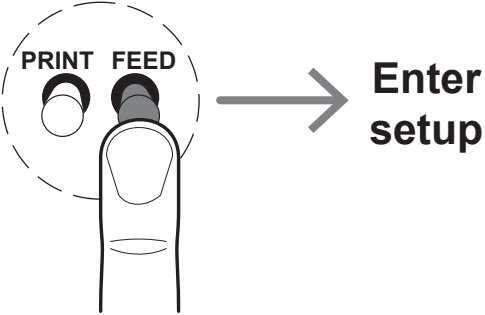

Press the FEED key to enter the configuration mode (see [paragraph 2.4](#)).



The following figure shows the setup report of the device. The shown values for parameters are sample values; for the list and the description of device parameters see the following paragraphs.

DEVICE NAME AND
FIRMWARE MODULES
RELEASE

```

                < device name >
SCODE: <code>      - rel 1.00
FCODE: <code>      - rel 1.00
LCODE: <code>      - rel 1.00
  
```

DEVICE
STATUS

PRINTER SETTINGS

```

PRINTER TYPE .....<device model>
INTERFACE .....RS232
PROGRAM MEMORY TEST.....OK
DYNAMIC RAM TEST.....OK
CUTTER TEST.....OK
HEAD VOLTAGE          [V] = 23.37
HEAD TEMPERATURE     [°C] = 25
POWER ON COUNTER      = 72
PAPER PRINTED         [cm] = 6220
CUT COUNTER           = 2218
LED bar FGND (RRGGBB) = 00FF00
LED bar BGND (RRGGBB) = 8F00FF
PWM BLACK MARK AVG.   = 35%
PWM BLACK MARK WHITE  = 12%
PWM BLACK MARK BLACK  = 59%
  
```

PARAMETERS
FOR DEVICE
CONFIGURATION

```

Printer Emulation ..... : TGH
RS232 Baud Rate ..... : 115200 bps
RS232 Data Length ..... : 8 bits/chr
RS232 Parity ..... : None
RS232 Handshaking ..... : Hardware
Busy Condition ..... : RxFull
Print Mode ..... : Normal
Autofeed ..... : CR Disabled
Code Table [num] ..... : 0
Chars / inch ..... : A=11 B=15 cpi
Font Type..... : International
Tear Auto Cut..... : Enabled
Speed / Quality..... : Normal
Print Width ..... : 76 mm
Paper Threshold ..... : 40%
Black Mark Position ..... : Disabled
Black Mark Threshold..... : 30%
Black Mark Sensor ..... : Internal
Black Mark Distance [mm]..... : +00.0
PaperEnd Buffer Clear ..... : Disabled
USB Address Number ..... : 0
USB Class ..... : Printer
Low Energy Mode ..... : Disabled
Pap.Jam Status Delay..... : Disabled
Print Density..... : 0%
  
```

KEYS FUNCTIONS

```

[ FEED ]      enter Printer setup
[ PRINT ]     skip Setup
  
```

5.2 Configuration by software

The setup parameters can be set by using the “PrinterSet” software tool available on www.custom4u.it. For a detailed description of the device operating parameters see the following paragraphs. To configure the device by software, proceed as follows:

1

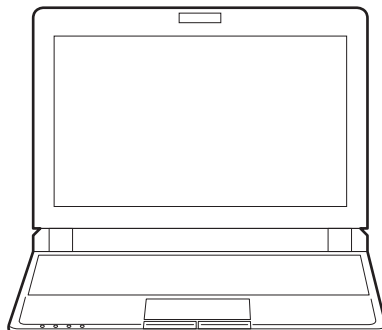

Connect the device to a PC directly (see [paragraph 3.3](#)), without using HUB devices.

2

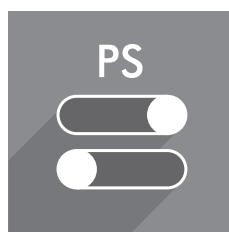

Start “PrinterSet” software tool.

3

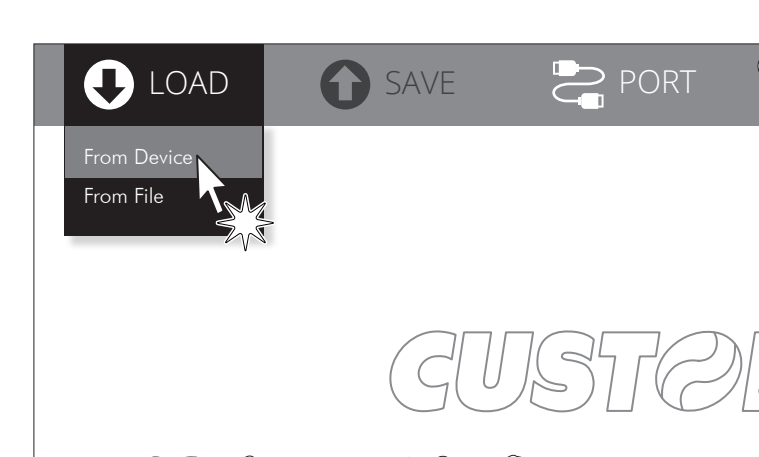

Click on LOAD > FROM DEVICE and select the device connected to the PC.

4

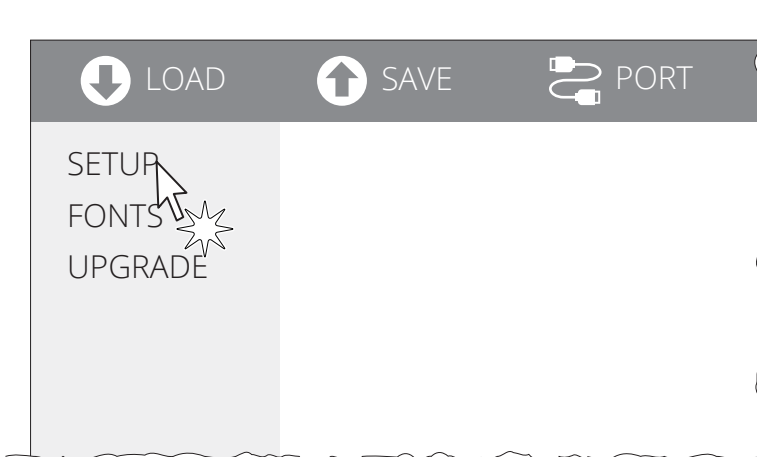

Click on SETUP to access the operating parameters of the device to be configured.

5

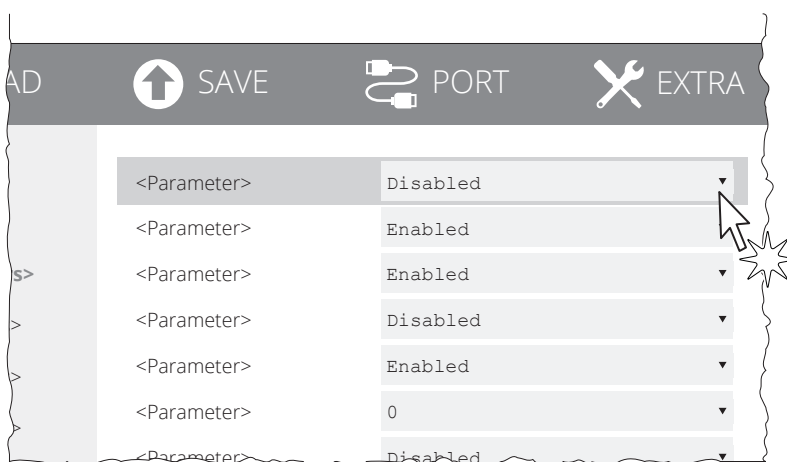

Make the desired changes to the device operating parameters.

6

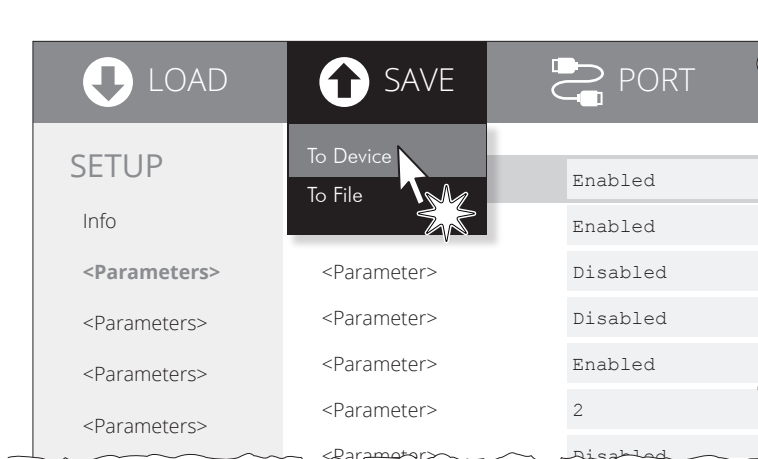

Click on SAVE > TO DEVICE to make the changes made effective.

ATTENTION:

During saving, it is strongly discouraged to disconnect the communication cable or to remove the power supply of the PC or the device.



5.3 Device status

The device operating status is indicated in the configuration print-out in which, next to the name of the components displayed, the following information is given:

PRINTER TYPE	device model
INTERFACE	interface present
PROGRAM MEMORY TEST	OK appears if functioning and NOT OK if faulty
DYNAMIC RAM TEST	OK appears if functioning and NOT OK if faulty
CUTTER TEST	OK appears if functioning and NOT OK if faulty
HEAD VOLTAGE	voltage of the head
HEAD TEMPERATURE	temperature of the head
POWER ON COUNTER	number of power-ups made
PAPER PRINTED	centimetres of paper printed
CUT COUNTER	number of cuts made
LED bar FGND (RRGGBB)	foreground colour set for the status LED on the bezel
LED bar BGND (RRGGBB)	background colour set for the status LED on the bezel
PWM BLACK MARK AVG.	average value of the PWM of the alignment sensor
PWM BLACK MARK WHITE	value of the PWM for the white color of the alignment sensor
PWM BLACK MARK BLACK	value of the PWM for the black color of the alignment sensor



5.4 Communication parameters

The device allows the configuration of the parameters listed in the following table.

The parameters marked with the symbol [Ⓓ] are the default values.

Settings remain active even after the device has been turned off and they are stored in non-volatile memory.

RS232 BAUD RATE	Communication speed of the serial interface: 9600 57600 19200 115200 [Ⓓ] 38400 This parameter is valid only with serial interface.
RS232 DATA LENGTH	Number of bit used for characters encoding: 7 bits/car 8 bits/car [Ⓓ] This parameter is valid only with serial interface.
RS232 PARITY	Bit for the parity control of the serial interface: None [Ⓓ] = parity bit omitted Even = even value for parity bit Odd = odd value for parity bit This parameter is valid only with serial interface.
RS232 HANDSHAKING	Handshaking: XON/XOFF = software handshaking Hardware [Ⓓ] = hardware handshaking (CTS/RTS) This parameter is valid only with serial interface. When the receive buffer is full, if handshaking is set to XON/XOFF, the device sends the XOFF (0x13) on the serial port. When the receive buffer has cleared once again, if handshaking is set to XON/XOFF, the device sends the XON (0x11) on the serial port.
BUSY CONDITION	Activation mode for Busy signal: OffLine/ RXFull = Busy signal is activated when the device is both in OffLine status and the buffer is full RXFull [Ⓓ] = Busy signal is activated when the buffer is full This parameter is valid only with serial interface.
USB ADDRESS NUMBER	Numerical address code for the univocal identification of the USB device (in case of more than a USB device connected with the same PC): 0 [Ⓓ] 2 4 6 8 1 3 5 7 9



USB CLASS

USB communication class definition.

Printer ^D = setting the printer functionVirtual COM = setting the USB port as a virtual serial port



5.5 Operating parameters

The device allows the configuration of the parameters listed in the following table.

The parameters marked with the symbol ^D are the default values.

Settings remain active even after the device has been turned off and they are stored in non-volatile memory.

PRINTER EMULATION	Available emulations for the device: TGH ^D CUSTOM/POS
--------------------------	--

PRINT MODE	Printing mode: Normal ^D = enables printing in normal writing way Reverse = enables printing rotated 180 degrees
-------------------	--

AUTOFEED	Setting of the Carriage Return character: CR disabled ^D = Carriage Return disabled CR enabled = Carriage Return enabled
-----------------	--

CHARS / INCH	Font selection: A = 11 cpi, B = 15 cpi ^D A = 15 cpi, B = 20 cpi A = 20 cpi, B = 25 cpi CPI = Characters Per Inch.
---------------------	--

FONT TYPE	Setting of the font type: International ^D = Enables the use of the 256 characters font tables Chinese GB18030 = Enables the use of the chinese extended font GB18030-2000 Korean CP949 = Enables the use of the korean font CP949 When the “International” font is enabled, you need to choose the character code table (parameter “Code Table”). When the Chinese font is enabled, the selection of the character code table is suspended (parameter “Code Table”).
------------------	---

CODE TABLE	Identifier number of the character code table to use. See paragraph 8.6 to learn about the character tables corresponding to the identification numbers set with this parameter. The character tables set with this parameter are the same set with the command 0x1B 0x74 (refer to the commands manual of the device).
-------------------	---

TEAR AUTO CUT	Management of autocut function: Disabled Enabled ^D
----------------------	---



SPEED / QUALITY	Setting of printing speed and printing quality: Normal ^D High Speed
------------------------	--

PRINT WIDTH	Width of printing area: 52 mm 64 mm 76 mm ^D 56 mm 68 mm 80 mm 60 mm 72 mm
--------------------	--

PAPER THRESHOLD	Threshold value (in percent) for the recognition of the presence of paper by the paper presence sensor: 30% 60% 90% 40% ^D 70% 50% 80%
------------------------	--

PAPEREND BUFFER CLEAR	Cleaning mode of the data in receive buffer, if the printing is stopped due to lack of paper: Disabled ^D = the data remain in the receive buffer. When the paper runs out, the device keeps the remaining data in the receive buffer and prints the remaining portion of the ticket after that the new paper is loaded. Enabled = when the paper runs out, all data in the receive buffer are deleted.
------------------------------	---

LOW ENERGY MODE	Setting the inactivity period in seconds after which the device enters in low energy mode: Disabled ^D 15 s 30 s 60 s
------------------------	---

PAPER JAM STATUS DELAY	Setting the delay, expressed in seconds, in a paper jam detecting: Disabled ^D 2 s 1 s 3 s
-------------------------------	---

LED bar FGND (RRGGBB)	Set the foreground color for the status LED on the bezel. This parameter consists in three value for red, green and blue color to be expressed in hexadecimal: RR = from 00 ^D to FF GG = from 00 to FF ^D BB = from 00 ^D to FF
------------------------------	---

LED bar BGND (RRGGBB)	Set the background color for the status LED on the bezel. This parameter consists in three value for red, green and blue color to be expressed in hexadecimal: RR = from 00 to FF (8F ^D) GG = from 00 ^D to F BB = from 00 to FF ^D
------------------------------	--



PRINT DENSITY

Adjusting the printing density:

-25% 0^D +25%
-12% +12%

The print quality is strongly influenced by the type of chemical treatment and the type of storage to which the thermal paper has been subjected, as well as by the weight of the same. It may therefore necessary to act on this parameter to obtain the desired print quality.



5.6 Alignment parameters

This printer allows the configuration of the parameters listed in the following table.

The parameters marked with the symbol ^D are the default values.

Settings remain active even after the printer has been turned off and they are stored in non-volatile memory.

BLACK MARK POSITION	Management of the paper alignment: Disabled ^D = the black mark alignment is not performed Enabled = the black mark alignment is performed																																																
BLACK MARK SENSOR	Choice of the black mark alignment sensor: Internal ^D = the black mark position is detected by the printing mechanism sensor Eternal = the black mark position is detected by the paper input sensor																																																
BLACK MARK THRESHOLD	Threshold value (in percent) for the recognition of the presence of black mark by the black mark sensor: 30% ^D 70% 40% 80% 50% 90% 60%																																																
BLACK MARK DISTANCE	<p>“Black Mark Distance” is the minimum distance (in millimetres) between the upper edge of ticket and the black mark (see chapter 6).</p> <p>The numeric value of the distance is made up with the following four parameters for the setting of three digits (two for the integer part of the number and one for the decimal part) and of the sign:</p> <table border="1"> <tr> <td></td> <td colspan="5">Sign setting:</td> </tr> <tr> <td>BLACK MARK DISTANCE SIGN</td> <td colspan="5">+ ^D = positive distance - = negative distance</td> </tr> <tr> <td></td> <td colspan="5">Setting the digit for tens:</td> </tr> <tr> <td>BLACK MARK DISTANCE [mm x 10]</td> <td>0 ^D</td> <td>2</td> <td>4</td> <td>6</td> <td>8</td> </tr> <tr> <td></td> <td>1</td> <td>3</td> <td>5</td> <td>7</td> <td>9</td> </tr> <tr> <td></td> <td colspan="5">Setting the digit for units:</td> </tr> <tr> <td>BLACK MARK DISTANCE [mm x 1]</td> <td>0 ^D</td> <td>2</td> <td>4</td> <td>6</td> <td>8</td> </tr> <tr> <td></td> <td>1</td> <td>3</td> <td>5</td> <td>7</td> <td>9</td> </tr> </table>		Sign setting:					BLACK MARK DISTANCE SIGN	+ ^D = positive distance - = negative distance						Setting the digit for tens:					BLACK MARK DISTANCE [mm x 10]	0 ^D	2	4	6	8		1	3	5	7	9		Setting the digit for units:					BLACK MARK DISTANCE [mm x 1]	0 ^D	2	4	6	8		1	3	5	7	9
	Sign setting:																																																
BLACK MARK DISTANCE SIGN	+ ^D = positive distance - = negative distance																																																
	Setting the digit for tens:																																																
BLACK MARK DISTANCE [mm x 10]	0 ^D	2	4	6	8																																												
	1	3	5	7	9																																												
	Setting the digit for units:																																																
BLACK MARK DISTANCE [mm x 1]	0 ^D	2	4	6	8																																												
	1	3	5	7	9																																												



Setting the digit for decimals:

BLACK MARK DISTANCE [mm x 0.1]	0 ^D	2	4	6	8
	1	3	5	7	9

NOTE:

For example, to set the black mark distance to 15 mm, modify the parameters as follows:

Black Mark Distance Sign = +
Black Mark Distance [mm x 10] = 1
Black Mark Distance [mm x 1] = 5
Black Mark Distance [mm x .1] = 0



5.7 Hexadecimal dump

This function is used for the diagnosis of the characters received from the communications port. Characters are printed as hexadecimal code and the corresponding ASCII code (see below). Each line is preceded by a counter in hexadecimal that indicates the number of bytes received.

During the startup, if you hold down the FEED key, the printer enters the self-test routine and print the setup report. The printer remains in standby until a key is pressed or characters are received through the communication port (Hexadecimal Dump mode). For each character sent, the ticket shows the hexadecimal value and the ASCII codes (if the characters are underlined, the receive buffer is full). Shown below is an example of a Hexadecimal Dump:

```

                                HEXADECIMAL DUMP

31 32 33 34 35 ...      12345 ...
39 30 31 32 33 ...      90123 ...
37 38 39 75 69 ...      789ui ...
68 6B 6A 73 64 ...      hkjsd ...
73 64 66 6B 6A ...      sdfkj ...
66 73 64 66 6B ...      fsdfk ...
65 69 6F 79 75 ...      eioyu ...
6F 72 69 75 77 ...      oriuw ...
6F 75 77 65 72 ...      ouwer ...
77 65 72 69 6F ...      werio ...
72 69 6F 75 77 ...      riouw ...
6B 6C 73 64 66 ...      klsdf ...
64 66 6B 73 64 ...      dfksd ...
73 64 66 6B 6A ...      sdfkj ...
66 6B F2 6A 73 ...      fk≥j ...
6A 6B 6C 68              jklh
```





6 ALIGNMENT

The device is provided with a sensor for the use of alignment black mark in order to handle rolls of tickets with pre-printed fields and a fixed length.

The alignment sensor is a “reflection” sensor: this kind of sensor emits a band of light and detects the quantity of light reflected to it. The presence of the black mark is therefore detected by the amount of light that returns to the sensor, considering that the light is reflected by the white paper and absorbed by the black mark.

To ensure the correct alignment, you must enable the “Black Mark Position” parameter during the setup procedure (see [paragraph 5.6](#)).

The following paragraphs show how to correctly set the configuration parameters of device in order to assure the alignment.

6.1 Calibration

The sensor calibration occurs automatically and consists in adjusting the quantity of light emitted to match the degree of whiteness of the paper used and the degree of black of the mark printed on paper.

The device automatically performs the self-calibration during the Setup procedure only if the “Black Mark Position” parameter is set to a value other than “Disabled” (see [paragraph 5.6](#)).

When self-calibration starts, the device performs some paper feeds and then it prints the calibration result and the value of the PWM duty-cycle of the alignment sensor driver so that it can be perform an optimal black mark detection:

Autosetting Black Mark: OK
 PWM Duty Cycle: 85.3%

The “Autosetting Black Mark” parameter indicates the result of the self-calibration procedure; OK will appear if it has been successful, NOT OK will appear if the procedure has failed.

After the printing of the procedure result, the device offers the execution of the function of paper characterization “Characterize Paper” and the change of the “Black Mark Threshold” parameter which represents the detection threshold of the black mark.

Choosing the “Yes” value for the “Characterize Paper” parameter, the device prints a graphic representation (see following figures) of the outgoing voltage of the alignment sensor (expressed as a percentage) and the “Black Mark Threshold” value. This graphic representation is useful to set the most suitable value to assign to the “Black Mark Threshold” parameter and then to better identify the optimal threshold value which takes into account the variations of the signal and the small oscillations around zero.

The following figure shows an example of paper with the non-thermal paper printed with black marks: the outgoing voltage is constant while passing the white paper between two black marks and presents a peak at each black mark. In this case, the optimal value for the “Black Mark Threshold” parameter is placed about half of the peak.

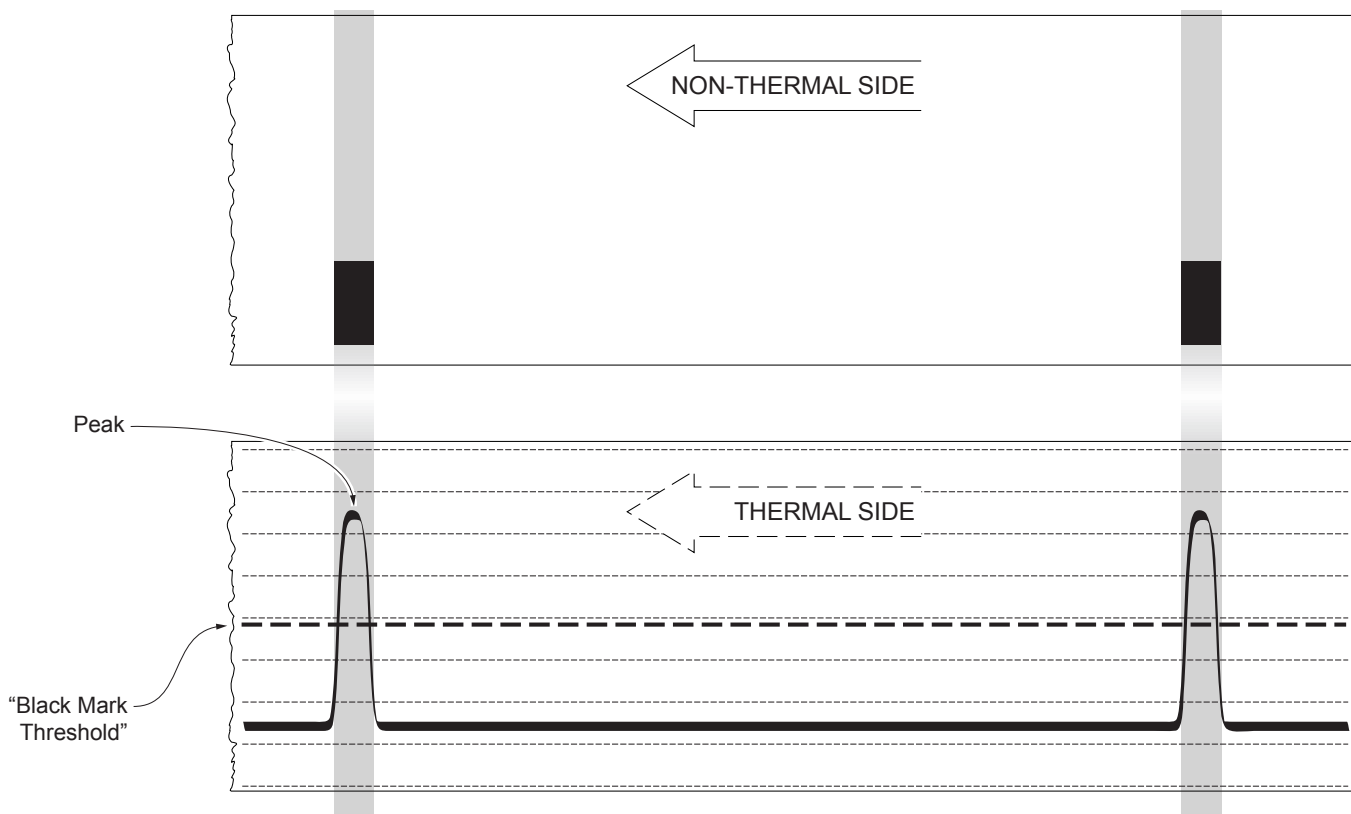

The following figure shows an example of paper with the non-thermal paper printed with black marks and other graphics (for example, a barcode): the outgoing voltage is constant while passing the white paper between two black marks, presents a peak at each black mark and presents some “noise” at each barcode. In this case, the optimal value for the “Black Mark Threshold” parameter is located about halfway between the peak value and the maximum value of the “noise”.

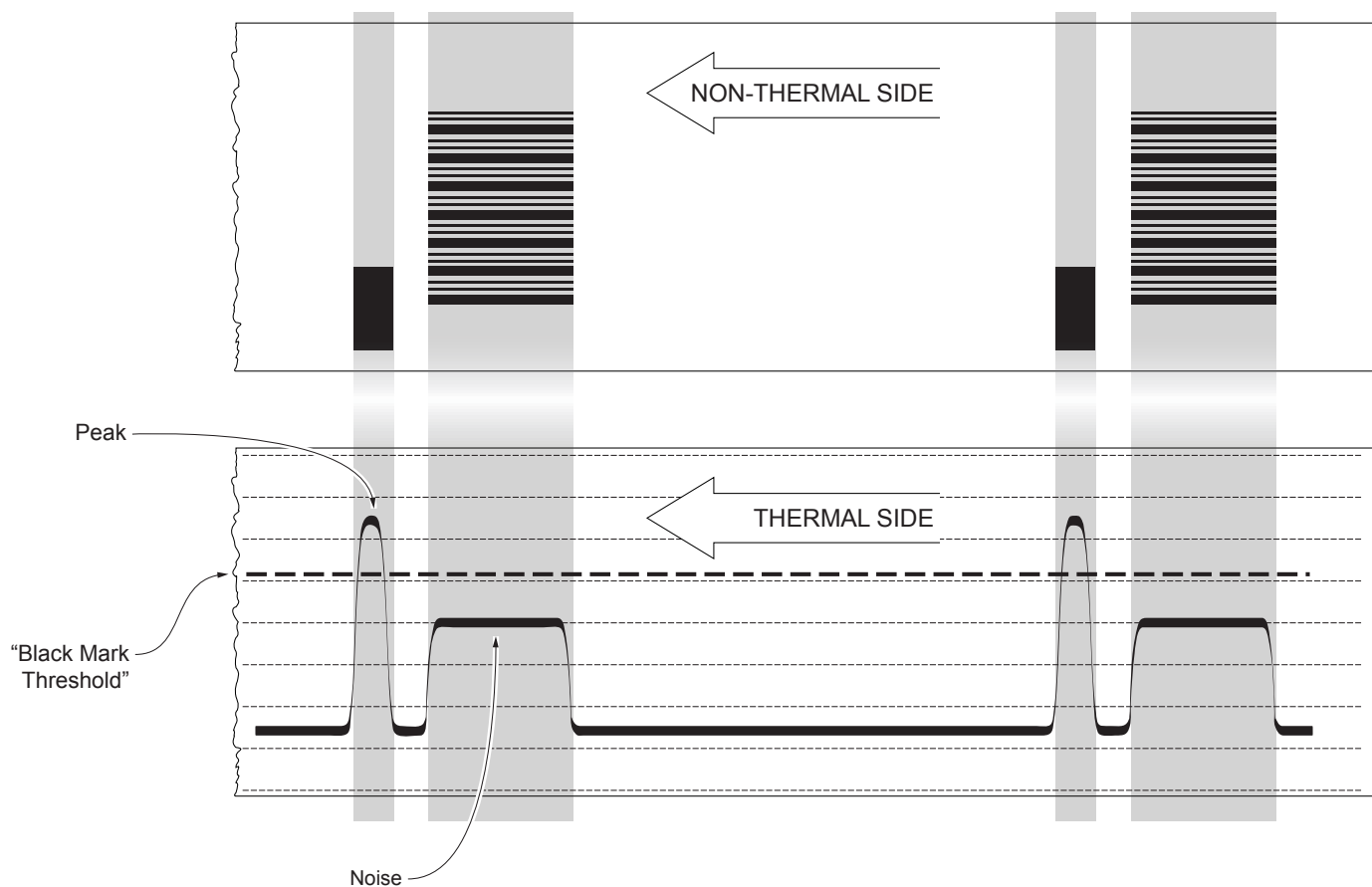

If the maximum value of “noise” read by the sensor is very close to the peak value, it might be difficult to place the value of the “Black Mark Threshold” at an intermediate point. In these cases, it is mandatory that the portion of paper between the point of printing end and the front black mark is completely white (no graphics). In this way, the only next graphic detected by the sensor for alignment after the printing end will be the black mark.

6.2 Alignment parameters

The “alignment point” is defined as the position inside the ticket to use for the black mark alignment. The distance between the black mark edge and the alignment point is defined as “Black Mark Distance”.

Referring to the front of the black mark, the value of “Black Mark Distance” varies from -19.9 mm minimum and +99.9 mm maximum.

If the “Black Mark Distance” value is set to 0, the alignment point is set at the beginning of the black mark.

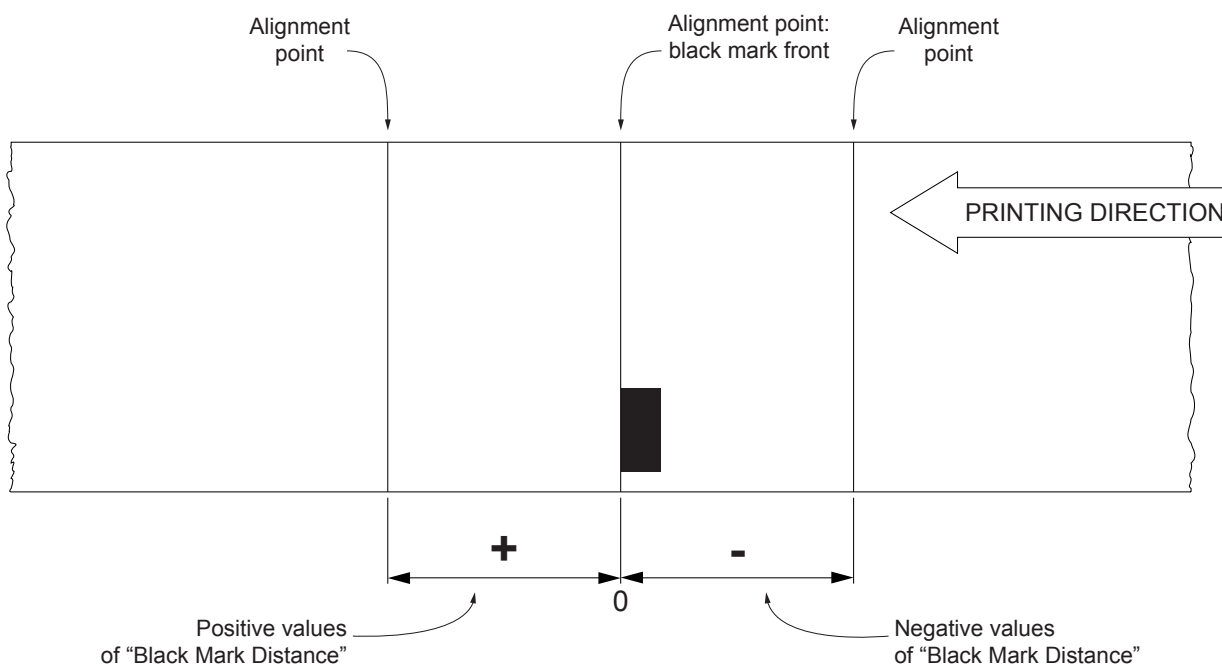

The following figure shows an example of paper with alignment point set by a positive value of “Black Mark Distance” (“Black Mark Distance” = + A):

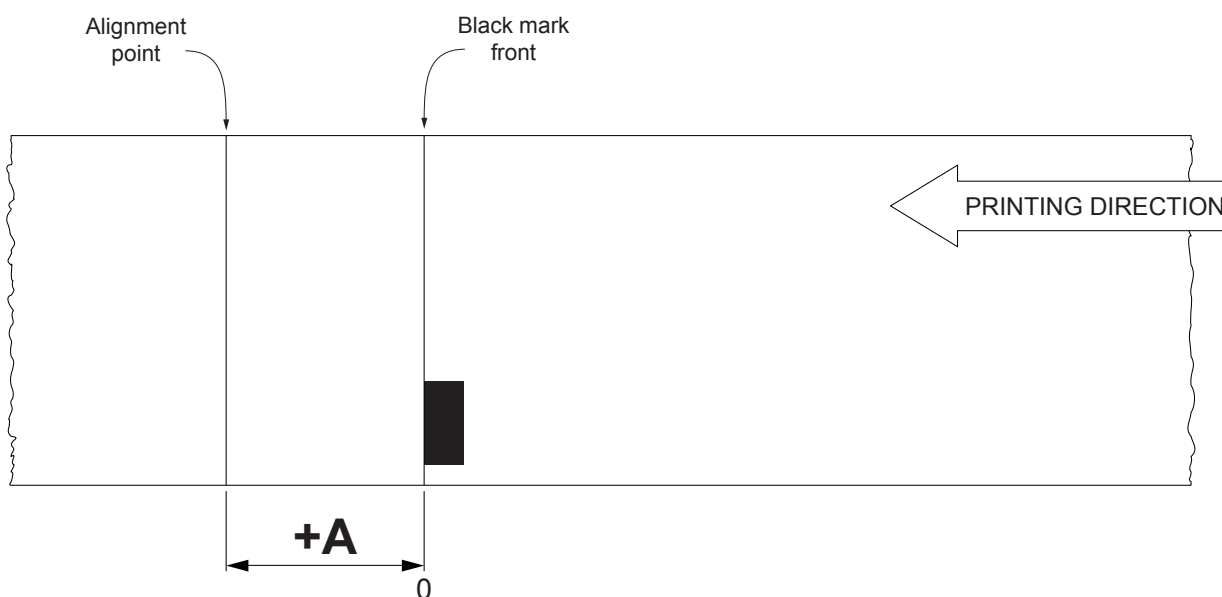

To set a negative value of the “Black Mark Distance” parameter is useful in cases where the alignment point refers to the black mark printed on the previous ticket or where the desired cutting line is placed in the middle of the alignment black mark. In the following images, the value of “Black Mark Distance” parameter is set to $-A$.

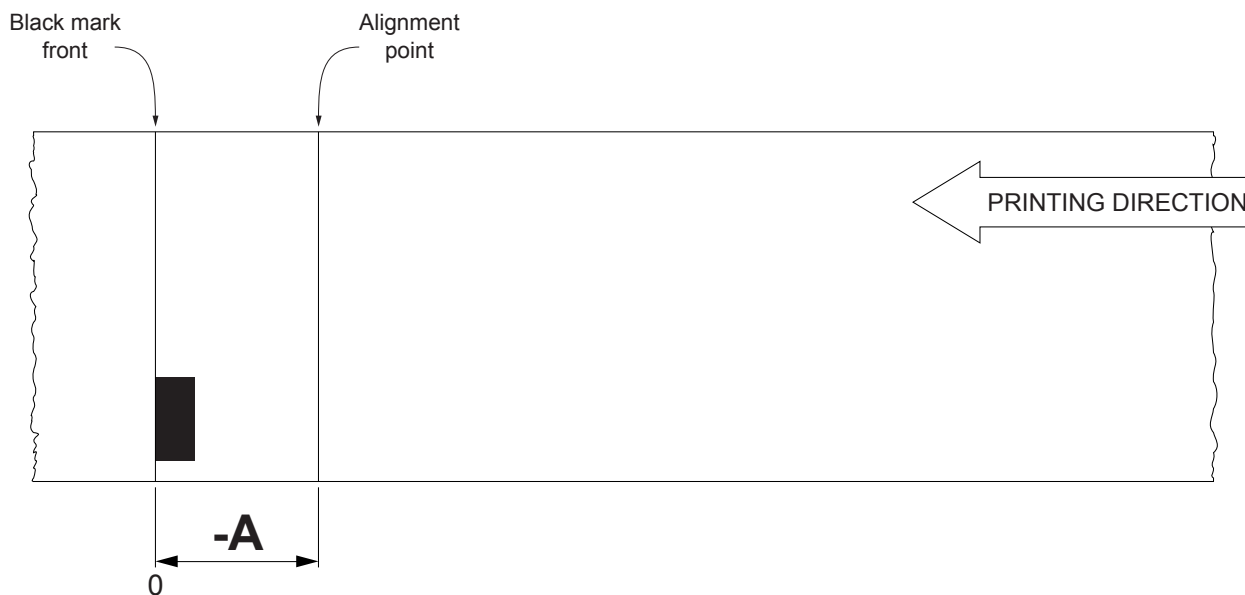

The following figure shows a section of the device with the paper path and the distances between the alignment sensor, the printing head and the autocutter (cutting line), where:

A = distance between the alignment sensor and the printing line = 12 mm

B = distance between the printing line and the cutting line = 12.5 mm

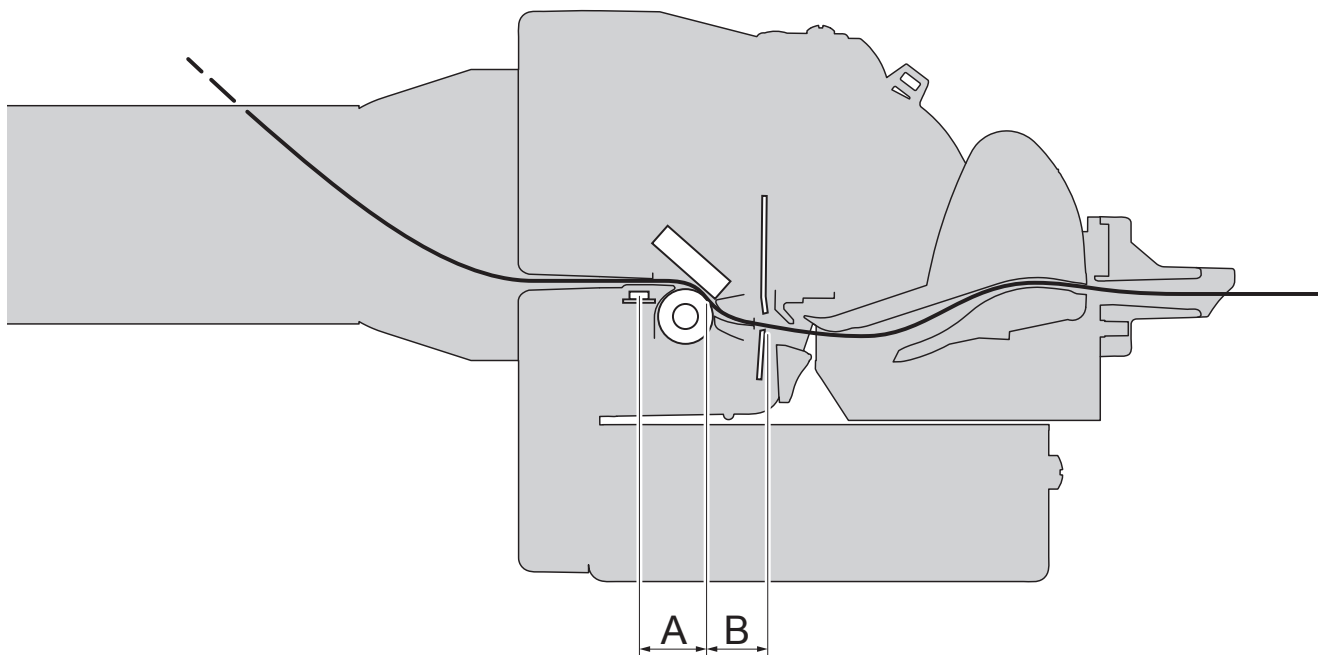



To define the alignment point you need to set the printer parameters that compose the numerical value of the “Black Mark Distance” parameter. (see [paragraph 5.6](#)).

For example, to set a black mark distance of 15 mm between the black mark and the alignment point, the parameters must be set on the following values:

Black Mark Distance sign	: +
Black Mark Distance [mm x 10]	: 1
Black Mark Distance [mm x 1]	: 5
Black Mark Distance [mm x .1]	: 0

The “Black Mark Distance” parameter, may be modified as described in [chapter 5](#).

6.3 Printing area

In order to print ticket containing only one black mark and to not overlay printing to a black mark (that will make it useless for the next alignment), it is important to well calibrate the length of the printing area of ticket according to the inter-black mark distance.

The following figure shows an example of tickets with “Black Mark Distance” set to 0:

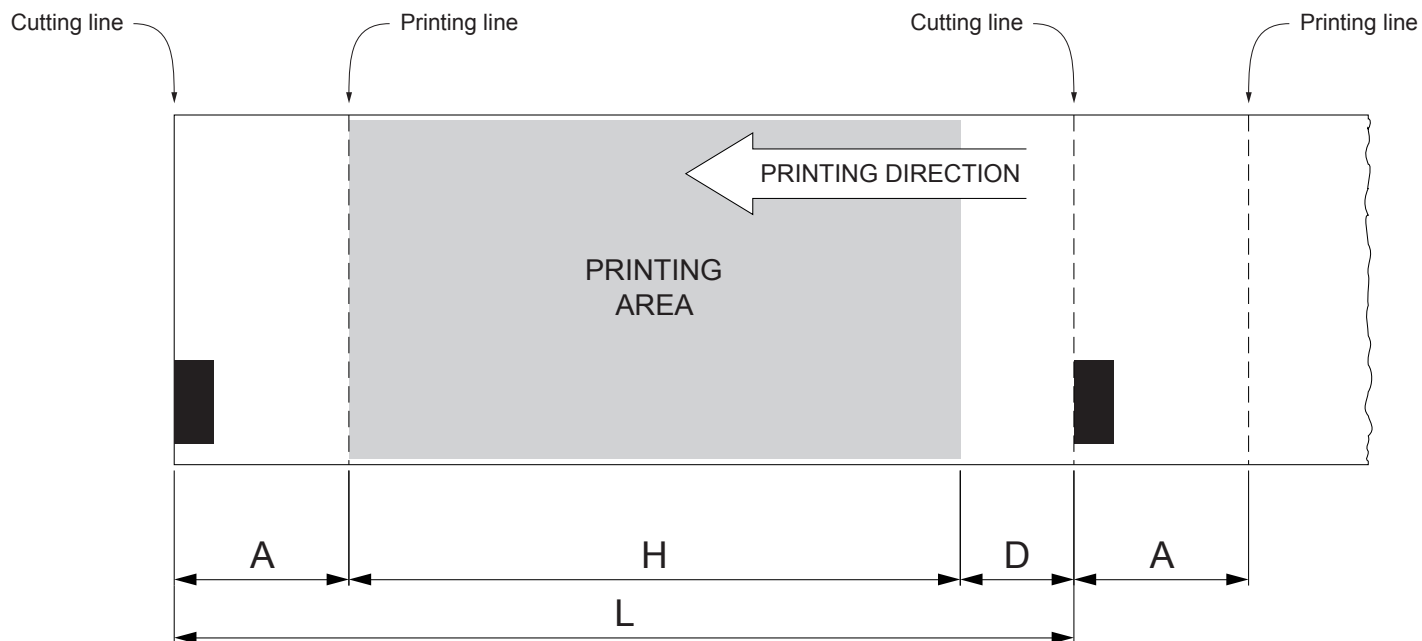

- A “Non-printable area” = “Distance between autocutter/printing head”
- H Distance between the first and the last print line, called “Height of the printing area”.
- L Distance between an edge of the black mark and the next one, called “Inter-black mark distance”.
- D Automatic feed for alignment at the next black mark.

To use all the black marks on the paper, you must comply with the following equation:

$$H + A \leq L$$

The height of the printing area H can be increased to make no progress on alignment D but no further.



7 MAINTENANCE

7.1 Paper jam

1

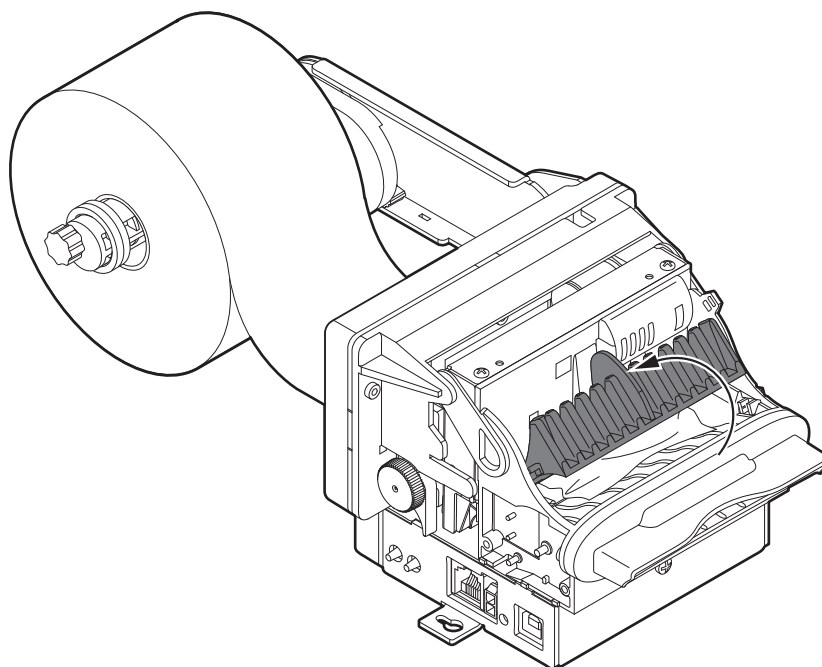

Lift up the inspection door.

2

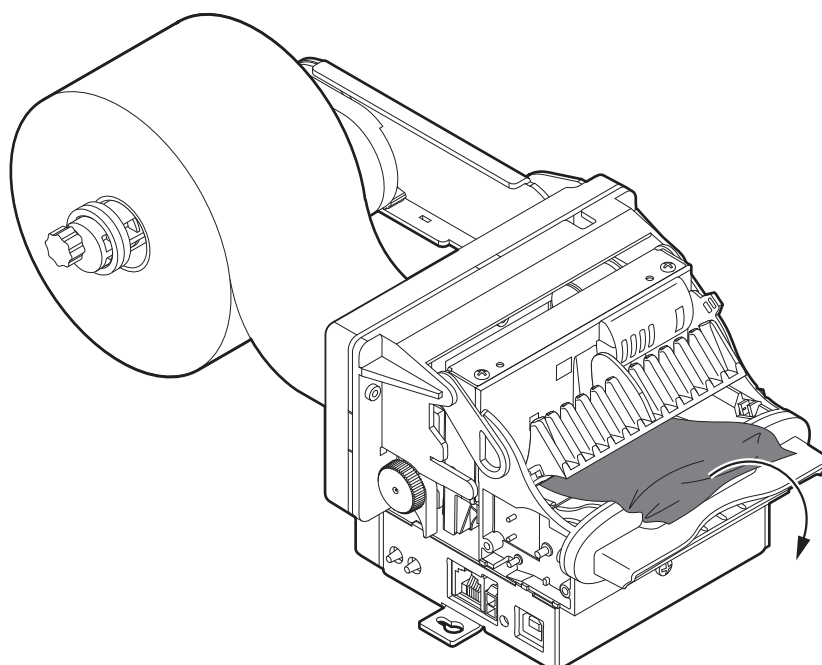

Remove any scraps of paper from the front side of the device.

3

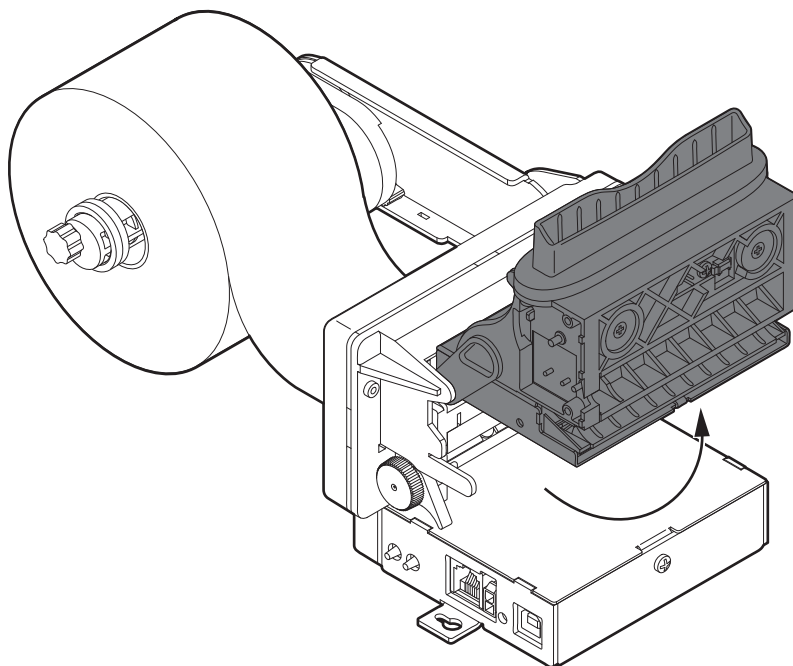

Open the device
(see [paragraph 4.1](#)).

4

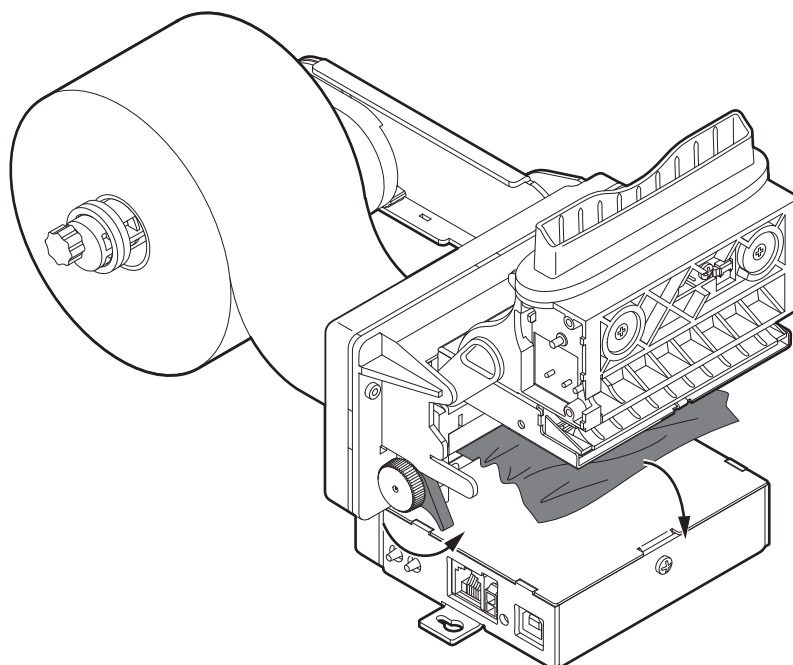

Lift the unlocking lever for the platen roller and remove any scraps of paper from the printing mechanism.
The printhead will return to its working position simply by releasing the lever.



BEFORE LIFTING THE UNLOCKING LEVER MAKE SURE THE AUTOCUTTER IS LIFTED UP

5

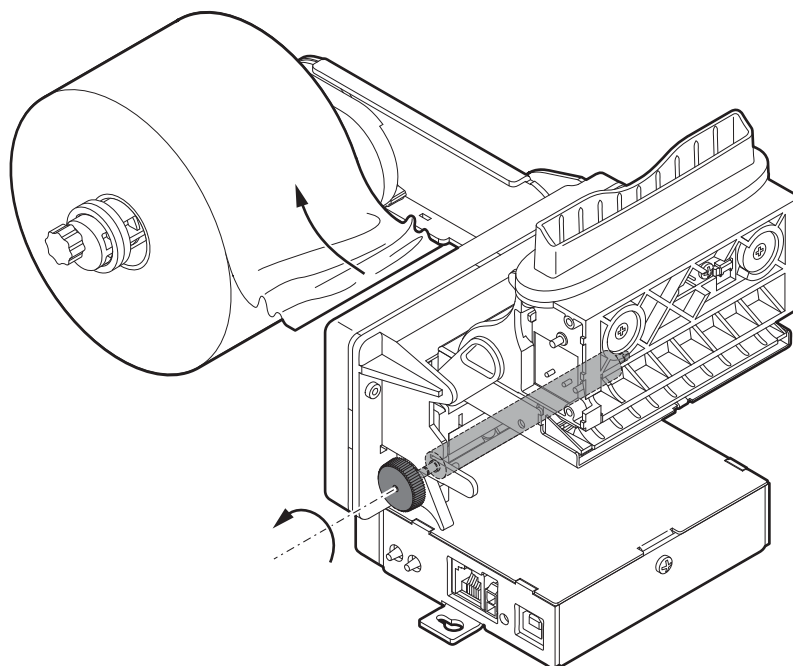

Rotate counter-clockwise the platen roller
and pull lightly the paper backwards to clear.



7.2 Planning of cleaning operations

The regular cleaning of the device keeps the print quality and extends its life. The following table shows the recommended planning for the cleaning operations. If you use the device in dusty environments, you must reduce the intervals between the cleaning operations.

For specific procedures, see the following pages.

EVERY PAPER CHANGE	
Platen roller	Use isopropyl alcohol
EVERY 5 PAPER CHANGES	
Paper path	Use compressed air or tweezers
Autocutter	Use compressed air
Sensors	Use compressed air
EVERY 6 MONTHS OR AS NEEDED	
Chassis	Use compressed air or a soft cloth

7.3 Cleaning

For periodic cleaning of the device, see the instructions below.

Platen roller

1

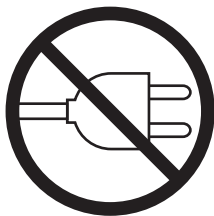

Disconnect the power supply cable and open the device (see [paragraph 4.1](#)).

2

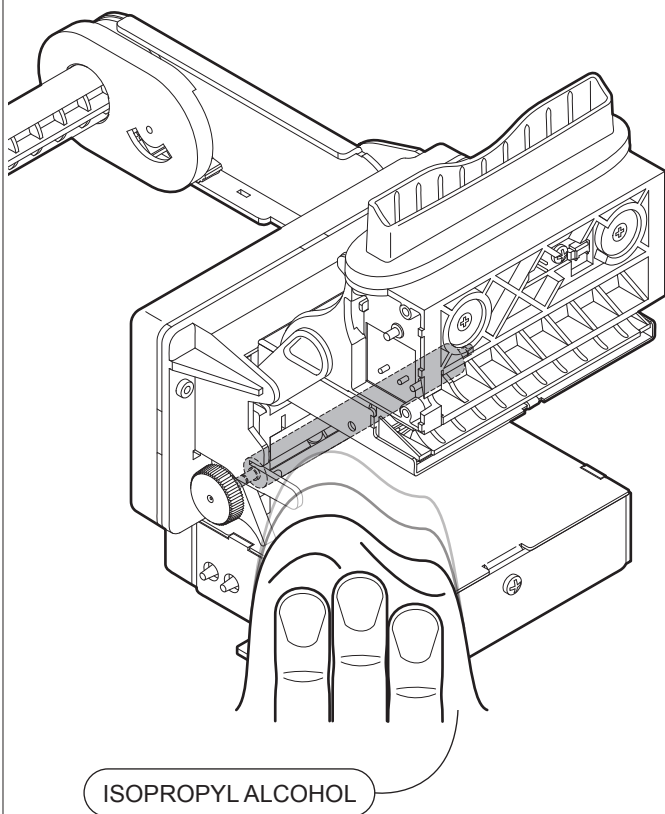

ATTENTION:
Do not use solvents, or hard brushes.
Do not let water or other liquids get inside the device.



Clean the platen roller by using a non-abrasive cloth moistened with isopropyl.

Autocutter

1

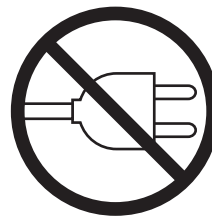

Disconnect the power supply cable and open the device (see [paragraph 4.1](#)).

2

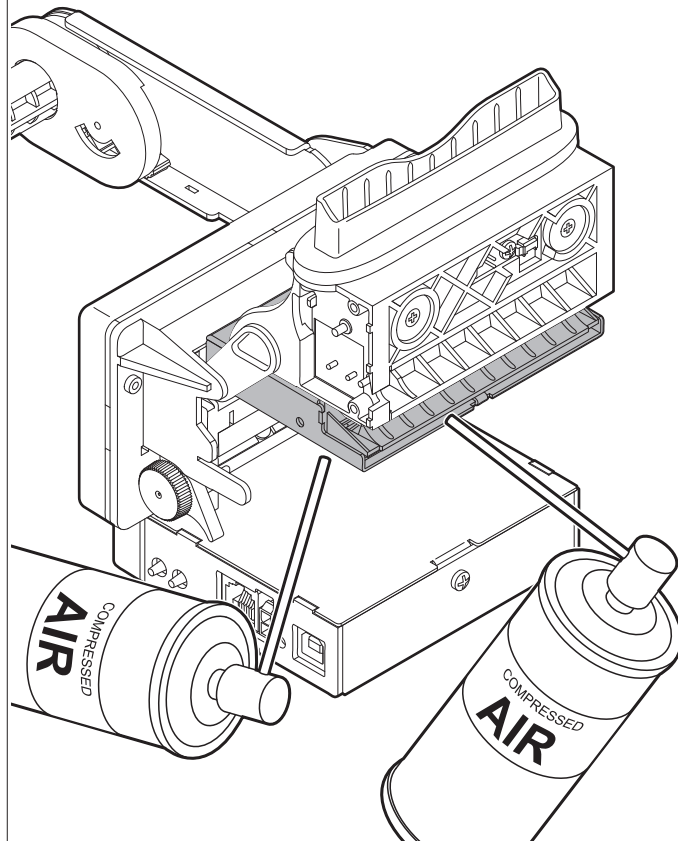

ATTENTION:
Do not use alcohol, solvents, or hard brushes.
Do not let water or other liquids get inside the device.



Remove any scraps of paper and the accumulated paper dust on the input and the output of autocutter.

Paper path

1

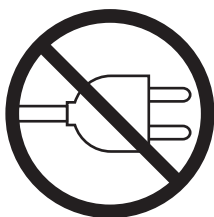

Disconnect the power supply cable and open the device (see paragraph 4.1).

2

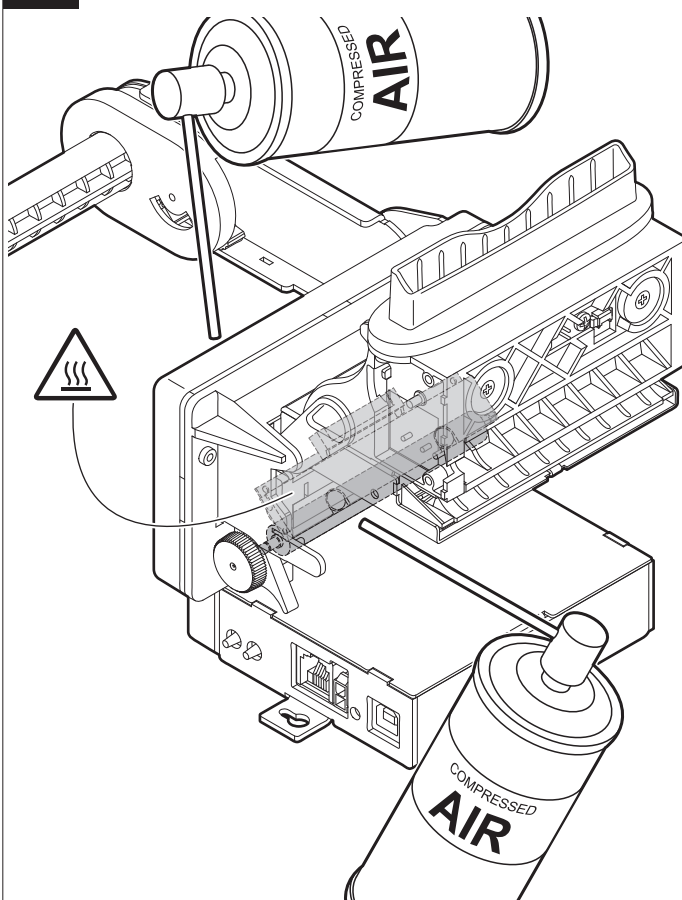

ATTENTION:

Do not use alcohol, solvents, or hard brushes.
Do not let water or other liquids get inside the device.



Remove any scraps of paper and the accumulated paper dust on the platen roller and in areas near to the paper presence sensor.

3

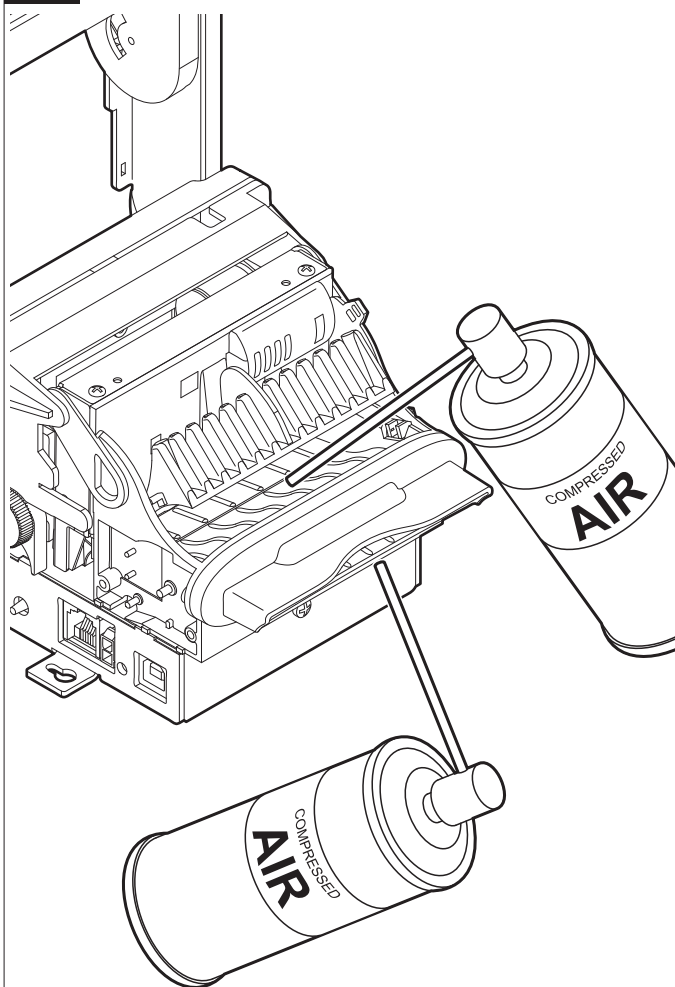

ATTENTION:

Do not use alcohol, solvents, or hard brushes.
Do not let water or other liquids get inside the device.



Remove any scraps of paper and the accumulated paper dust under the inspection door and on the paper output.

Sensors

1

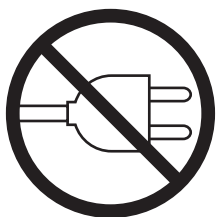

Disconnect the power supply and open the inspection door (see [paragraph 7.1](#)).

2

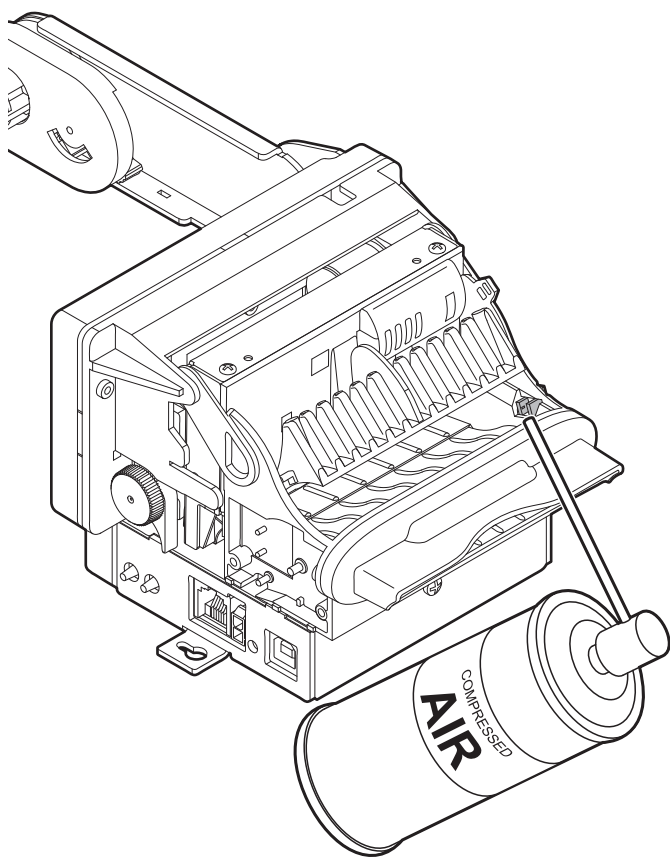

ATTENTION:
Do not use alcohol, solvents, or hard brushes.
Do not let water or other liquids get inside the machine.



Clean the anti-jamming sensor by using compressed air.

3

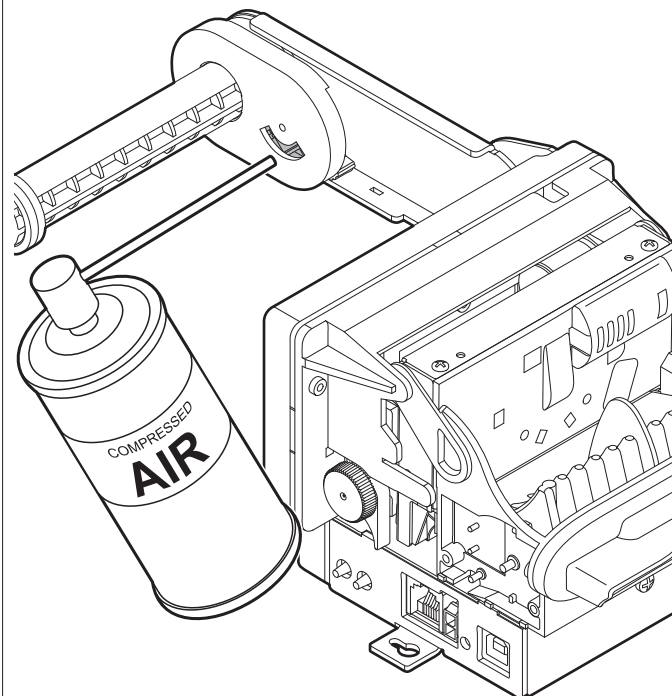

ATTENTION:
Do not use alcohol, solvents, or hard brushes.
Do not let water or other liquids get inside the machine.



Clean the low paper sensor by using compressed air.

Chassis

1

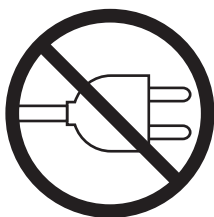

Disconnect the power supply cable.

2

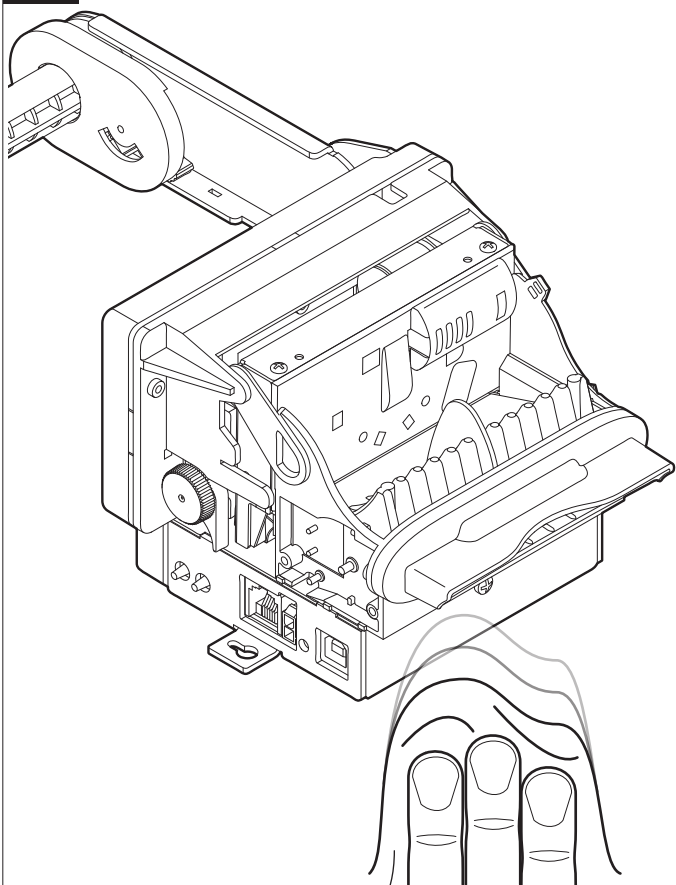

ISOPROPYL ALCOHOL

ATTENTION:

Do not use solvents, or hard brushes.

Do not let water or other liquids get inside the machine.



To clean the device,
use compressed air or a soft cloth.

7.4 Firmware upgrade

Firmware upgrade can be performed by using the “PrinterSet” software tool available on www.custom4u.it. To upgrade firmware, proceed as follows:

1

[WWW.CUSTOM4U.it](http://www.CUSTOM4U.it)

Login to the website www.custom4u.it, type in the product code of the device and download the latest firmware release available.

2

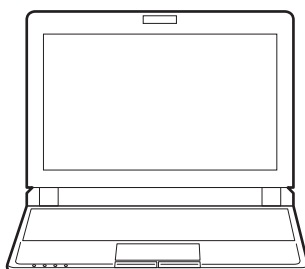

Connect the device to a PC directly (see [paragraph 3.3](#)), without using HUB devices.

3

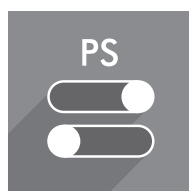

Start the “PrinterSet” software tool.



4

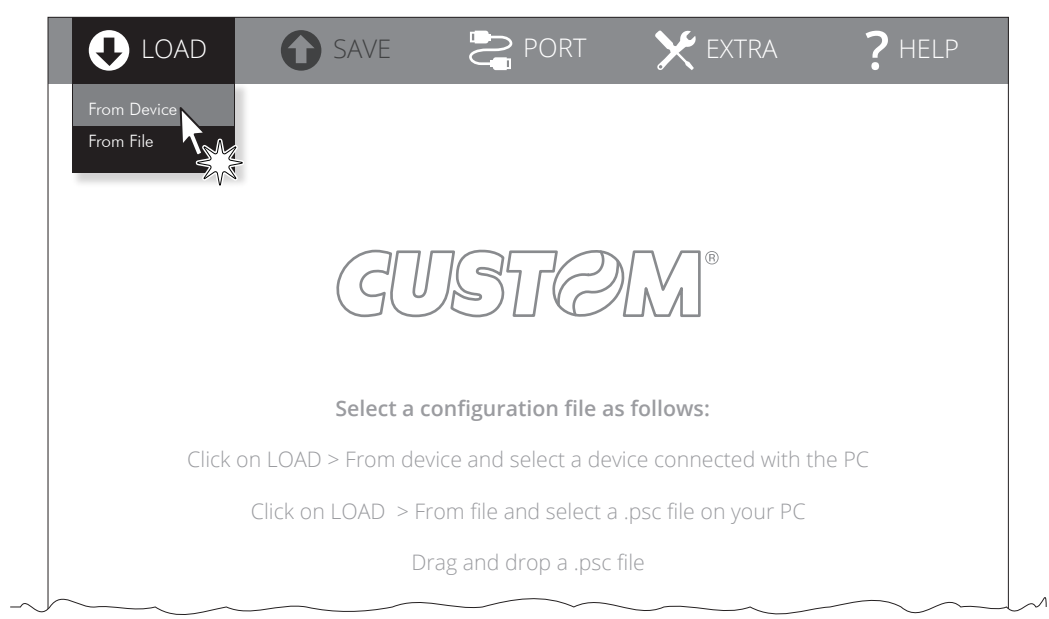

Click on LOAD > FROM DEVICE and select the device connected to the PC.

5

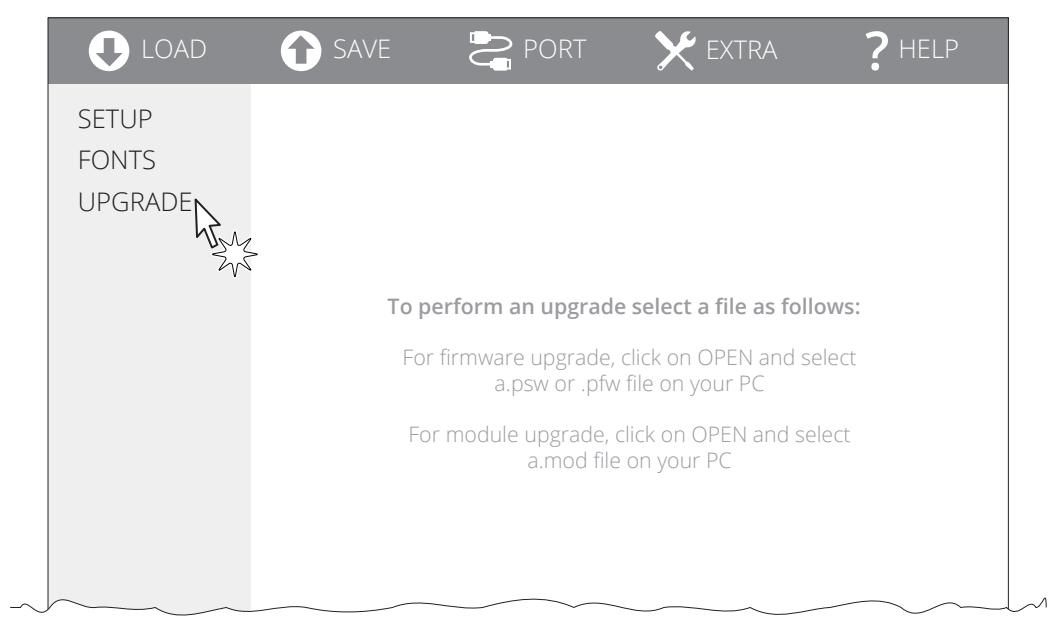

Click on UPGRADE and follow the instructions shown on the screen.

ATTENTION:
During saving, it is strongly discouraged to disconnect the communication cable or to remove the power supply of the PC or the device.



8 SPECIFICATION

8.1 Hardware specifications

GENERAL	
Sensors	Paper input and alignment black mark presence, head temperature, paper jam, inspection door open, early withdrawal of the ticket, external low paper (on paper roll holder)
Emulations	TGH, CUSTOM/POS
Printing driver	Windows XP Windows VISTA (32/64 bit) Windows 7 (32/64 bit) Windows 8 (32/64 bit) Windows 8.1 (32/64 bit) Windows 10 (32/64 bit) Self-installing driver for Virtual COM (32/64 bit) Linux (32/64 bit)
INTERFACES	
RS232 serial connector	from 9600 bps to 115200 bps
USB connector	12 Mbit/s
MEMORIES	
Receive buffer	8 kB
Flash memory	1 MB internal + 4 MB external
RAM memory	256 kB internal
Graphic memory	2 logos (608 x 430 dots)
PRINTER	
Resolution	203 dpi (8 dot/mm)
Printing method	Thermal, fixed head
Head life ⁽¹⁾	
Abrasion resistance ⁽²⁾	50 km (with recommended paper, 12.5% duty cycle)
Pulse durability	100 M (referred to each dot)



Printing width	76 mm, 80 mm
Printing mode	Normal, 90°, 180°, 270°
Printing format	Height/width from 1 to 8, bold, reverse, underlined, italic
Character fonts	55 character code tables (see paragraph 8.6) Extended chinese GB18030-2000 Korean CP949
Printable barcode	Codabar, Code 32, Code 39, Code 93, Code 128, EAN-8, EAN-13, ITF, UPC-A, UPC-E, Data Matrix, PDF417, QRCode
Printing speed ^{(1) (3)}	Normal = 95 mm/s High Speed = 120 mm/s

PAPER

Type of paper	Thermal rolls, heat-sensitive side on outside of roll
Paper width	from 76 mm ± 0.5 mm to 80 mm ± 0.5 mm
Paper weight	from 55 g/m ² to 80 g/m ²
Paper thickness	60 µm ± 0.5 µm (for 55 g/m ² paper) 85 µm ± 0.6 µm (for 80 g/m ² paper)
Recommended types of paper	KANZAN KF50 o KP460 MITSUBISHI PF5067 o TL4000
External roll diameter	max 90 mm
Paper end	Not attached to roll core
Internal roll core diameter	25 mm
Core type	Cardboard or plastic
Minimum ticket length	87 mm

AUTOCUTTER

Paper cut	Total cut
Estimated life ⁽¹⁾	1000000 cuts (with paper thickness 100 µm, ambient temperature)



DEVICE ELECTRICAL SPECIFICATIONS

Power supply	24 Vdc \pm 10%
Medium consumption ⁽⁴⁾	2.2 A max
Typical consumption ⁽³⁾	0.88 A
Standby consumption	0.03 A
Low energy mode consumption	0.012 A

ELECTRICAL SPECIFICATIONS POWER SUPPLY code 963GE020000071 (optional)

Power supply voltage	from 90 Vac to 264 Vac
Frequency	from 47 Hz to 63 Hz
Output	24 V, 2.5 A
Power	60 W

ENVIRONMENTAL CONDITIONS

Operating temperature	from -20 °C to +70 °C ⁽⁵⁾
Relative humidity (RH)	from 10% to 85% (without condensation)
Storage temperature	from -20 °C to +70 °C
Storage relative humidity (RH)	from 10% to 90% (without condensation)

NOTES:

- (1) : Respecting the regular schedule of cleaning for the device components.
- (2) : Damages caused by scratches, ESD and electromigration are excluded.
- (3) : Referred to a standard CUSTOM receipt (L = 10 cm, Density = 12.5% dots on).
- (4) : Referred to the UL measurements (Ticket 12.5% dots on, Ticket length 10 cm, Print density +50%, Printing loop 30 s).
- (5) : If you use the device with the power supply code 963GE020000071, supplied as an accessory, the operating temperature range is from 0 °C to +40 °C.



8.2 Character specifications

Character set		3	
Character density	11 cpi	15 cpi	20 cpi
Number of columns	35	49	64
Chars / seconds	1400	1960	2560
Lines / seconds	40	40	40
Characters (L x H mm) - Normal	2.25 x 3	1.625 x 3	1.25 x 3

NOTE:
Theoretical values.

8.3 Device dimensions

Length	271.5 mm
Height	102 mm
Width	130.2 mm
Weight	1130 g

Data refer to device with paper roll holder assembled in the rear position (see [paragraph 3.2](#)).
All the dimensions shown in following figure are in millimetres.

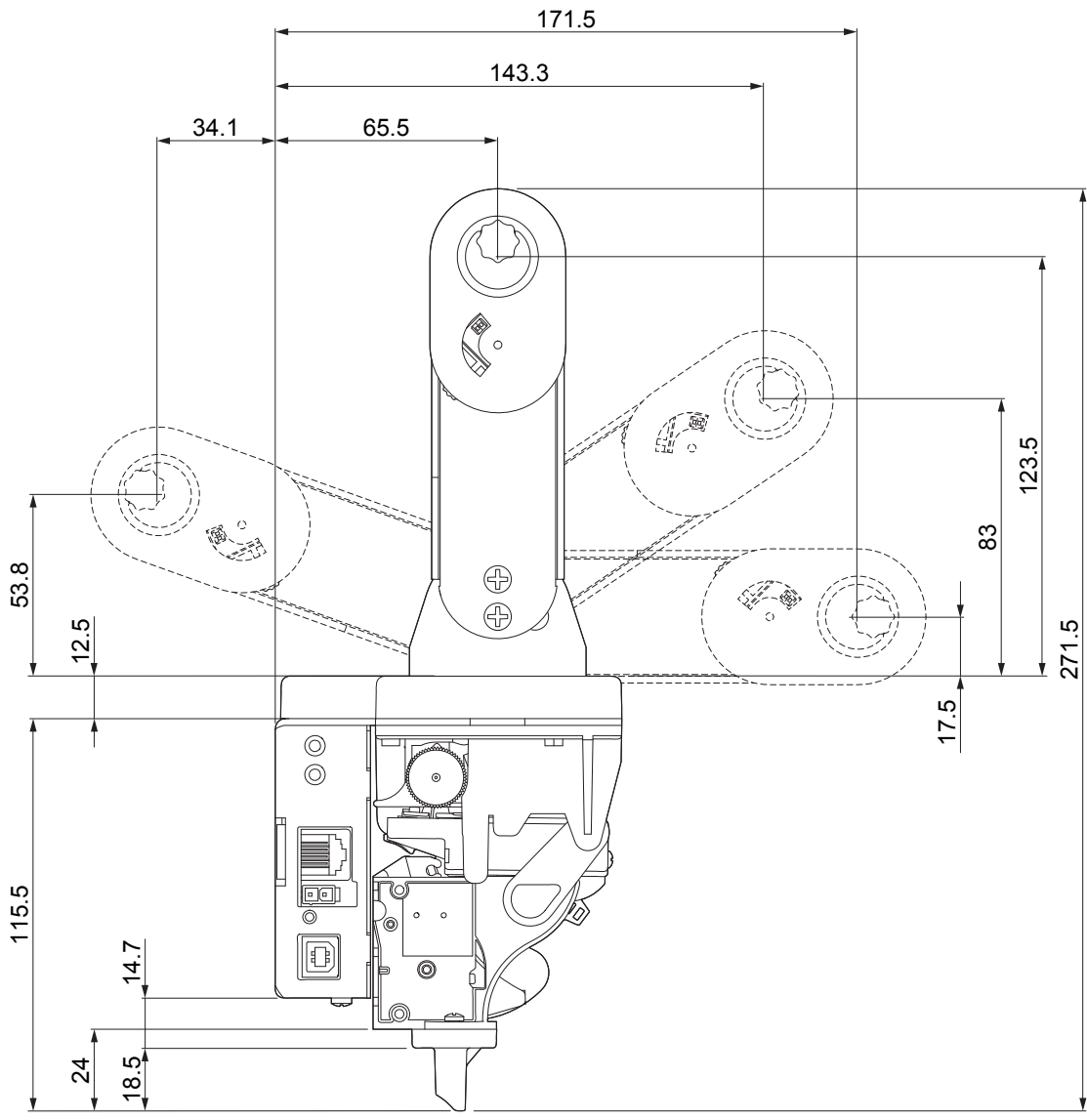
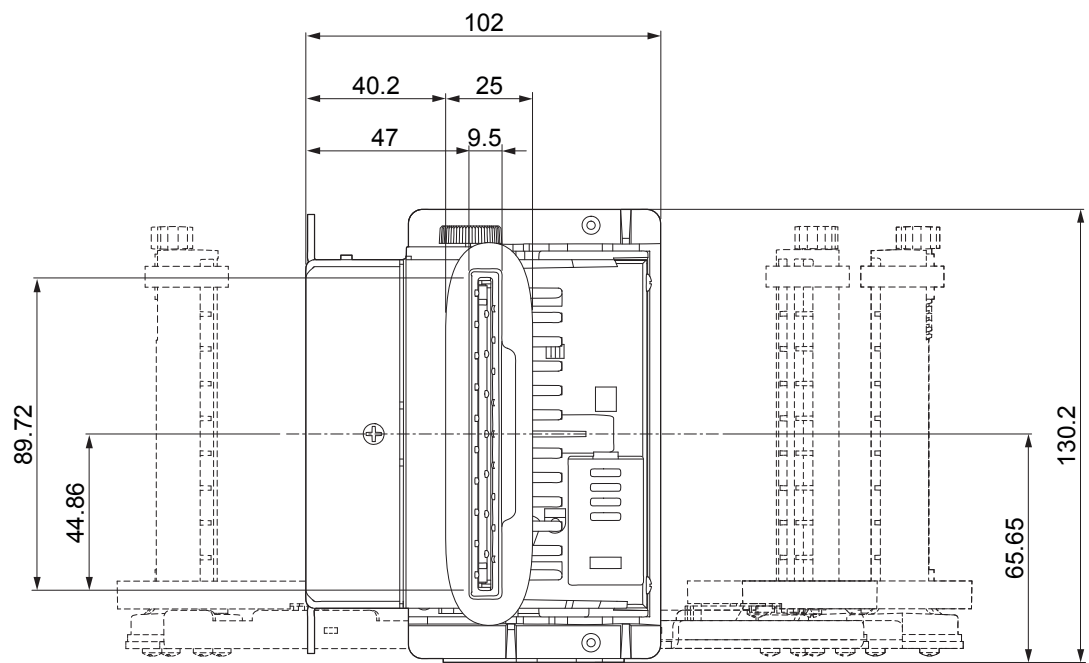



8.4 Power supply, power cord and adapter for power supply dimensions (optionals)

The following table shows the dimensions of the power supply, the power cord and the adapter for power supply optionals for the device:

POWER CORD code 26100000000311	
Length	2000 mm
ADAPTER FOR POWER SUPPLY code 26900000000005	
Length	200 mm
POWER SUPPLY code 963GE020000071	
Length	130 mm
Height	36 mm
Width	57 mm

All the dimensions shown in following figures are in millimetres.

POWER CORD code 26100000000311

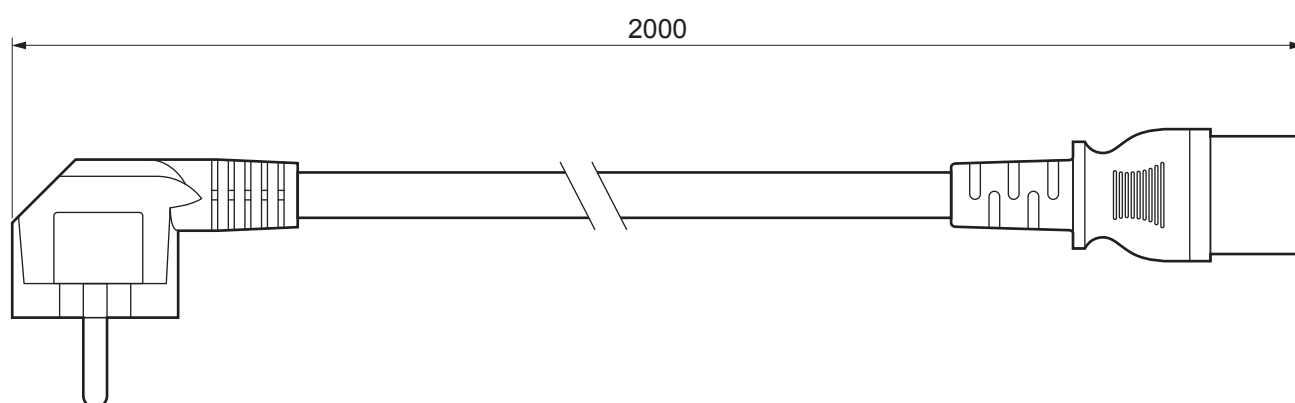



ADAPTER FOR POWER SUPPLY code 2690000000005

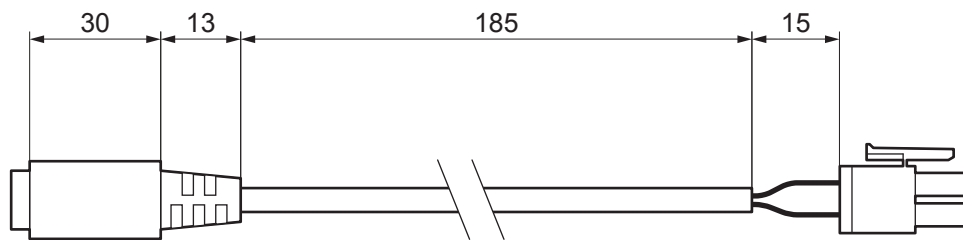

POWER SUPPLY code 963GE020000071

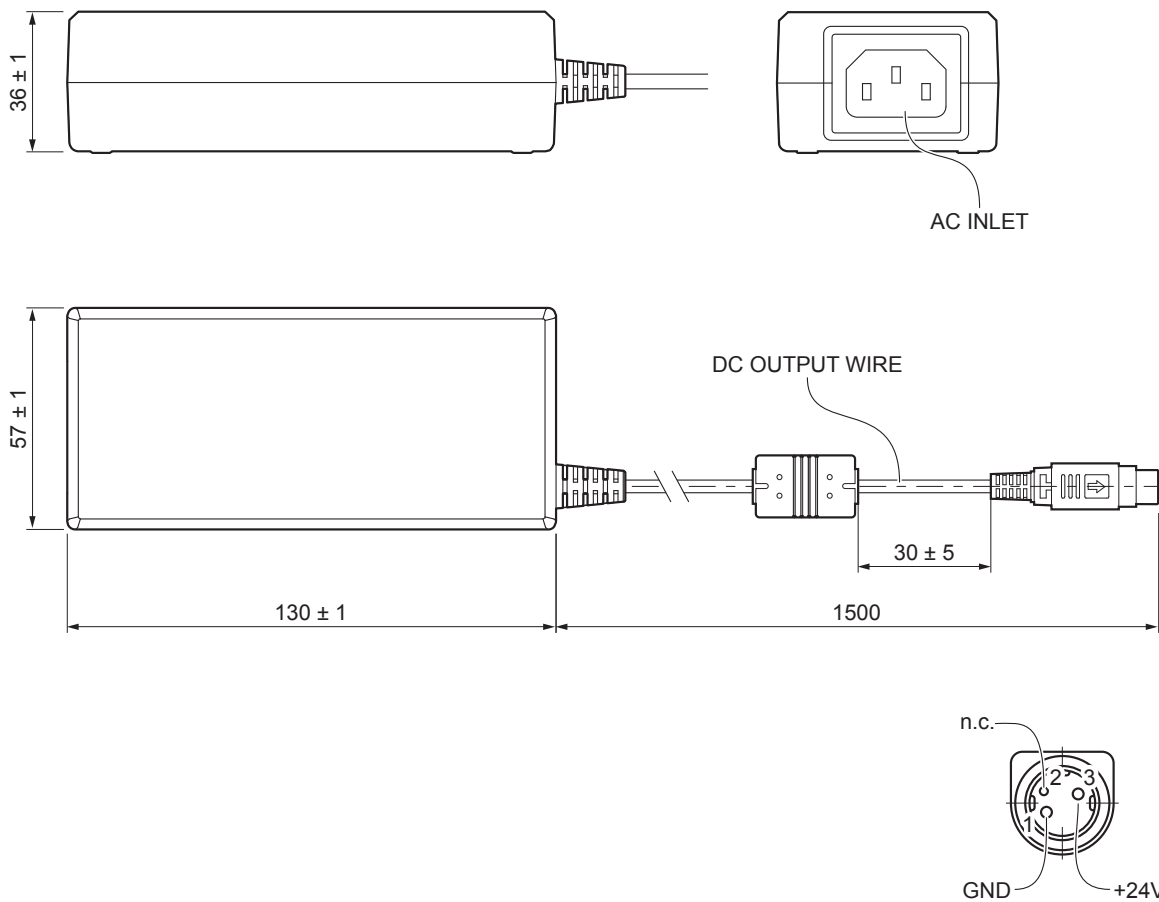

8.5 Paper specification

The following image shows an example of black mark placement on the non-thermal side of paper. All the dimensions shown in the following figure are in millimetres.

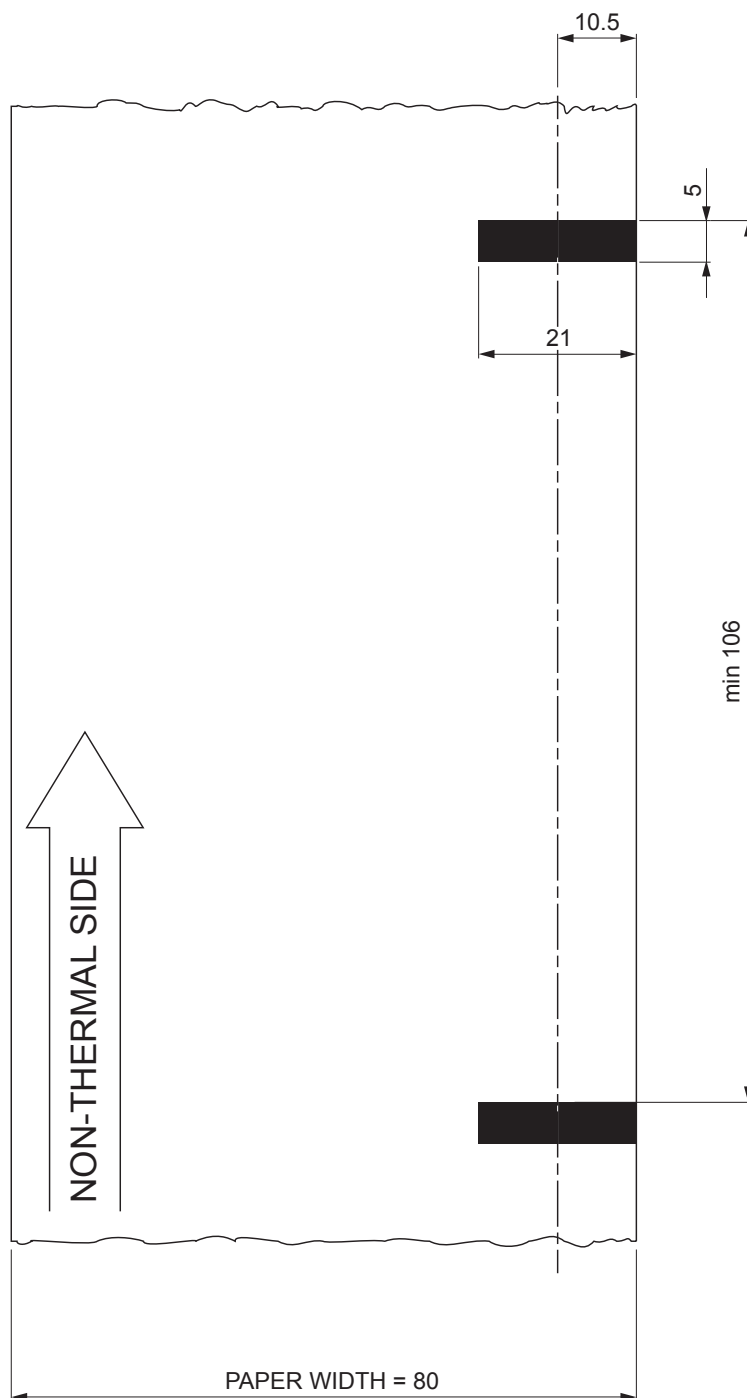



8.6 Character sets

The device has 3 fonts of varying width (11, 15 and 20 cpi) which may be related one of the coding tables provided on the device.

To know the coding tables actually present on the device, you need to print the font test (see [paragraph 2.4](#)).

You can set font and coding table by using the commands (see the commands manual of the device) or using the “Code Table” and the “Chars / Inch” parameters during the setup procedure (see [paragraph 5.5](#)).

The following is the full list of coding tables that can be installed on the device.

<CodeTable>	Coding table	
0	PC437 - U.S.A., Standard Europe	
1	Katakana	
2	PC850 - Multilingual	
3	PC860 - Portuguese	
4	PC863 - Canadian/French	
5	PC865 - Nordic	
6	VISCII - Vietnamese Standard Code	
11	PC851 - Greek	on request
12	PC853 - Turkish	on request
13	PC857 - Turkish	
14	PC737 - Greek	
15	ISO8859-7 - Greek	on request
16	WPC1252 - Scandinavian	
17	PC866 - Cyrillic 2	
18	PC852 - Latin 2	
19	PC858 for Euro symbol in position 213	
20	FKU42 - Thai	
21	TIS11 - Thai	on request
26	TIS18 - Thai	on request
30	TCVN_3 - Vietnamese	on request
31	TCVN_3 - Vietnamese	on request
32	PC720 - Arabic	on request
33	WPC775 - Baltic Rim	on request



<CodeTable>	Coding table
34	PC855 - Cyrillic
35	PC861 - Icelandic on request
36	PC862 - Hebrew
37	PC864 - Arabic
38	PC869 - Greek on request
39	ISO8859-2 - Latin 2 on request
40	ISO8859-15 - Latin 9 on request
41	PC1098 - Farsi
42	PC1118 - Lithuanian on request
43	PC1119 - Lithuanian on request
44	PC1125 - Ukrainian
45	WPC1250 - Latin 2
46	WPC1251 - Cyrillic
47	WPC1253 - Greek
48	WPC1254 - Turkish
49	WPC1255 - Hebrew
50	WPC1256 - Arabic
51	WPC1257 - Baltic Rim
52	WPC1258 - Vietnamese
53	KZ1048 - Kazakh on request
255	Space page

9 CONSUMABLES

The following table shows the list of available consumables for device:

67300000000406

THERMAL PAPER ROLL

width = 80 mm

Ø external = 90 mm

Ø core = 25 mm

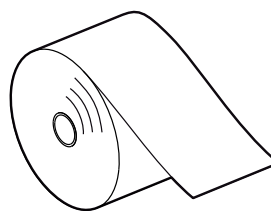



10 ACCESSORIES

The following table shows the list of available accessories for device:

963GE020000071

POWER SUPPLY
(for technical specifications, see [paragraph 8.1](#))

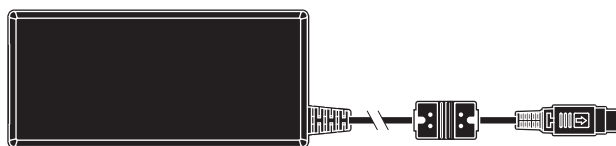

26100000000311

POWER CORD SCHUKO PLUG
length = 2 m
(see [paragraph 8.4](#))



26900000000005

ADAPTER CABLE FOR POWER SUPPLY
length = 200 mm
(see [paragraph 8.4](#))



26500000000311

SERIAL CABLE RJ-DB9F
Length = 1.5 m



21400000000040

DARK PAPER BEZEL

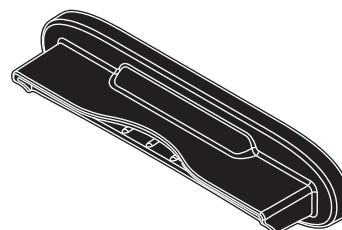

81300000000068

BOARD TOP BLACK MARK

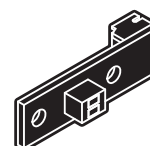





11 TECHNICAL SERVICE

In case of failure, contact the technical service accessing the website www.custom4u.it and using the support tools on the homepage. It is advisable to keep the identification data of the product at hand.

The product code, the serial number and the hardware release number can be found on the product label (see [paragraph 2.3](#)).

The firmware release number (SCODE) can be found:

- on the setup report (see [paragraph 5.1](#))
- connecting the device to a PC and starting the "PrinterSet" tool (see [paragraph 5.2](#))



CUSTOM[®]

CUSTOM S.p.A.

World Headquarters

Via Berettine, 2/B - 43010 Fontevivo, Parma ITALY

Tel. +39 0521 680111 - Fax +39 0521 610701

info@custom.biz - www.custom.biz

All rights reserved