

**PEX-1120/ PEX-1130/ PEX-1160 SERIES
PEX-1220/ PEX-1230/ PEX-1260 SERIES**

**THERMAL TRANSFER / DIRECT THERMAL
PRINT ENGINE**

**USER'S
MANUAL**

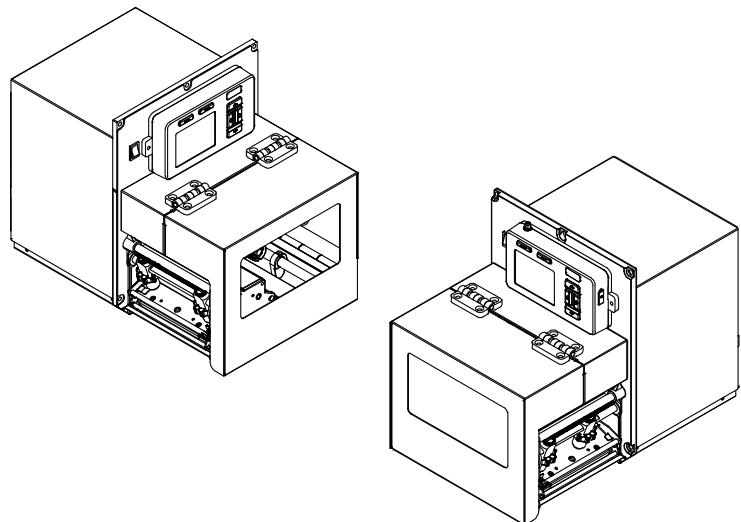

Copyright Information

©2018 TSC Auto ID Technology Co., Ltd,

The copyright in this manual, the software and firmware in the print engine described therein are owned by TSC Auto ID Technology Co., Ltd, All rights reserved.

CG Triumvirate is a trademark of Agfa Corporation. CG Triumvirate Bold Condensed font is under license from the Monotype Corporation. Windows is a registered trademark of Microsoft Corporation.

All other trademarks are the property of their respective owners.

Information in this document is subject to change without notice and does not represent a commitment on the part of TSC Auto ID Technology Co. No part of this manual may be reproduced or transmitted in any form or by any means, for any purpose other than the purchaser's personal use, without the expressed written permission of TSC Auto ID Technology Co.

Agency Compliance and Approvals



EN 55022, Class A
EN 55024
EN 60950-1/ EN 62368-1
EN 61000-3-2
EN 61000-3-3

This is a class A product. In a domestic environment this product may cause radio interference in which case the user may be required to take adequate measures.



FCC part 15B, Class A
ICES-003, Class A

This equipment has been tested and found to comply with the limits for a Class A digital device, pursuant to Part 15 of the FCC Rules. These limits are designed to provide reasonable protection against harmful interference when the equipment is operated in a commercial environment.

This equipment generates, uses, and can radiate radio frequency energy and, if not installed and used in accordance with the manufacturer's instruction manual, may cause harmful interference with radio communications. Operation of this equipment in a residential area is likely to cause harmful interference, in which case you will be required to correct the interference at your own expense.

This Class A digital apparatus complies with Canadian ICES-003.

Cet appareil numérique de la classe A est conform à la norme NMB-003 du Canada.

This device complies with Part 15 of the FCC Rules. Operation is subject to the following two conditions: (1) This device may cause harmful interference, and (2) this device must accept any interference received, including interference that may cause undesired operation.



AS/NZS CISPR 32, Class A



GB 4943.1
GB 9254
GB 17625.1

此为 A 级产品，在生活环境中，该产品可能会造成无线电干扰，在这种情况下，可能需要用户对干扰采取切实可行的措施。



IS 13252(Part 1)/
IEC 60950-1



TP TC 004
TP TC 020



CNS 13438
CNS 14336-1
CNS 15663



LP0002 Section 3.10

Important safety instructions:

1. Read all of these instructions and keep them for later use.
2. Follow all warnings and instructions on the product.
3. Disconnect the power plug from the AC outlet before cleaning or if fault happened.
Do not use liquid or aerosol cleaners. Using a damp cloth is suitable for cleaning.
4. The mains socket shall be installed near the equipment and easily accessible.
5. The unit must be protected against moisture.
6. Ensure the stability when installing the device, Tipping or dropping could cause damage.
7. Make sure to follow the correct power rating and power type indicated on marking label provided by manufacture.
8. Please refer to user manual for maximum operation ambient temperature.

WARNING:

Hazardous moving parts, keep fingers and other body parts away.

CAUTION:

(For equipment with RTC (CR2032) battery or rechargeable battery pack)

Risk of explosion if battery is replaced by an incorrect type.

Dispose of used batteries according to the Instructions as below.

1. DO NOT throw the battery in fire.
2. DO NOT short circuit the contacts.
3. DO NOT disassemble the battery.
4. DO NOT throw the battery in municipal waste.
5. The symbol of the crossed out wheeled bin indicates that the battery should not be placed in municipal waste.



Caution: The printhead may be hot and could cause severe burns. Allow the printhead to cool.

CAUTION:

For operation safety, please turn off the power by the power switch before opening the media cover to load labels, ribbons, or to repair. After completing the steps, please close the media cover first and then turn on the power to start printing.

CAUTION:

Any changes or modifications not expressly approved by the grantee of this device could void the user's authority to operate the equipment.

Below statement are for product with optional RF function.

CE Statement:

All operational modes:

2.4GHz: 802.11b, 802.11g, 802.11n (HT20), 802.11n (HT40)

5GHz: 802.11a,

The frequency, mode and the maximum transmitted power in EU are listed below:

2400 MHz – 2483.5 MHz: 19.88 dBm (EIRP)(Wi-Fi)

5150 MHz – 5250 MHz: 17.51 dBm (EIRP)(Wi-Fi)

2402 MHz – 2480 MHz: 6.02 dBm (EIRP)(Bluetooth)

Requirements in

AT/BE/BG/CZ/DK/EE/FR/DE/IS/IE/IT/EL/ES/CY/LV/LI/LT/LU/HU/MT/NL/NO/PL/PT/RO/SI/SK/TR/FI/SE/CH/UK/HR. 5150MHz~5350MHz is for indoor use only.

5150-5350MHz for Only indoor use

5470-5725MHz for indoor/outdoor use



Restrictions In AZE

National restrictions information is provided below

Frequency Band	Country	Remark
5150-5350MHz	Azerbaijan	No license needed if used indoor and power not exceeding 30mW
5470-5725MHz		

Hereby, TSC Auto ID Technology Co., Ltd. declares that the radio equipment type [Wi-Fi] IEEE 802.11 a/b/g/n and Bluetooth are in compliance with Directive 2014/53/EU

The full text of the EU declaration of conformity is available at the following internet address:

<https://www.tscprinters.com/>

Canada, Industry Canada (IC) Notices

This Class B digital apparatus complies with Canadian ICES-003 and RSS-210.

Operation is subject to the following two conditions: (1) this device may not cause interference, and (2) this device must accept any interference, including interference that may cause undesired operation of the device.

Canada, avis de l'Industry Canada (IC)

Cet appareil numérique de classe B est conforme aux normes canadiennes ICES-003 et RSS-210.

Son fonctionnement est soumis aux deux conditions suivantes : (1) cet appareil ne doit pas causer d'interférence et (2) cet appareil doit accepter toute interférence, notamment les interférences qui peuvent affecter son fonctionnement.

NCC 警語:

經型式認證合格之低功率射頻電機，非經許可，公司、商號或使用者均不得擅自變更頻率、加大功率或變更原設計之特性及功能。(即低功率電波輻射性電機管理辦法第十二條)

低功率射頻電機之使用不得影響飛航安全及干擾合法通信；經發現有干擾現象時，應立即停用，並改善至無干擾時方得繼續使用。

前項合法通信，指依電信法規定作業之無線電通信。低功率射頻電機須忍受合法通信或工業、科學及醫療用電波輻射性電機設備之干擾。(即低功率電波輻射性電機管理辦法第十四條)

BSMI Class A 警語:

這是甲類的資訊產品，在居住的環境使用中時，可能會造成射頻干擾，在這種情況下，使用者會被要求採取某些適當的對策。

單元 Unit	限用物質及其化學符號 Restricted substances and its chemical symbols					
	鉛 Lead (Pb)	汞 Mercury (Hg)	鎘 Cadmium (Cd)	六價鉻 Hexavalent chromium (Cr+6)	多溴聯苯 Polybrominated biphenyls (PBB)	多溴二苯醚 Polybrominated diphenyl ethers (PBDE)
內外塑膠件	○	○	○	○	○	○
內外鐵件	-	○	○	○	○	○
滾輪	○	○	○	○	○	○
銘版	○	○	○	○	○	○
電路板	-	○	○	○	○	○
晶片電阻	-	○	○	○	○	○
積層陶瓷表面黏著電容	○	○	○	○	○	○
集成電路-IC	-	○	○	○	○	○
電源供應器	○	○	○	○	○	○
印字頭	-	○	○	○	○	○
馬達	-	○	○	○	○	○
液晶顯示器	-	○	○	○	○	○
插座	-	○	○	○	○	○
線材	-	○	○	○	○	○

備考 1. “超出 0.1 wt %” 及 “超出 0.01 wt %” 係指限用物質之百分比含量超出百分比含量基準值。
Note 1 : “Exceeding 0.1 wt %” and “exceeding 0.01 wt %” indicate that the percentage content of the restricted substance exceeds the reference percentage value of presence condition.

備考 2. “○” 係指該項限用物質之百分比含量未超出百分比含量基準值。
Note 2 : “○” indicates that the percentage content of the restricted substance does not exceed the percentage of reference value of presence.

備考 3. “-” 係指該項限用物質為排除項目。
Note 3 : The “-” indicates that the restricted substance corresponds to the exemption.

Contents

- 1. Introduction 1
 - 1.1 Product Introduction 1
 - 1.2 Product Features 2
 - 1.2.1 Standard Features..... 2**
 - 1.2.2 Optional Features..... 4**
 - 1.3 Print Engine Specifications..... 4
 - 1.4 Print Specifications 5
 - 1.5 Ribbon Specifications 5
 - 1.6 Media Specifications 6
- 2. Operations Overview 7
 - 2.1 Unpacking and Inspection 7
 - 2.2 Print Engine Orientation 8
 - 2.3 Checking the Installation Space 9
 - 2.4 Print Engine Overview 13
 - 2.4.1 Front View 13**
 - 2.4.2 Interior view 14**
 - 2.4.3 Rear View 15**
 - 2.5 Operator Control..... 16
 - 2.5.1 LED Indication 16**
 - 2.5.2 Keys..... 16**
 - 2.5.2 Main page Icons 17**
- 3. Setup 18
 - 3.1 Setting up the print engine 18
 - 3.2 Loading the Ribbon 19
 - 3.3 Loading the Media..... 22
 - 3.3.1 Loading the Media..... 22**
 - 3.3.2 Loading Media in Peel-off Mode 25**
- 4. Moveable Print Head Pressure Adjustment Knob 28
 - 4.1 Mechanism Fine Adjustment to Avoid Ribbon Wrinkles 29
- 5. Ribbon Tension Adjustment Knob 30
 - 5.1 Suggestion of Ribbon Tension Adjustment..... 31
- 6. Diagnostic Tool..... 33

6.1 Start the Diagnostic Tool	33
6.2 Function	34
6.3 Setting Ethernet by Diagnostic Tool	35
6.3.1 Using USB interface to setup Ethernet interface.....	35
6.3.2 Using RS-232 interface to setup Ethernet interface	36
6.3.3 Using Ethernet interface to setup Ethernet interface.....	37
7. LCD Menu Function	39
7.1 Enter the Menu	39
7.2 Menu Overview.....	40
7.3 Setting.....	41
7.3.1 TSPL	41
7.3.2 ZPL2	43
7.4 Sensor	46
7.5 Interface.....	47
7.5.1 Serial Comm.....	47
7.5.2 Ethernet	48
7.5.3 Wi-Fi	48
7.5.4 Bluetooth	49
7.5.5 GPIO	49
7.6 Advanced.....	51
7.7 File Manager.....	53
7.8 Diagnostic.....	54
7.9 Favorites	56
8 Troubleshooting.....	58
9 Maintenance	61
Revise History	62

1. Introduction

1.1 Product Introduction

Thank you very much for purchasing TSC bar code print engine.

TSC's innovative PEX-1000 Series print engine incorporates a robust die cast construction designed for years of reliability, ease of use, and cost-conscious serviceability. The PEX combines a precision print mechanism with high performance electronics to produce labels at up to 18 inches per second, the fastest in its class.

Designed for ease of integration, the PEX features a bolt-compatible construction with a commonly used GPIO interface and an easy to use color display. The PEX offers simple integration into both new and existing label application installations. It is ideal for manufacturing and logistic applications where high speed and high demand label printing is required.

This document provides an easy reference for operating the PEX-1000 Series. To print label formats, please refer to the TSPL/TSPL2 programming manual for writing the custom programs, the TSPL/TSPL2 programming manual can be found on the accessories CD-ROM or on TSC website at <https://www.tscprinters.com>.

- Applications
 - Manufacturing
 - Automotive
 - Food and Beverage
 - Warehouse & Logistics
 - Pallet Labeling
 - Carton Shipping
 - Healthcare
 - Pharmaceutical labeling

1.2 Product Features

1.2.1 Standard Features

The print engine offers the following standard features.

Standard feature	
Printing method	Thermal transfer and direct thermal
LCD display/ Operation buttons	<ul style="list-style-type: none"> ▪ Multi-language selectable ▪ 3.5" color TFT display, 320 x 240 pixel ▪ Six operation buttons ▪ One LED Indication
Processor	32-bit RISC multi-tasking 536 MHz high performance processor
Memory	<ul style="list-style-type: none"> ▪ 512 MB Flash memory ▪ 512 MB SDRAM memory (DDR2) ▪ Support USB memory sticker (FAT32) ▪ Micro SD card reader for memory expansion, up to 32GB
Interface	<ul style="list-style-type: none"> ▪ RS-232 (Max. 115,200 bps) ▪ USB 2.0 (High speed mode) ▪ Internal Ethernet print server (10/100 Mbps) ▪ USB host (Front side, connecting USB storage device) ▪ GPIO (Applicator interface with DB15F connector +5V I/O) + Parallel
Sensors	<ul style="list-style-type: none"> ▪ Gap transmissive sensor (Position adjustable, 15mm → 98mm) ▪ Black mark reflective sensor (Position adjustable, 15mm → 92mm) ▪ Ribbon end sensor (transmissive) ▪ Ribbon encoder sensor ▪ Head open sensor ▪ Media cover open sensor
Internal font	<ul style="list-style-type: none"> ▪ 8 alpha-numeric bitmap fonts ▪ One Monotype Imaging® CG Triumvirate Bold Condensed scalable font ▪ Built-in Monotype True Type font engine
Supported code page	<ul style="list-style-type: none"> ▪ Codepage 437 (English - US) ▪ Codepage 737 (Greek) ▪ Codepage 850 (Latin-1) ▪ Codepage 852 (Latin-2) ▪ Codepage 855 (Cyrillic) ▪ Codepage 857 (Turkish) ▪ Codepage 860 (Portuguese) ▪ Codepage 861 (Icelandic) ▪ Codepage 862 (Hebrew) ▪ Codepage 863 (French Canadian) ▪ Codepage 864 (Arabic) ▪ Codepage 865 (Nordic) ▪ Codepage 866 (Russian) ▪ Codepage 869 (Greek 2) ▪ Codepage 950 (Traditional Chinese) ▪ Codepage 936 (Simplified Chinese) ▪ Codepage 932 (Japanese) ▪ Codepage 949 (Korean)

	<ul style="list-style-type: none"> ▪ Codepage 1250 (Latin-2) ▪ Codepage 1251 (Cyrillic) ▪ Codepage 1252 (Latin-1) ▪ Codepage 1253 (Greek) ▪ Codepage 1254 (Turkish) ▪ Codepage 1255 (Hebrew) ▪ Codepage 1256 (Arabic) ▪ Codepage 1257 (Baltic) ▪ Codepage 1258 (Vietnam) ▪ ISO-8859-1: Latin-1 (Western European) ▪ ISO-8859-2: Latin-2 (Central European) ▪ ISO-8859-3: Latin-3 (South European) ▪ ISO-8859-4: Latin-4 (North European) ▪ ISO-8859-5: Cyrillic ▪ ISO-8859-6: Arabic ▪ ISO-8859-7: Greek ▪ ISO-8859-8: Hebrew ▪ ISO-8859-9: Turkish ▪ ISO-8859-10: Nordic ▪ ISO-8859-15: Latin-9 ▪ UTF-8 				
Supported bar code	<table border="1"> <thead> <tr> <th>1D bar code</th> <th>2D bar code</th> </tr> </thead> <tbody> <tr> <td>Code 11, Code 39, Code 49, Code 93, Code128UCC, Code128 subsets A.B.C, Codabar, Standard 2 of 5, Industrial 2 of 5, Interleave 2 of 5, EAN-8, EAN-13, EAN-14, EAN-128, ITF14, UPC-A, UPC-E, EAN and UPC 2(5) digits add-on, MSI, PLESSEY, PLANET, POSTNET, RSS-Stacked, GS1 DataBar, China Post, Telepen, LOGMARS</td> <td>CODABLOCK F mode, DataMatrix, Maxicode, Micro PDF-417, Aztec, MicroPDF417, QR code, RSS Barcode (GS1 Databar)</td> </tr> </tbody> </table>	1D bar code	2D bar code	Code 11, Code 39, Code 49, Code 93, Code128UCC, Code128 subsets A.B.C, Codabar, Standard 2 of 5, Industrial 2 of 5, Interleave 2 of 5, EAN-8, EAN-13, EAN-14, EAN-128, ITF14, UPC-A, UPC-E, EAN and UPC 2(5) digits add-on, MSI, PLESSEY, PLANET, POSTNET, RSS-Stacked, GS1 DataBar, China Post, Telepen, LOGMARS	CODABLOCK F mode, DataMatrix, Maxicode, Micro PDF-417, Aztec, MicroPDF417, QR code, RSS Barcode (GS1 Databar)
1D bar code	2D bar code				
Code 11, Code 39, Code 49, Code 93, Code128UCC, Code128 subsets A.B.C, Codabar, Standard 2 of 5, Industrial 2 of 5, Interleave 2 of 5, EAN-8, EAN-13, EAN-14, EAN-128, ITF14, UPC-A, UPC-E, EAN and UPC 2(5) digits add-on, MSI, PLESSEY, PLANET, POSTNET, RSS-Stacked, GS1 DataBar, China Post, Telepen, LOGMARS	CODABLOCK F mode, DataMatrix, Maxicode, Micro PDF-417, Aztec, MicroPDF417, QR code, RSS Barcode (GS1 Databar)				
Font & bar code rotation	0, 90, 180, 270 degree				
Command set	TSPL-EZD				
Others	<ul style="list-style-type: none"> ▪ Standard for real time clock ▪ Standard for buzzer ▪ Print head pressure force & pressure location adjustable ▪ Heater element damage detection ▪ Clean print head warning 				

1.2.2 Optional Features

The print engine offers the following optional features.

Option feature	Dealer option
Internal Bluetooth 4.0 module	<input type="radio"/>
Wi-Fi module a/b/g/n band	<input type="radio"/>

1.3 Print Engine Specifications

Print Engine Specifications	
Physical dimensions	W:245mm x H:300mm x L:390mm
Weight	Net weight:13kg Gross weight:16kg
Power	Auto switching power supply (20% print ratio) • Input: AC 100-240V, 4-2A, 50-60Hz • Output: DC 5V, 5A; DC 24V, 7A; DC 36V, 1.4A; Total 243W Note: ▪ The max. full web black bar is limited to 5 mm only, otherwise print engine may stop printing to protect power supply. ▪ Default delay time to power saver mode for standard model is 60 minutes.
Environmental condition	Operation: 5 ~ 40 °C (41 ~ 104 °F), 25~85% non-condensing Storage: -40 ~ 60 °C (-40 ~ 140 °F), 10~90% non-condensing

1.4 Print Specifications

Print Specifications	PEX-1120 PEX-1220	PEX-1130 PEX-1230	PEX-1160 PEX-1260
Print head resolution (dots per inch/mm)	203 dots/inch (8 dots/mm)	300 dots/inch (12 dots/mm)	600 dots/inch (24 dots/mm)
Printing method	Thermal transfer/ or direct thermal		
Dot size (width x length)	0.125 x 0.125 mm (1 mm = 8 dots)	0.084 x 0.084 mm (1 mm = 12 dots)	0.042 x 0.042 mm (1 mm = 24 dots)
Print speed (inches per second)	2,3,4,5... 18 ips selectable	2,3,4,5... 14 ips selectable	1.5,2,3.... 6 ips selectable
	Up to 18 IPS	Up to 14 IPS	Up to 6 IPS
Max. print width	4.09" (104 mm)		
Max. print length	1000" (25400 mm)	450" (11430 mm)	100" (2540 mm)
Printout bias	Vertical: 0.3 ~ 1 mm max. Horizontal: 1 mm max.		

2.3 Ribbon Specifications

Ribbon Specifications	
Ribbon outside diameter	Max. 90 OD
Ribbon length	600 meter
Ribbon core inside diameter	1" (25.4 mm)
Ribbon width	25.4 mm ~ 114.3 mm (1"~4.5")
Ribbon wound type	Ink coated outside wound, ink coated inside wound
Ribbon end type	Transparency

2.3 Media Specifications

Media Specifications	
Media type	Continuous, die-cut, black mark, external fan-fold, notch
Media width	20 mm ~ 114 mm (0.78" ~ 4.49")
Media thickness	0.076 mm ~ 0.305 mm (2.99 ~ 12.01 mil)
Label length	5 mm ~
Label length (peeler mode)	Factory option of media sensor for 5mm~152mm (Gap sensor only, with fixed position of the sensor). System integrator need to notice the design of Take Label Sensor to fit the label position of the small size of the labels. Please contact TSC service.
Black mark	Min. 8 mm (W) x Min. 2 mm (H)
Gap height	Min. 2 mm

2. Operations Overview

2.1 Unpacking and Inspection

This print engine has been specially packaged to withstand damage during shipping. Please carefully inspect the packaging and print engine upon receiving the bar code print engine. Please retain the packaging materials in case you need to reship the print engine. Unpacking the print engine, the following items are included in the carton.

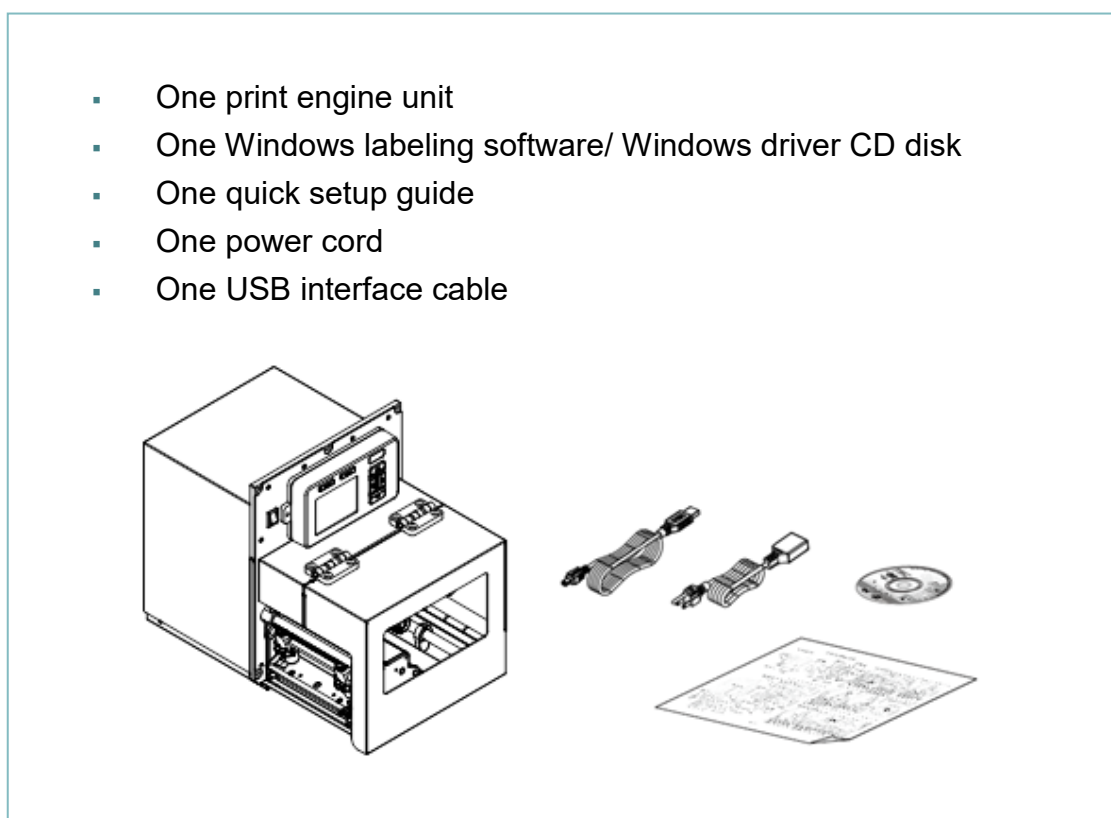

If any parts are missing, please contact the Customer Service Department of your purchased reseller or distributor.

Note: Check the production date

Serial NO.: XXX 18 12 XXXX

YEAR
Год

WEEK
Неделю

2.2 Print Engine Orientation

The PEX-1000 series are available in a left-hand configuration and a right-hand configuration.

**PEX-1120/ PEX-1130/ PEX-1160 series
Left-hand model**

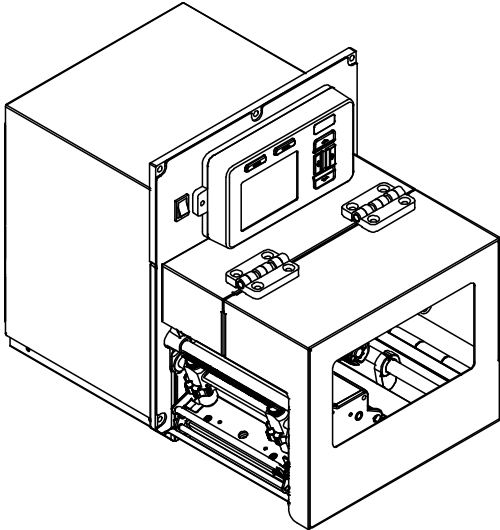

**PEX-1220/ PEX-1230/ PEX-1260 series
Right-hand model**

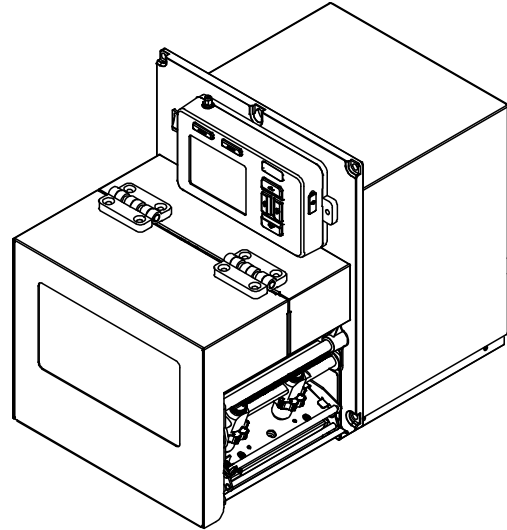

Note:

This document is going to show the components inside the media compartment of a left-hand print engine. A right-hand unit contains a mirror image of those components.

Familiarize yourself with those components before continuing with the print engine setup procedure.

2.3 Checking the Installation Space

Please check the space for mounting the print engine into an applicator. Please refer to the dimensions in this section.

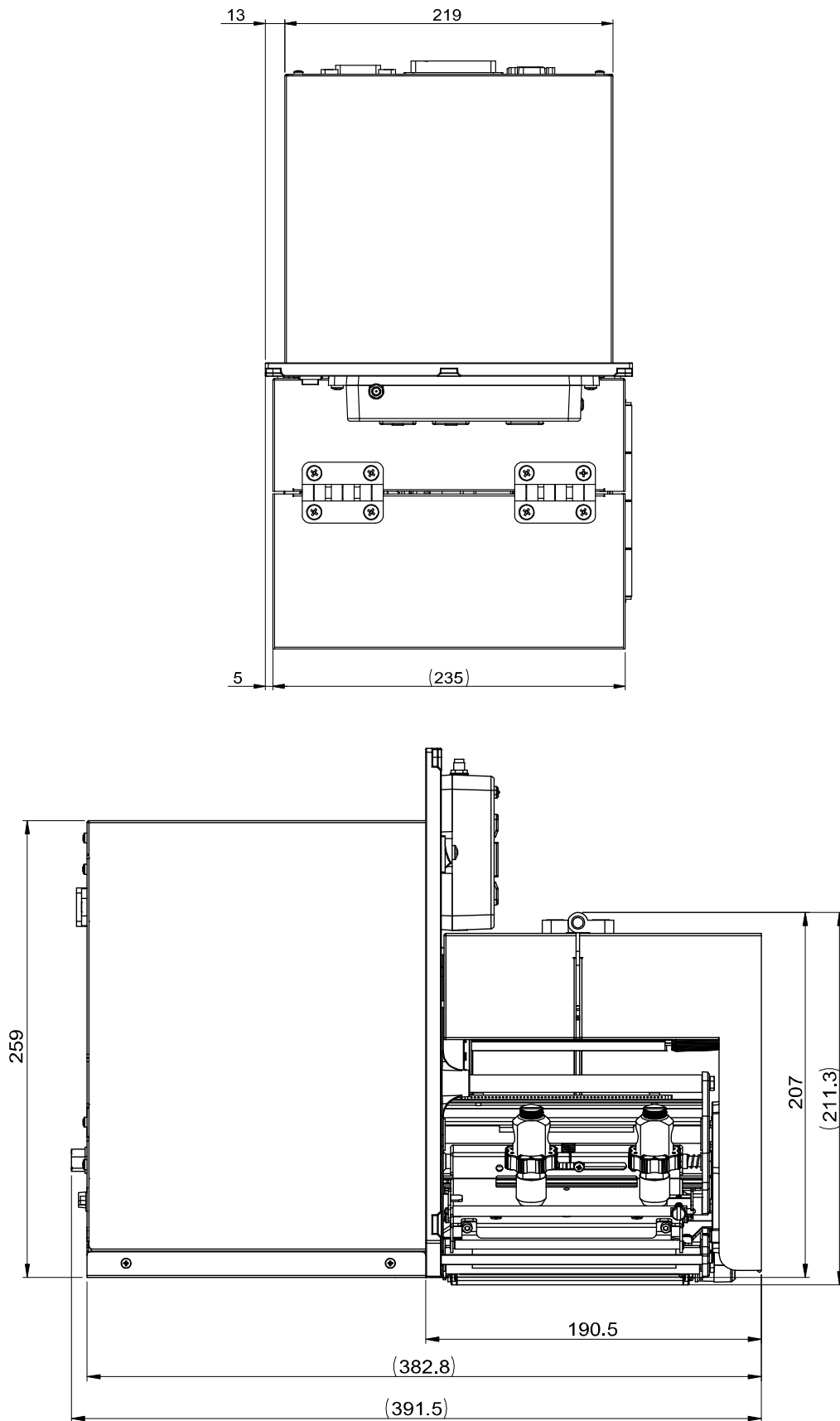

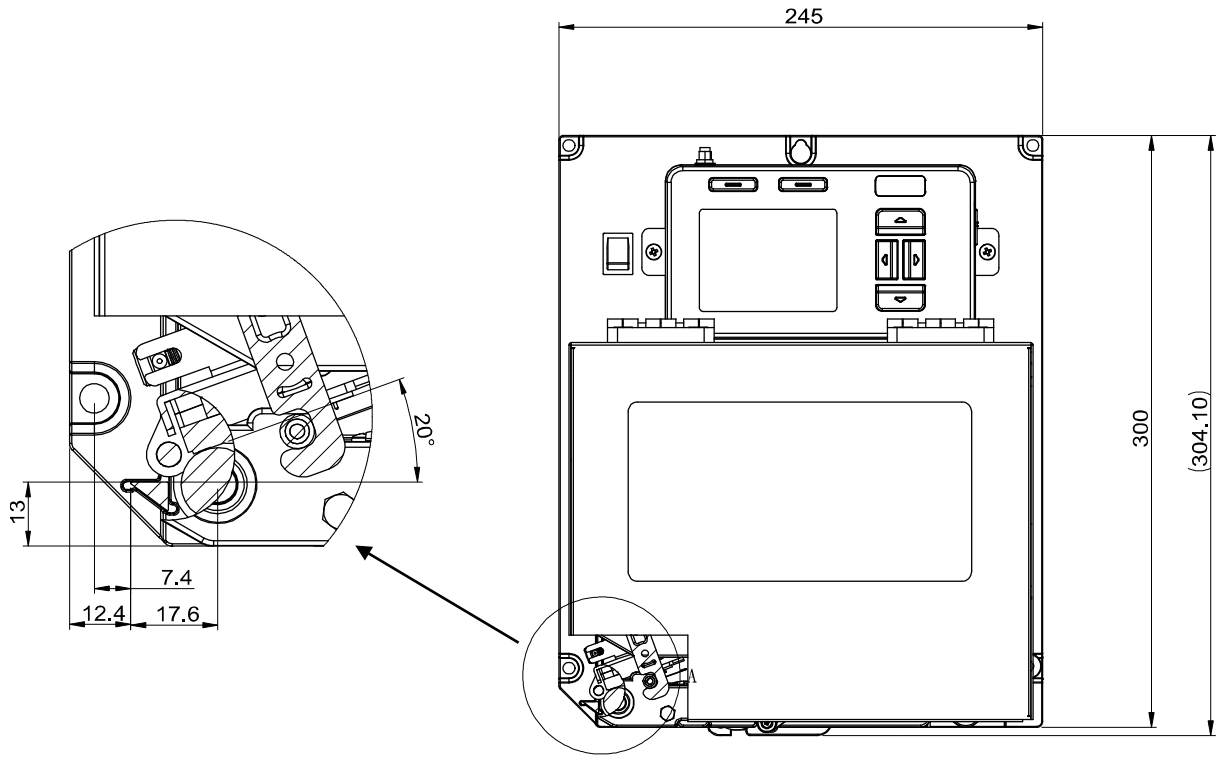

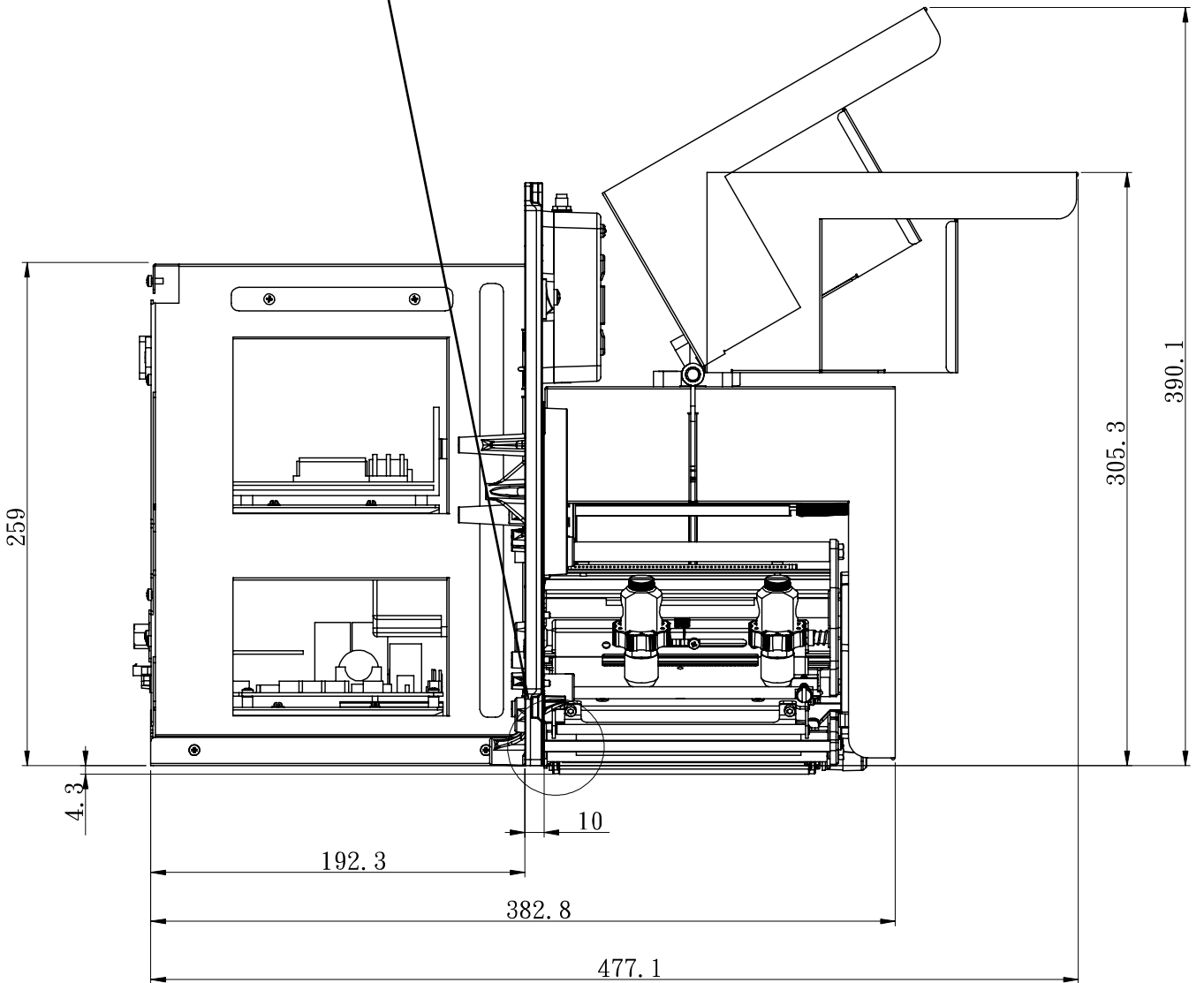
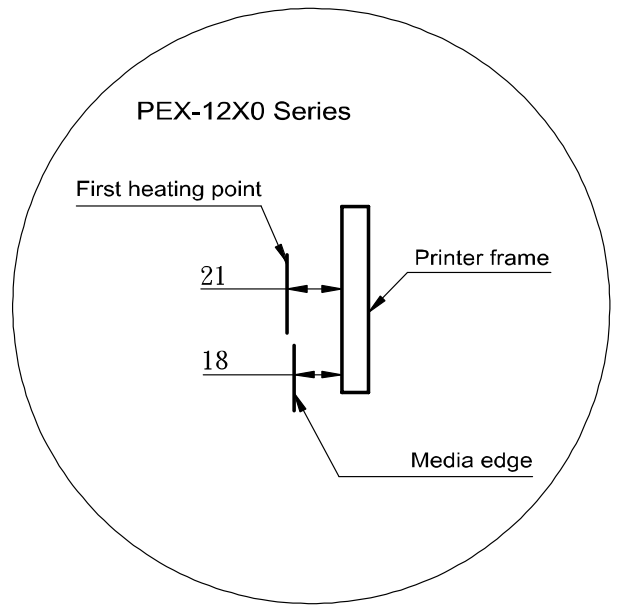
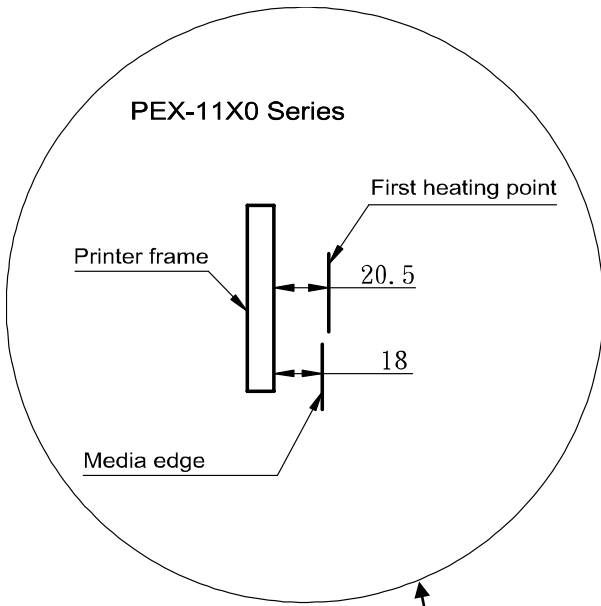

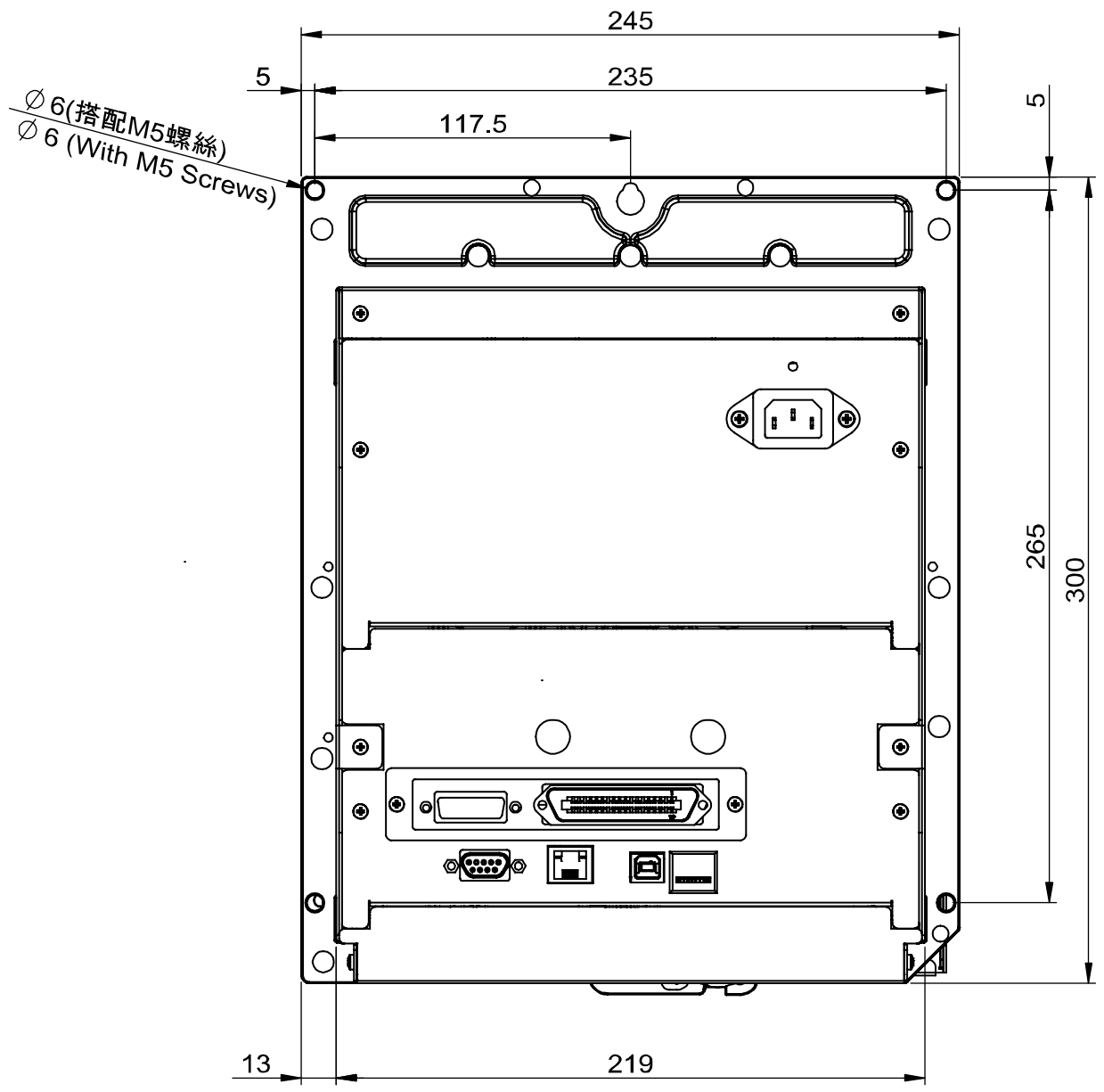

2.4 Print Engine Overview

2.4.1 Front View



2.4.2 Interior view

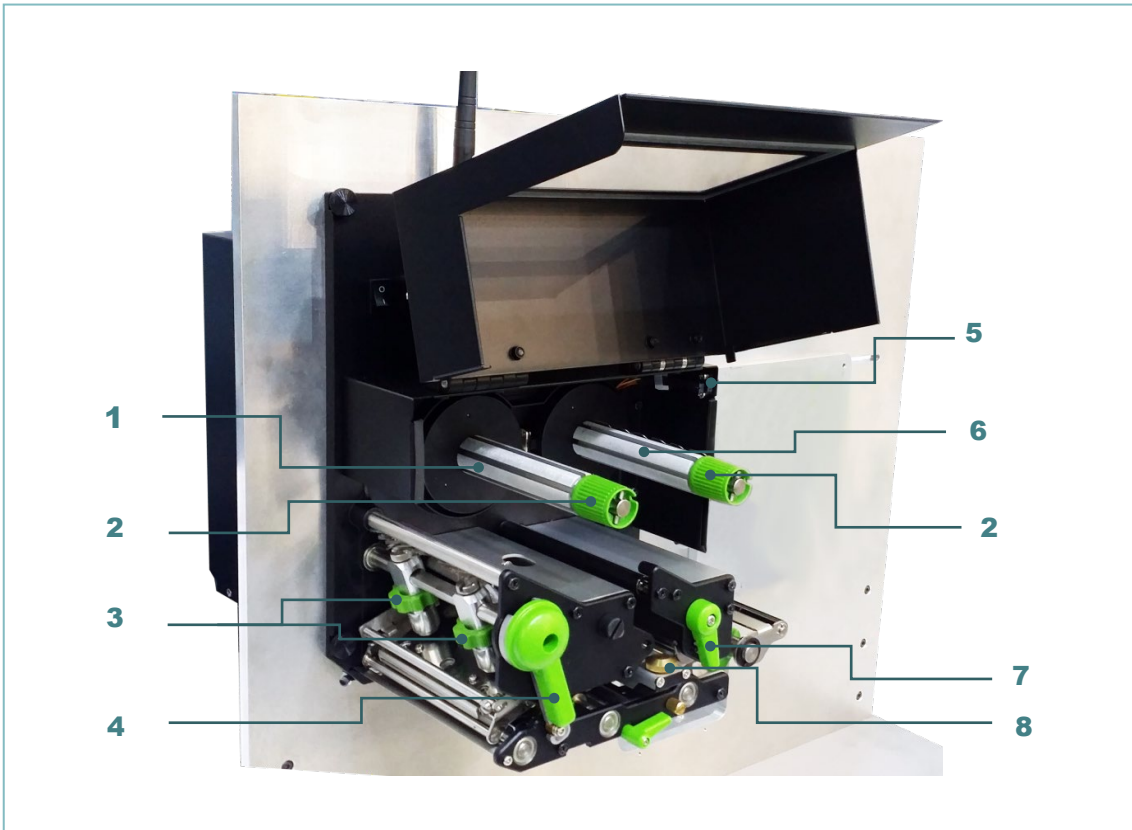

1. Ribbon rewind spindle
2. Ribbon tension adjustment knobs
3. Print head pressure adjustment knobs
4. Print head release lever
5. Print engine cover open sensor
6. Ribbon supply spindle
7. Label guide bar release lever
8. Media sensor position adjustment knob
9. Platen roller
10. Print head
11. Media sensor
12. Label guide

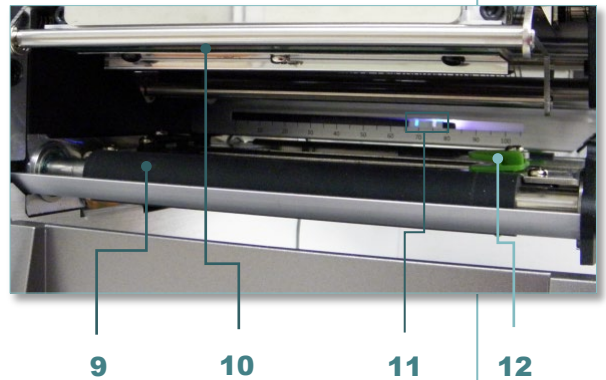

2.4.3 Rear View

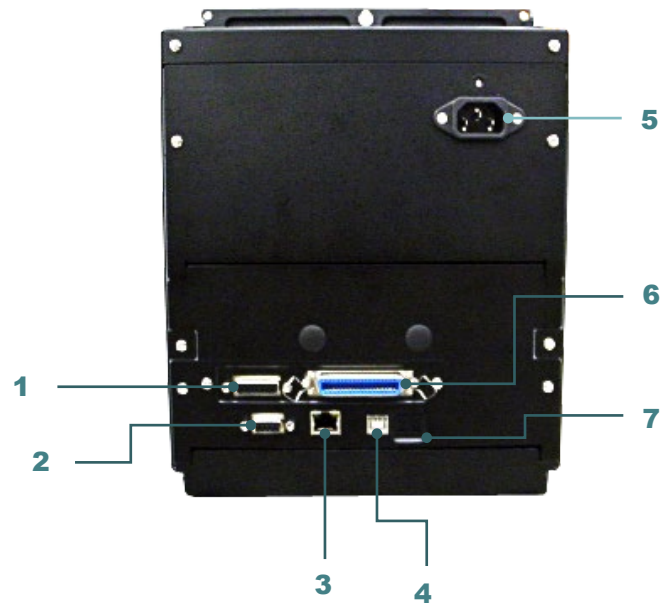

1. GPIO interface (Applicator interface with DB15F connector +5V I/O)
2. RS-232C interface
3. Ethernet interface
4. USB interface
5. Power cord socket
6. Centronics interface
7. * Micro SD card socket

Note:
The interface picture here is for reference only. Please refer to the product specification for the interfaces availability.

* Recommended SD card specification

Type	SD card spec	SD card capacity	Approved SD card manufacturer
Micro SD	V2.0 Class 4	4G	Transcend
	V2.0 Class 4	8G	Transcend
	V3.0 Class 10 UHS-I	16G	Transcend
	V3.0 Class 10 UHS-I	32G	Transcend
	V3.0 Class 10	16G	Kingston
	V2.0 Class 4	16G	Scandisk
	V3.0 Class 10 UHS-I	16G	Scandisk

- The DOS FAT file system is supported for the SD card.
- Folders/files stored in the SD card should be in the 8.3 filename format.
- The miniSD/microSD card to SD card slot adapter is required.

2.5 Operator Control

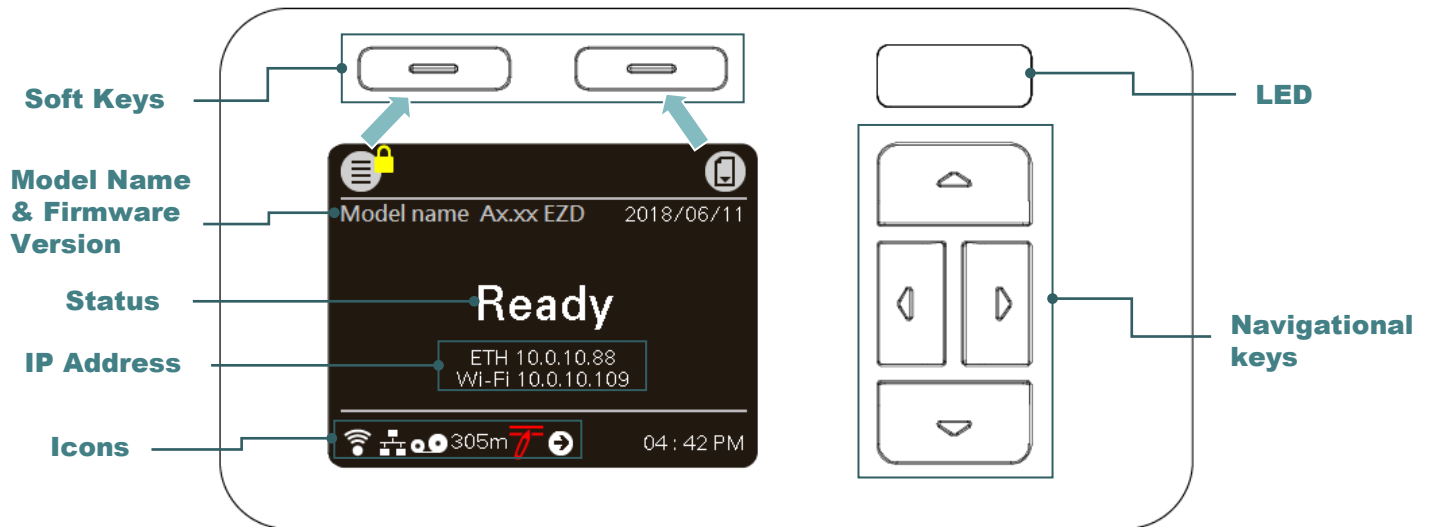

2.5.1 LED Indication







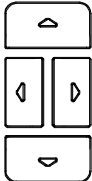



This print engine has one three-color LED indicator.

LED Color / Status	Description
Green/ Solid	This illuminates that the power is on and the device is ready to use.
Green/ Flash	This illuminates that the system is downloading data from PC to memory or the print engine is paused.
Amber	This illuminates that the system is clearing data from print engine.
Red / Solid	This illuminates print head open.
Red / Flash	This illuminates a printing error, such as paper empty, paper jam, or memory error etc.

2.5.2 Keys

Keys	Function
Soft keys 	The labels on the header of the UI will explain the function for left and right soft key. Check the labels on the header of the UI screen. The meaning of the soft keys will vary.
Navigational keys 	Used to select items, menu selection, and navigation in the UI.

2.5.2 Main page Icons

Indicated icon	Indication
	Wi-Fi device is ready
	Ethernet is connected
	Bluetooth device is ready
	Remaining amount of ribbon(m)
	Pending documents in the printer
	Security lock
	Print head cleaning notice
	Print engine cover open
Icon button	Function
	Enter the Menu or the “Favorites” option
	Enter cursor (be marked in green) located option
	Feed button (advance one label)

3. Setup

3.1 Setting up the print engine

1. Please refer to the section 2.3 to install the print engine to an applicator.
2. Make sure the power switch is off.
3. Connect the print engine to the computer with the provided USB cable or available connections.
4. Plug the power cord into the AC power cord socket at the rear of the print engine, and then plug the power cord into a properly grounded power outlet.

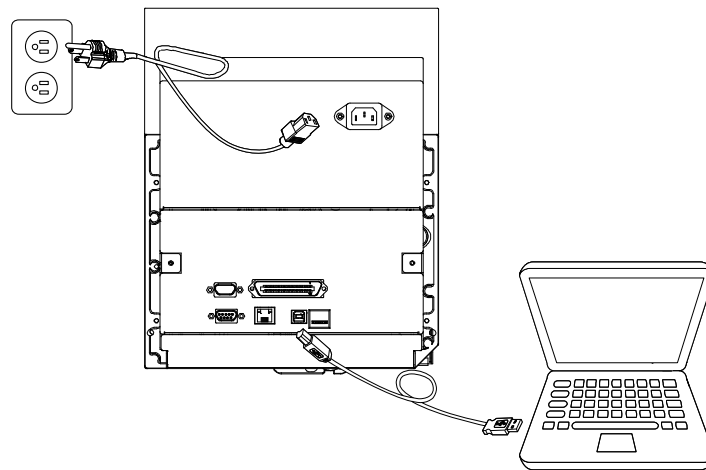

Note: Please switch OFF power switch prior to plug in the power cord to power jack.

3.2 Loading the Ribbon

1. Open the print engine cover.

Note: There is no media supply spindle for standard model.

Left-hand model

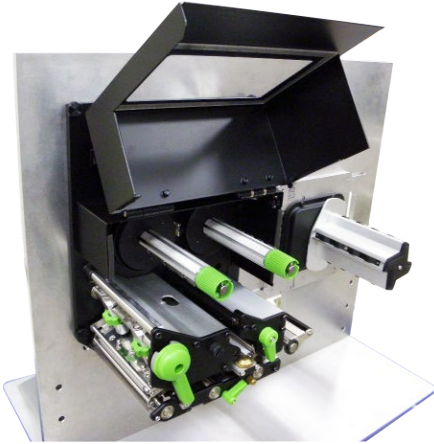

Right-hand model

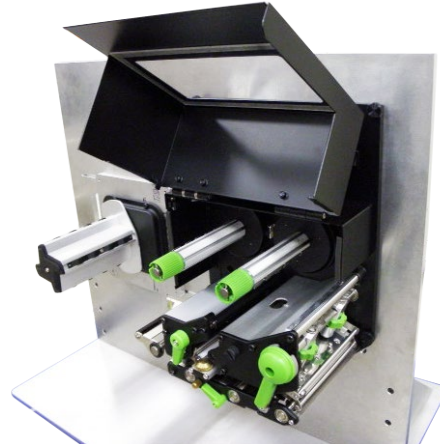

2. Install the ribbon and paper core onto ribbon supply spindle and ribbon rewind spindle.

Left-hand model



Right-hand model

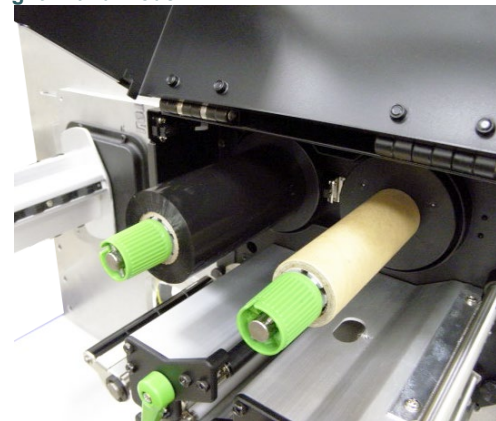

3. Push print head release lever to open print head mechanism.

Left-hand model

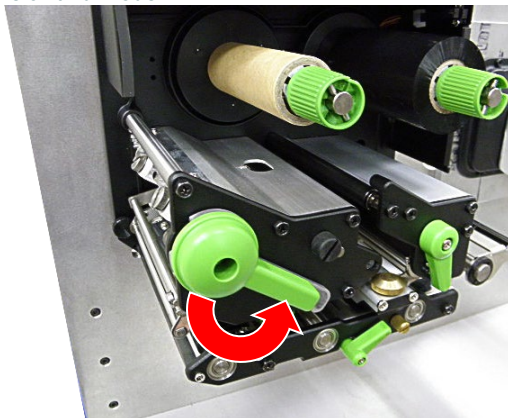

Right-hand model

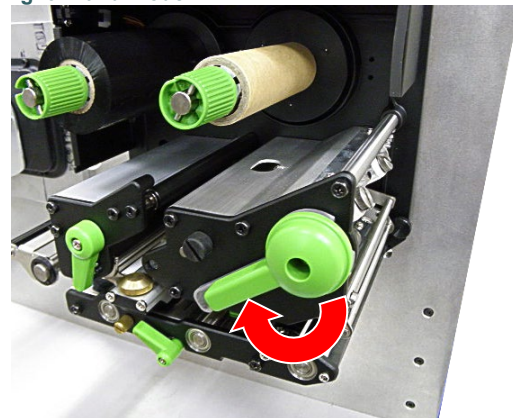

-
4. Thread ribbon above the ribbon guide bar and through ribbon sensor slot. (Please refer to "Loading path for ribbon" as following fig.)

Left-hand model

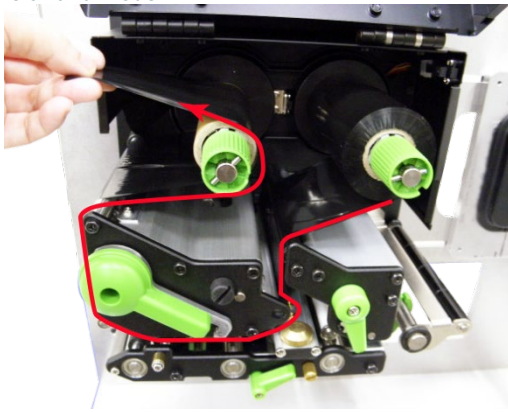

Right-hand model

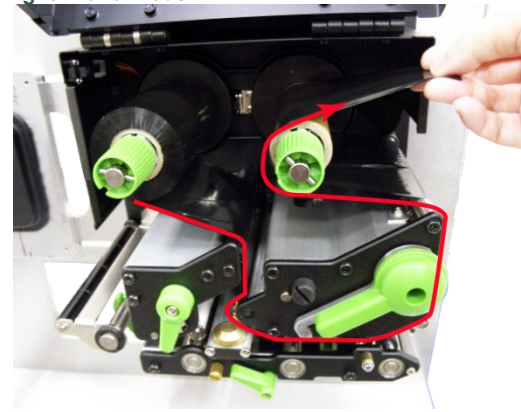

5. Wind the ribbon rewind spindle counterclockwise roughly 3~5 circles until ribbon is smooth, properly stretched and wrinkle-free.

Left-hand model

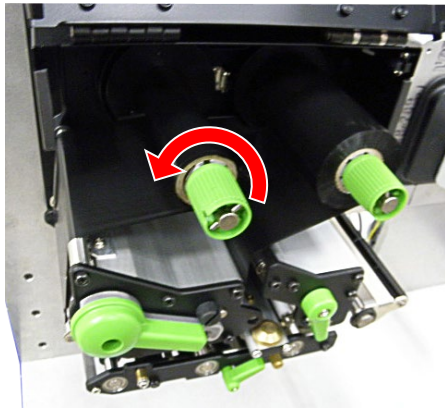

Right-hand model

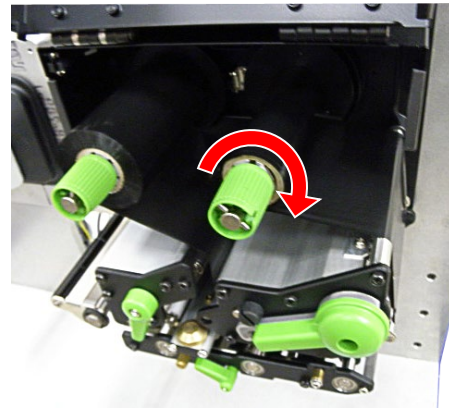

6. Close the print head mechanism by pushing the print head release lever.

Left-hand model

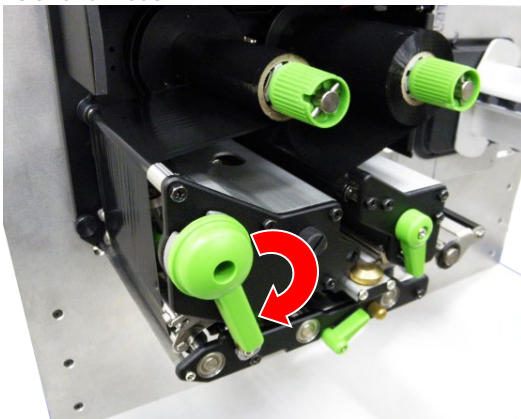

Right-hand model

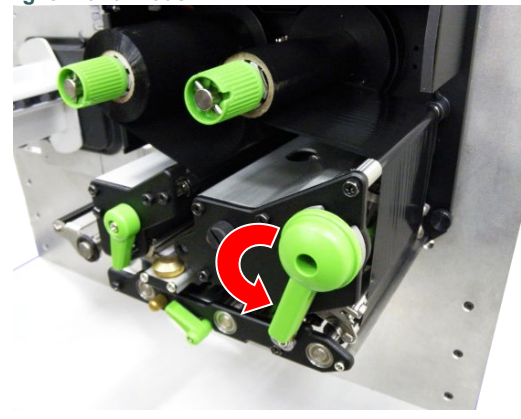

Note:
Please refer to video on [TSC YouTube](#).

Loading path for ribbon

Left-hand model

* Ink coated outside wound

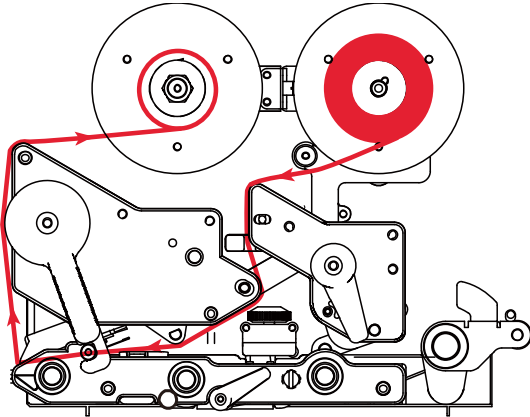

* Ink coated inside wound

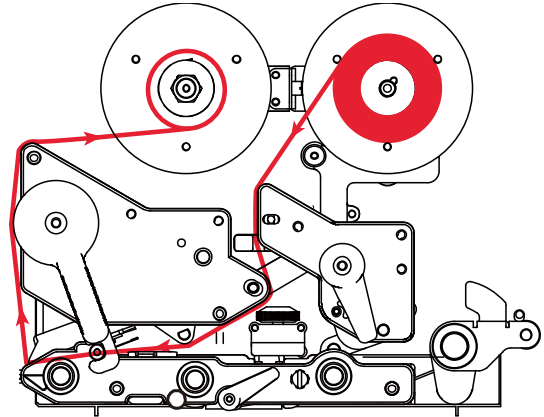

Right-hand model

* Ink coated outside wound

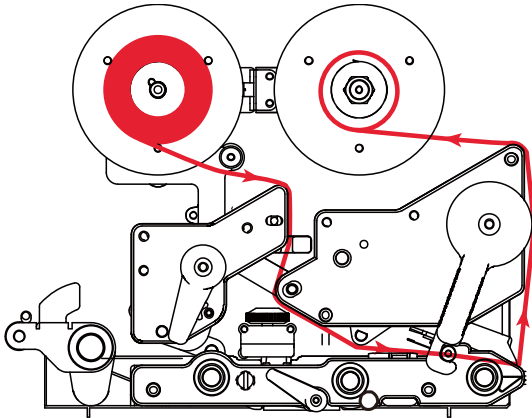

* Ink coated inside wound

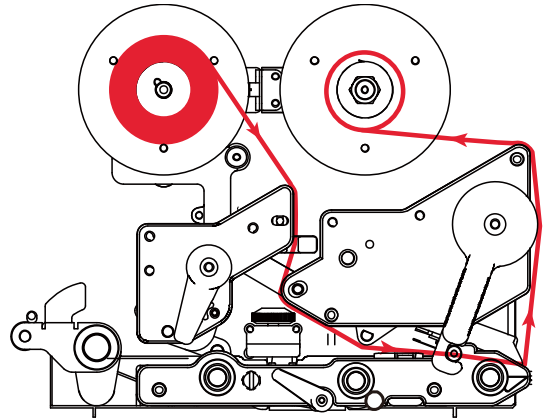

3.3 Loading the Media

3.3.1 Loading the Media

1. Open the print engine cover.
Note: There is no media supply spindle for standard model.

Left-hand model

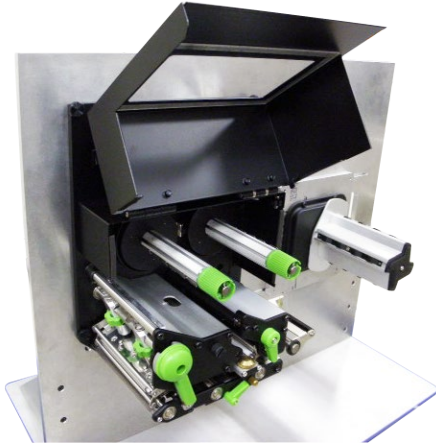

Right-hand model

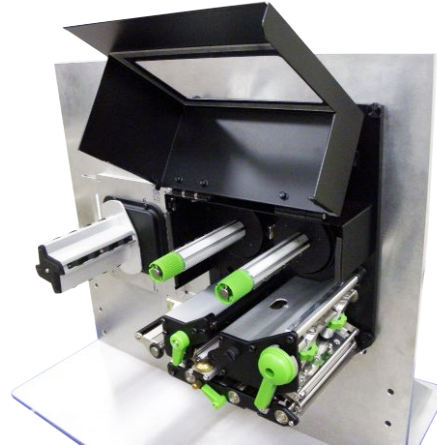

2. Push open the print head release lever and label guide bar release lever for loading media.

Left-hand model

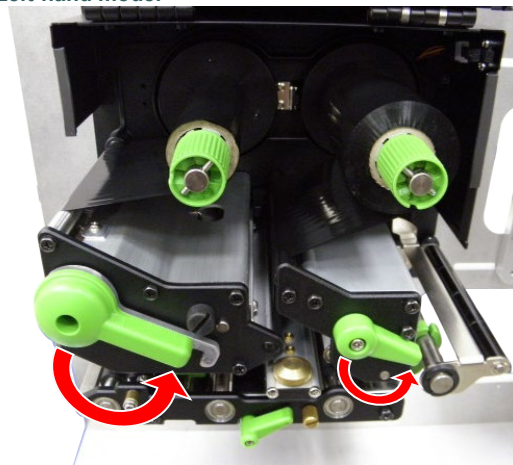

Right-hand model

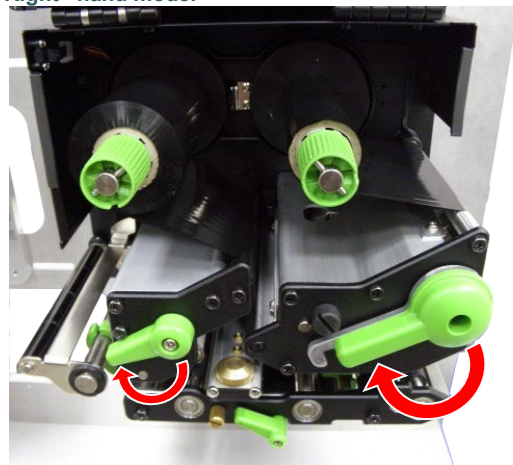

3. Pull the leading edge of the label forward through the media guide bar pass media sensor, and place the leading edge onto the platen roller.

Left-hand model



Right-hand model

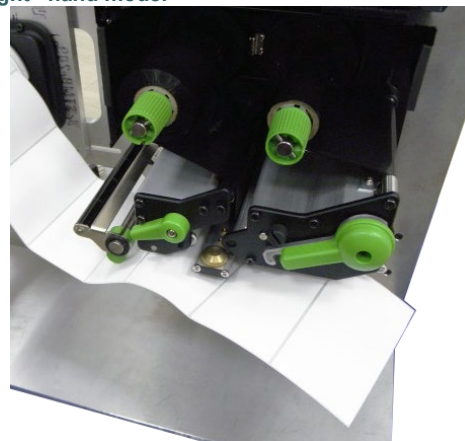

-
4. Adjust the rear label guide (green) to fit the label width.

Left-hand model

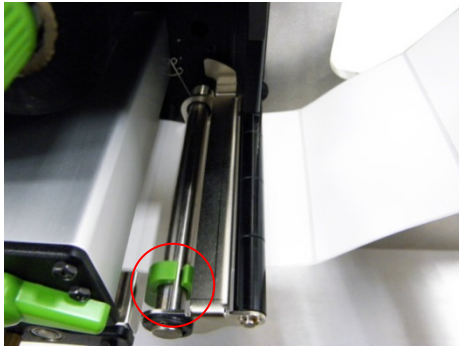

Right-hand model

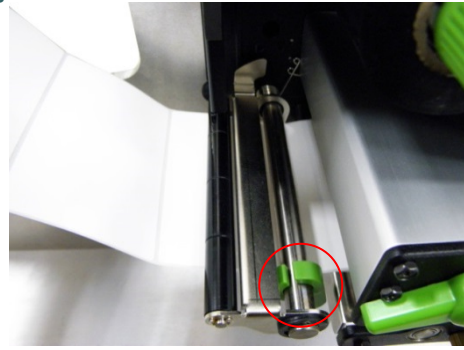

-
5. Adjust the front label guide (green) to fit the label width.

Left-hand model



Right-hand model



-
6. Move the media sensor by adjusting the media sensor position adjustment knob, make sure the gap or black mark sensor is at the location where media gap/black mark will pass through for sensing.

Left-hand model



Black mark (Blue) GAP (White)

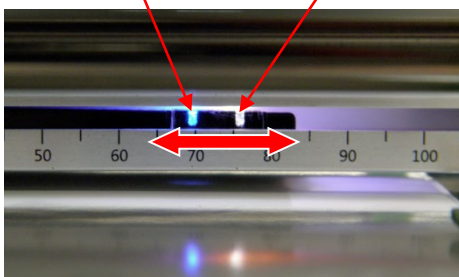

Right-hand model

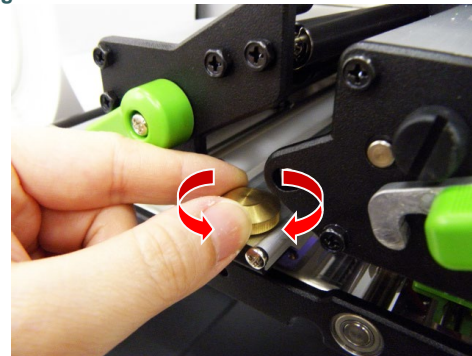

GAP (White) Black mark (Blue)

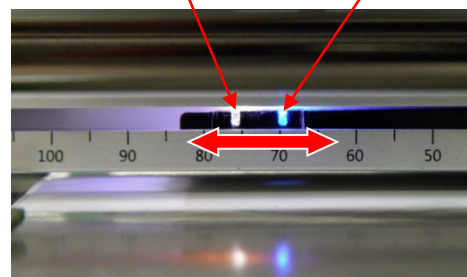

7. Close print head release lever and label guide bar release lever.
8. Set media sensor type and calibrate the selected sensor.

Left-hand model

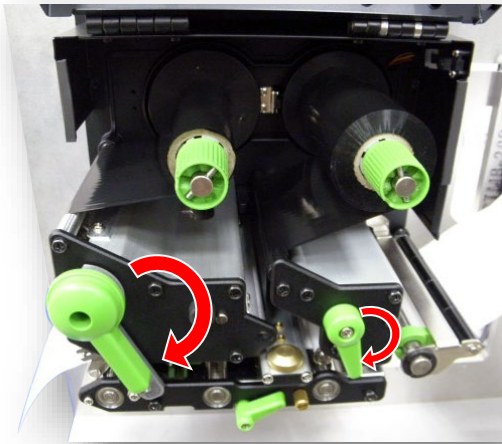

Right-hand model

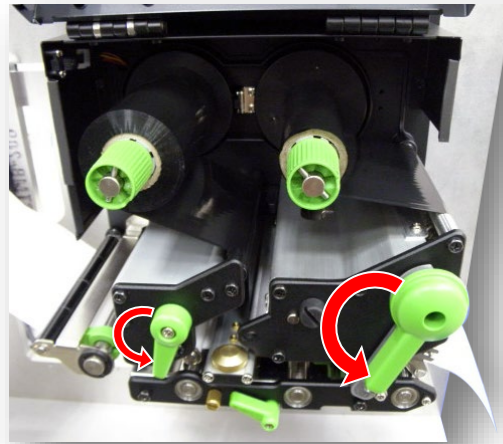

Note:

- * Please calibrate the gap/black mark sensor when changing media.
- * Please refer to video on [TSC YouTube](#).

Loading path for media

Left-hand model

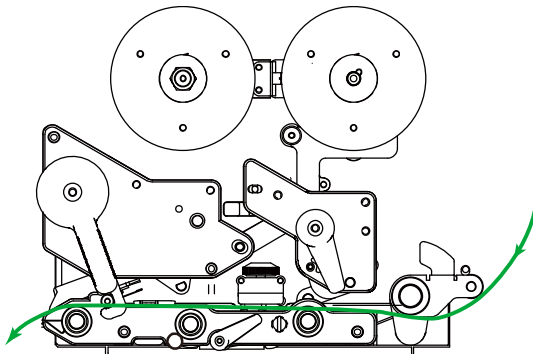

Right-hand model

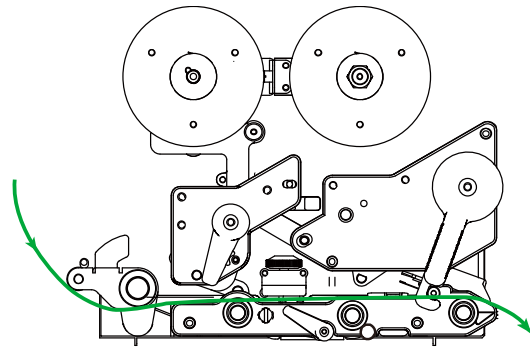

3.3.2 Loading Media in Peel-off Mode

1. Open the print engine cover.
2. Please refer to section 3.3.1 step 3~8 for loading media.

Note:

- * Please calibrate the gap/black mark sensor before loading media in peel-off mode to avoid paper jam.
 - * There are no peel-off sensor and liner rewind spindle for standard model.
-

3. Open print head release lever and label guide bar release lever to pull approximately 650mm of label through the front of the print engine.
4. Remove several labels to leave liner.

Left-hand model

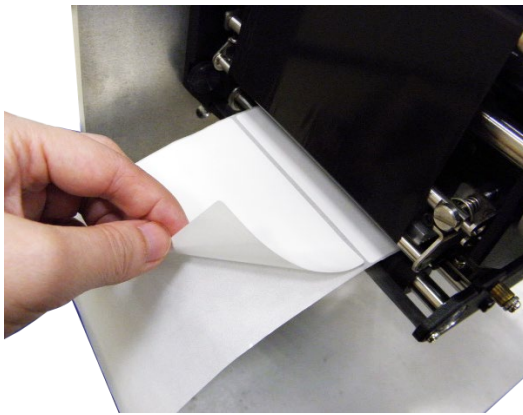

Right-hand model

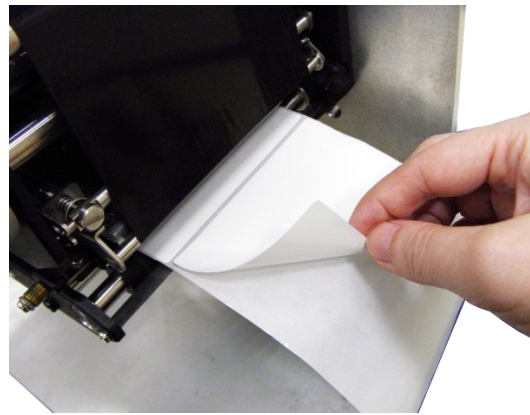

5. Open the peel-off roller release lever.

Left-hand model



Right-hand model



-
6. Feed the leading edge of liner through the peel-off roller.

Left-hand model

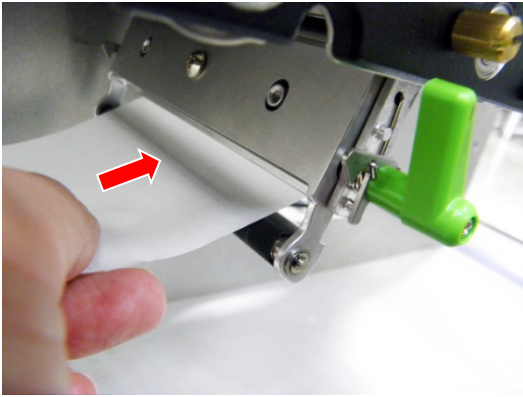

Right-hand model

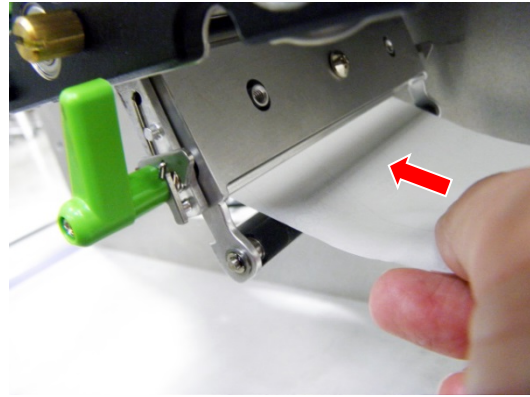

-
7. Press the middle of the peel-off roller to close the peel-off roller release lever.

Left-hand model

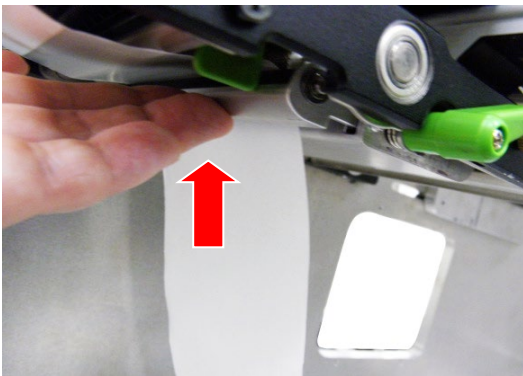

Right-hand model

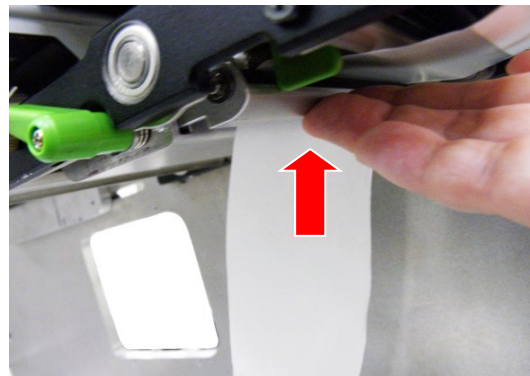

-
8. Close print head release lever and label guide bar release lever.

Left-hand model

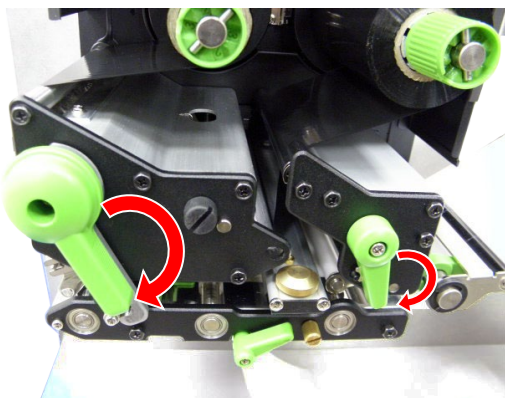

Right-hand model

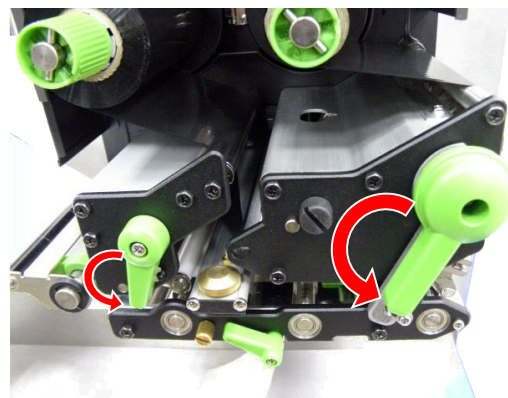

9. Press the FEED button to test.

Left-hand model



Right-hand model

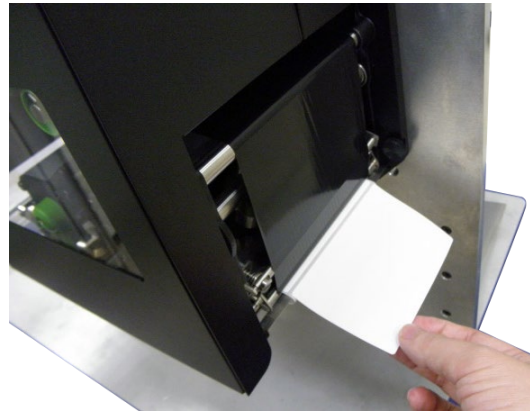

Loading path for media in peel-off mode

Left-hand model

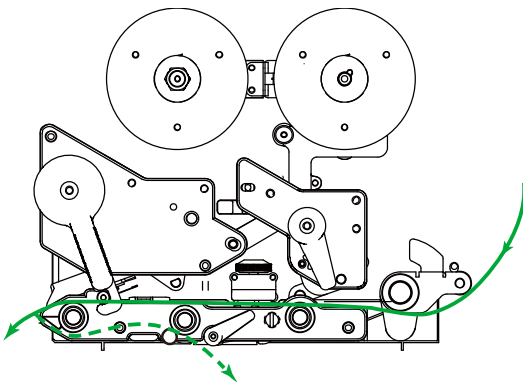

Right-hand model

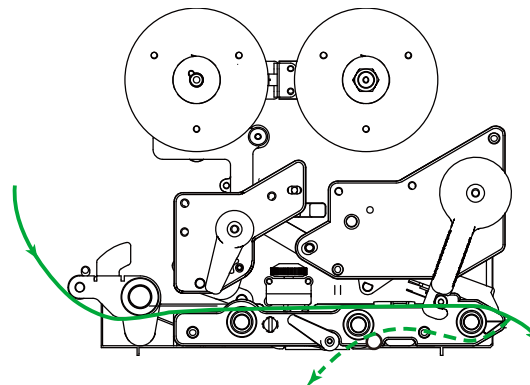

4. Moveable Print Head Pressure Adjustment Knob

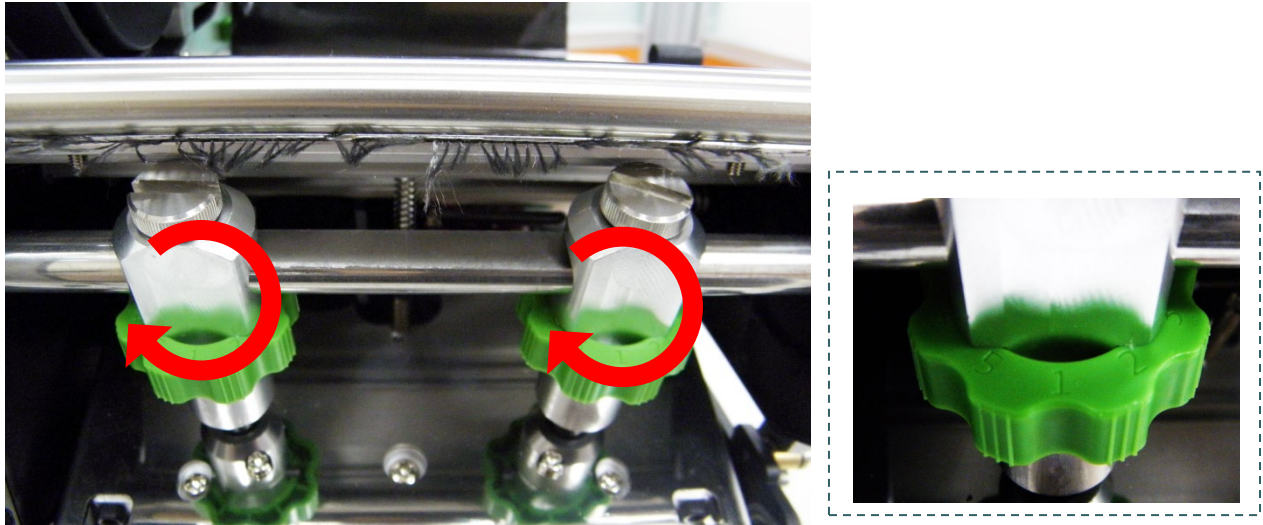

The moveable print head pressure adjustment knob has 5 levels of adjustment. Because the print engine's paper alignment is to the left side (or right side/ PEX-1200 series) of mechanism, different media widths require different pressure to print correctly. Therefore it may require to adjust the pressure knob to get your best print quality. For example, if the label width is 4", adjust both print head pressure adjustment knobs to the same level. If the label is less than 2" wide with PEX-1100 series, increase the left side print head pressure by rotating the adjustment knob clockwise and decrease the right side pressure by rotating the adjustment knob counter-clockwise to level 1.

4.1 Mechanism Fine Adjustment to Avoid Ribbon Wrinkles

This print engine has been fully tested before delivery. There should be no ribbon wrinkle presented on the media for general-purpose printing application. Ribbon wrinkle is related to the media thickness, print head pressure balance, ribbon film characteristics, print darkness setting...etc. In case the ribbon wrinkle happens, please follow the instructions below to adjust the print engine parts.

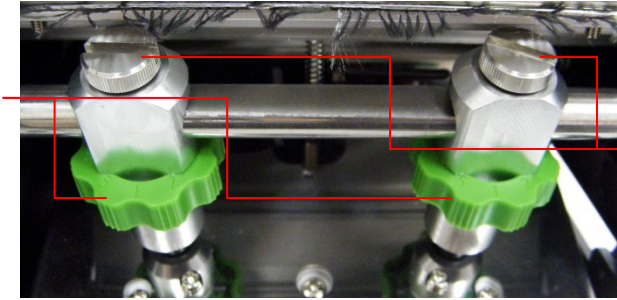
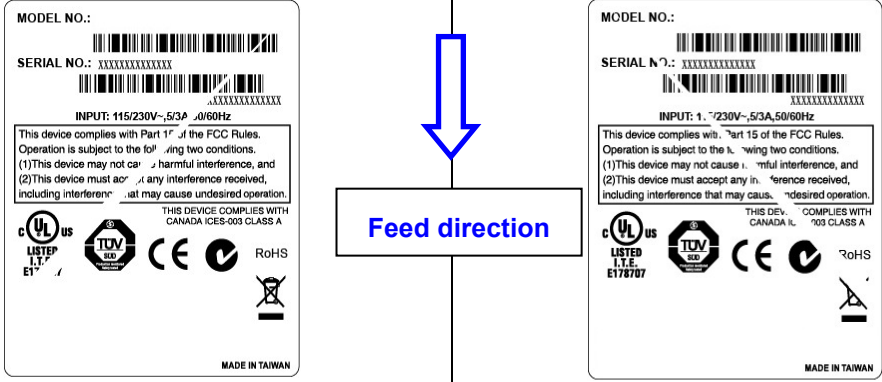
<p>Adjustable Print Parts</p>	<p>The print head pressure adjustment knob has 5 levels of settings. Clockwise direction adjustment is to increase the print head pressure. Counter Clockwise adjustment can decrease the print head pressure.</p> 	
<p>Symptom</p>	<p>1. Wrinkle happens from label lower left to upper right direction (" / ")</p>	<p>2. Wrinkle happens from label lower right to upper left direction (" \ ")</p>
<p>Wrinkle Example</p>	 <p>If the wrinkle on the label starts from the lower left side to upper right side, please do following adjustment.</p> <ol style="list-style-type: none"> 1. Decrease the right side print head pressure adjustment knob setting 1 level per each adjustment then print the label again to check if wrinkle is gone. 2. If the right side print head adjustment knob setting has been set to index 1 (the lowest pressure index), please increase the left side print head pressure. <p>If the wrinkle on the label starts from the lower right side to upper left side, please do following adjustment.</p> <ol style="list-style-type: none"> 1. Decrease the left side print head pressure adjustment knob setting 1 level per each adjustment then print the label again to check if wrinkle is gone. 2. If the left side print head adjustment knob level has been set to index 1 (the lowest index), please increase the right side print head pressure. 	

5. Ribbon Tension Adjustment Knob

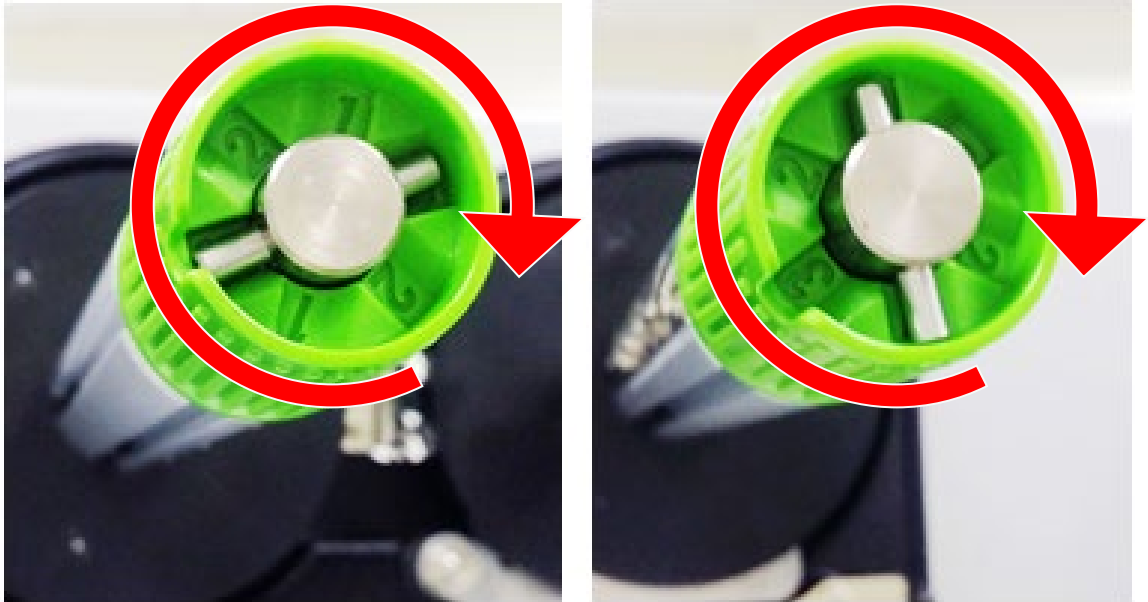

The ribbon tension adjustment knob has 3 levels of adjustment. Because the print engine's ribbon alignment is to the left side (or right side/ PEX-1200 series) of mechanism, different ribbon width require different tension to print correctly. Therefore it may require to adjust the ribbon tension knob to get your best print quality. The biggest tension is #1. Adjust the tension by turning the knobs to suitable # (1, 2 or3) on both ribbon supply & rewind spindles, suggest the tension # to be the same on both spindles. Factory default tension is #1.

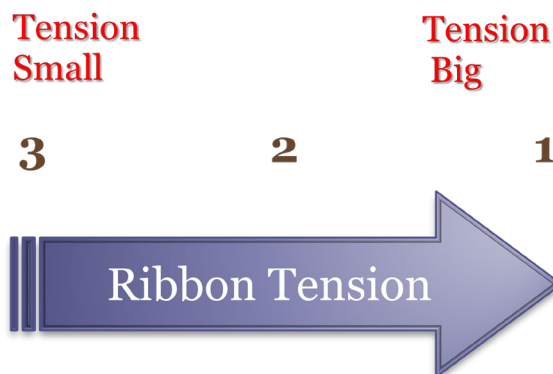

2.3 Suggestion of Ribbon Tension Adjustment

For 4" width ribbon

If the ribbon width is 4", adjust both ribbon tension adjustment knobs to the #1 on ribbon supply & rewind spindles. (Factory default tension is #1)

**Ribbon Rewind Spindle
Tension # 1**



**Ribbon Supply Spindle
Tension # 1**



For 3" width ribbon

If the ribbon width is 3", adjust both ribbon tension adjustment knobs to the #2 on ribbon supply & rewind spindles.

**Ribbon Rewind Spindle
Tension # 2**



**Ribbon Supply Spindle
Tension # 2**



For 2" width ribbon

If the ribbon width is 2", adjust both ribbon tension adjustment knobs to the #3 on ribbon supply & rewind spindles.

**Ribbon Rewind Spindle
Tension # 3**



**Ribbon Supply Spindle
Tension # 3**



6. Diagnostic Tool

TSC's Diagnostic Utility is an integrated tool incorporating features that enable you to explore a print engine's settings/status; change a print engine's settings; download graphics, fonts and firmware; create a print bitmap font; and send additional commands to a print engine. With the aid of this powerful tool, you can review print engine status and setting in an instant, which makes it much easier to troubleshoot problems and other issues.

6.1 Start the Diagnostic Tool

1. Double click on the Diagnostic tool icon  `DiagTool.exe` to start the software.
2. There are four features (Printer Configuration, File Manager, Bitmap Font Manager, Command Tool) included in the Diagnostic utility.

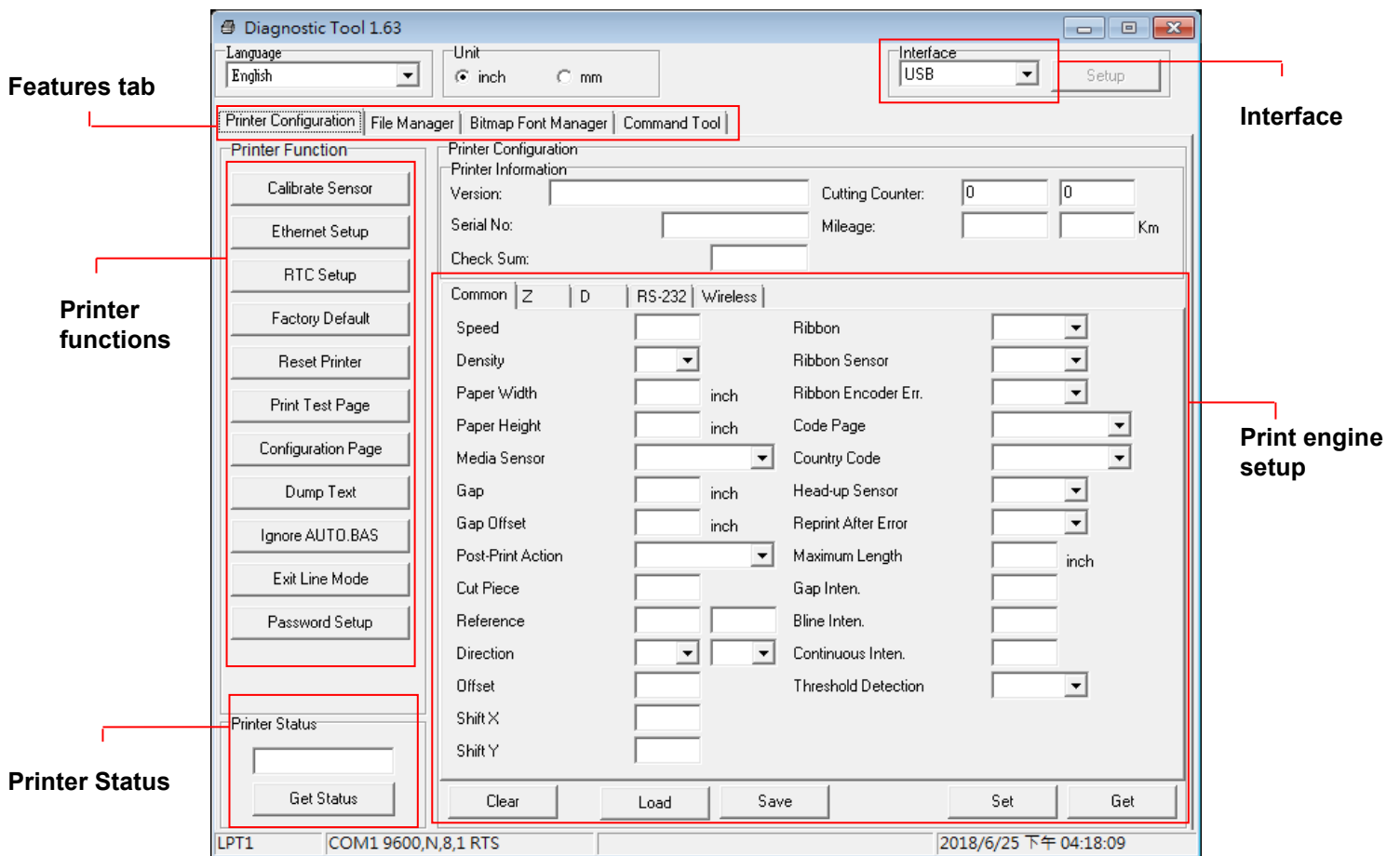

6.2 Function

1. Connect the print engine and computer with a cable.
2. Select the PC interface connected with bar code print engine.

USB cable	Other cable
Interface USB <input type="button" value="Setup"/> <p>The default interface setting is USB interface. If USB interface is connected with print engine, no other settings need to be changed in the interface field.</p>	Interface COM <input type="button" value="Setup 2"/> <ul style="list-style-type: none"> USB COM 1 LPT ETHERNET

3. Click the “Printer Function” button to setup.
4. The detail functions in the Printer Function Group are listed as below.

Printer Function	Function	Description
<input type="button" value="Calibrate Sensor"/>	Calibrate Sensor	Calibrate the sensor specified in the Print engine Setup group media sensor field
<input type="button" value="Ethernet Setup"/>	Ethernet Setup	Setup the IP address, subnet mask, gateway for the on board Ethernet
<input type="button" value="RTC Setup"/>	RTC Setup	Synchronize print engine Real Time Clock with PC
<input type="button" value="Factory Default"/>	Factory Default	Initialize the print engine and restore the settings to factory default.
<input type="button" value="Reset Printer"/>	Reset Printer	Reboot print engine
<input type="button" value="Print Test Page"/>	Print Test Page	Print a test page
<input type="button" value="Configuration Page"/>	Configuration Page	Print configuration
<input type="button" value="Dump Text"/>	Dump Text	To activate dump mode
<input type="button" value="Ignore AUTO.BAS"/>	Ignore AUTO.BAS	Ignore the downloaded AUTO.BAS program
<input type="button" value="Exit Line Mode"/>	Exit Line Mode	Exit line mode.
<input type="button" value="Password Setup"/>	Password Setup	Set the password to protect the settings

For more information about Diagnostic Tool, please refer to the diagnostic utility quick start guide in the CD disk \ Utilities directory.

2.3 Setting Ethernet by Diagnostic Tool

The Diagnostic Utility is enclosed in the CD disk \Utilities directory. Users can use Diagnostic Tool to setup the Ethernet by RS-232, USB and Ethernet interfaces. The following contents will instruct users how to configure the Ethernet by these three interfaces.

2.3.2 Using USB interface to setup Ethernet interface

1. Connect the print engine and computer with USB cable.
2. Turn on the print engine power switch.
3. Start the Diagnostic Utility by double clicking on the  icon.
4. The Diagnostic Utility default interface setting is USB interface. If USB interface is connected with print engine, no other settings need to be changed in the interface field.

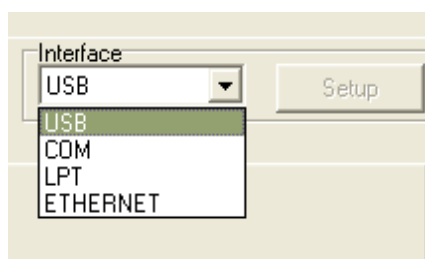

5. Click on the “Ethernet Setup” button from “Printer Function” group in Printer Configuration tab to setup the IP address, subnet mask and gateway for the on board Ethernet.

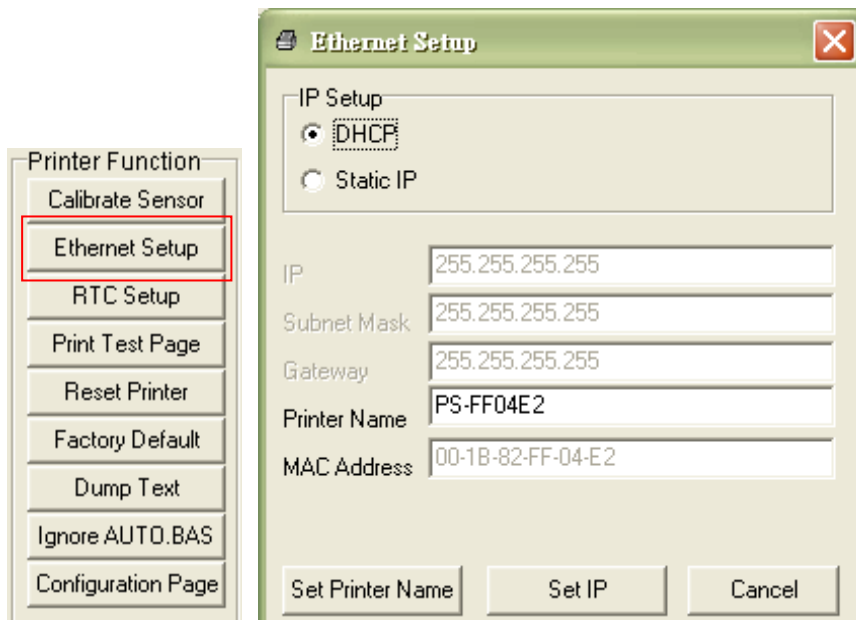

6.3.2 Using RS-232 interface to setup Ethernet interface

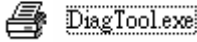
1. Connect the computer and the print engine with a RS-232 cable.
2. Turn on the print engine power.
3. Start the Diagnostic Utility by double clicks on the  icon.
4. Select “COM” as interface then click on the “Setup” button to setup the serial port baud rate, parity check, data bits, stop bit and flow control parameters.

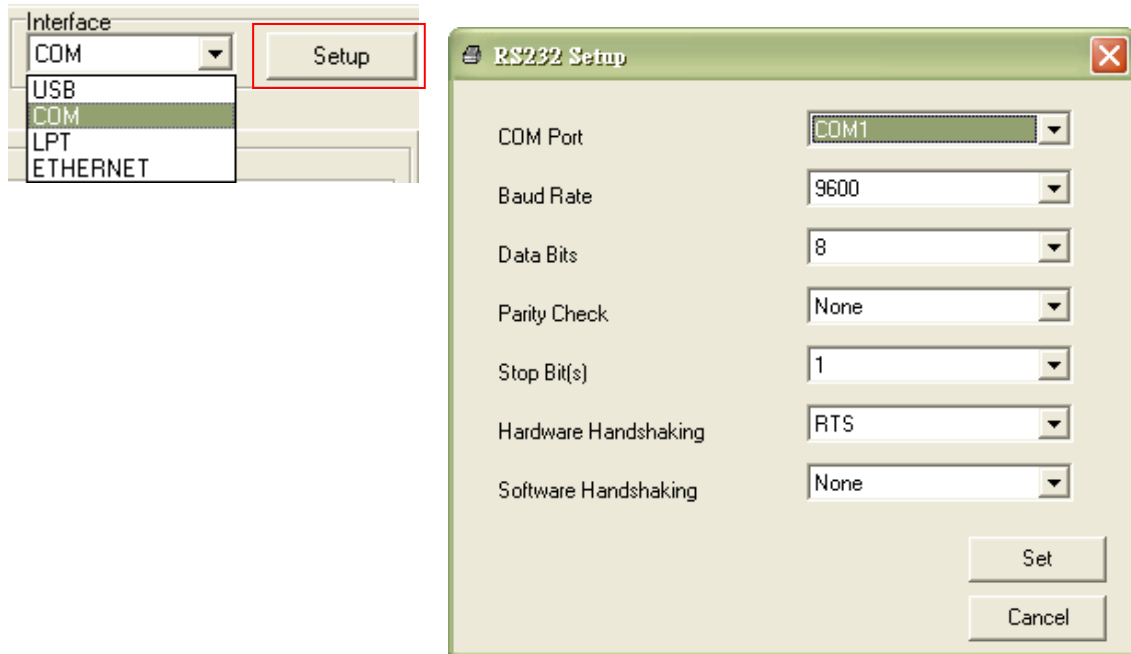

2. Click on the “Ethernet Setup” button from printer function of Printer Configuration tab to setup the IP address, subnet mask and the gateway for the on board Ethernet.

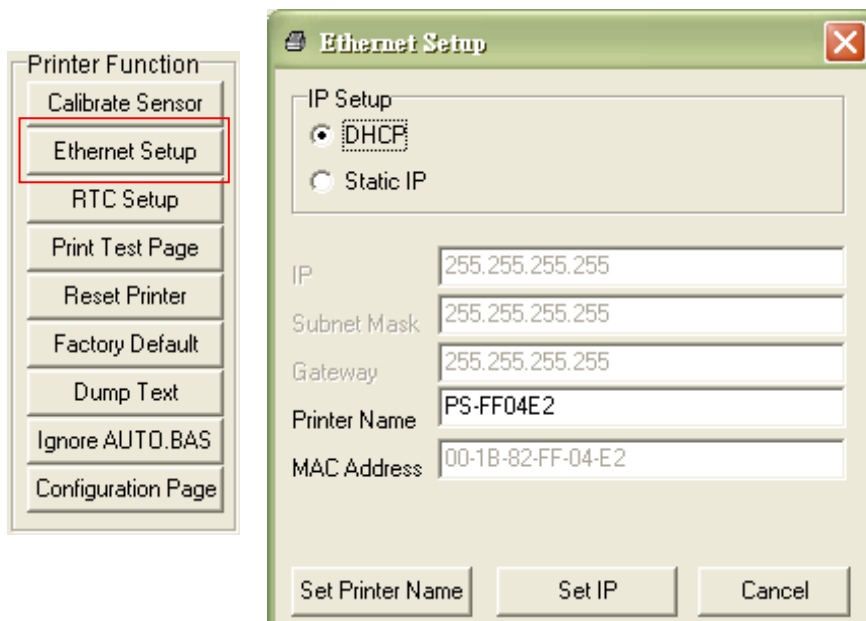

6.3.3 Using Ethernet interface to setup Ethernet interface

1. Connect the computer and the print engine to the LAN.
2. Turn on the print engine power.
3. Start the Diagnostic Utility by double clicks on the  `DiagTool.exe` icon.
4. Select “Ethernet” as the interface then click on the “Setup” button to setup the IP address, subnet mask and gateway for the on board Ethernet.

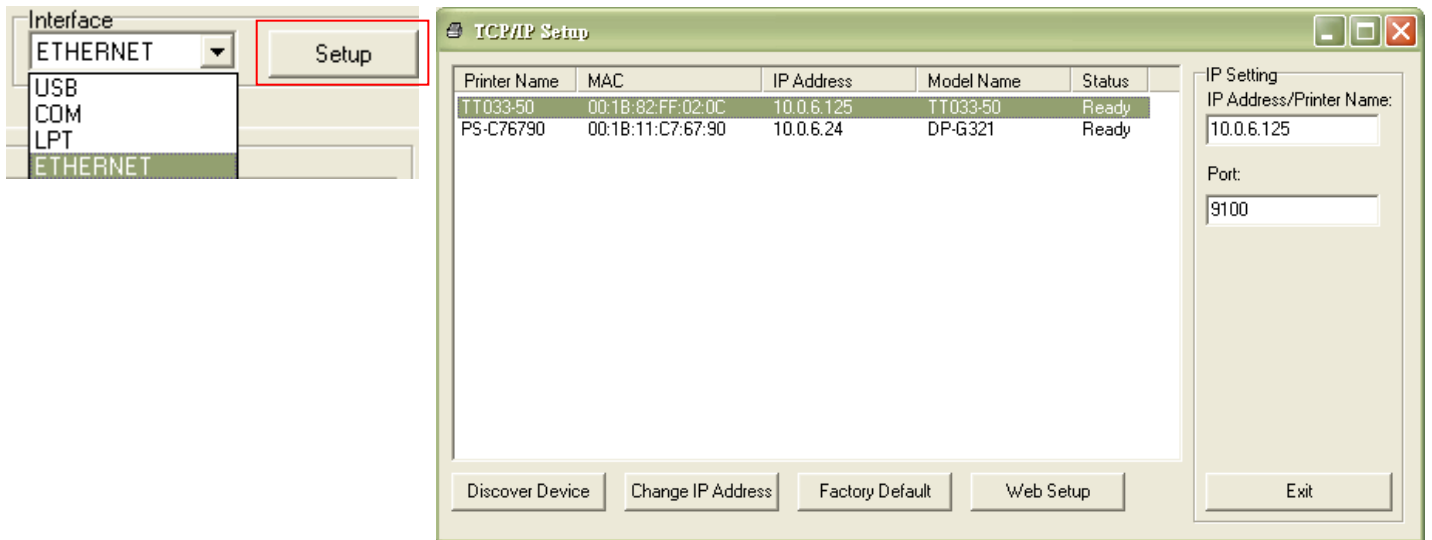

5. Click the “Discover Device” button to explore the printers that exist on the network.
6. Select the printer in the left side of listed printers, the correspondent IP address will be shown in the right side “IP address/Printer Name” field.
7. Click “Change IP Address” to configure the IP address obtained by DHCP or static.

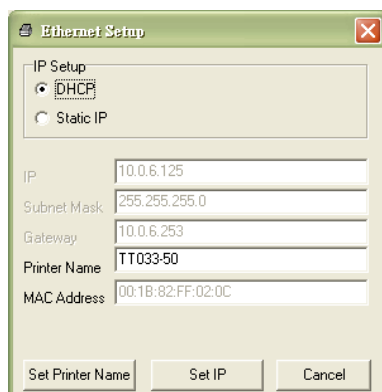

The default IP address is obtained by DHCP. To change the setting to static IP address, click “Static IP” radio button then enter the IP address, subnet mask and gateway. Click “Set IP” to take effect the settings.

Users can also change the “Printer Name” by another model name in this fields then click “Set Printer Name” to take effect this change.

Note: After clicking the “Set Printer Name” or “Set IP” button, print engine will reset to take effect the settings.

2. Click “Exit” button to exit the Ethernet interface setup and go back to Diagnostic Tool main screen.

Factory Default button

This function will reset the IP, subnet mask, gateway parameters obtained by DHCP and reset the printer name.

Web setup button

Except to use the Diagnostic Utility to setup the print engine, you can also explore and configure the print engine settings and status or update the firmware with the IE or Firefox web browser. This feature provides a user friendly setup interface and the capability to manage the print engine remotely over a network.



7. LCD Menu Function

7.1 Enter the Menu

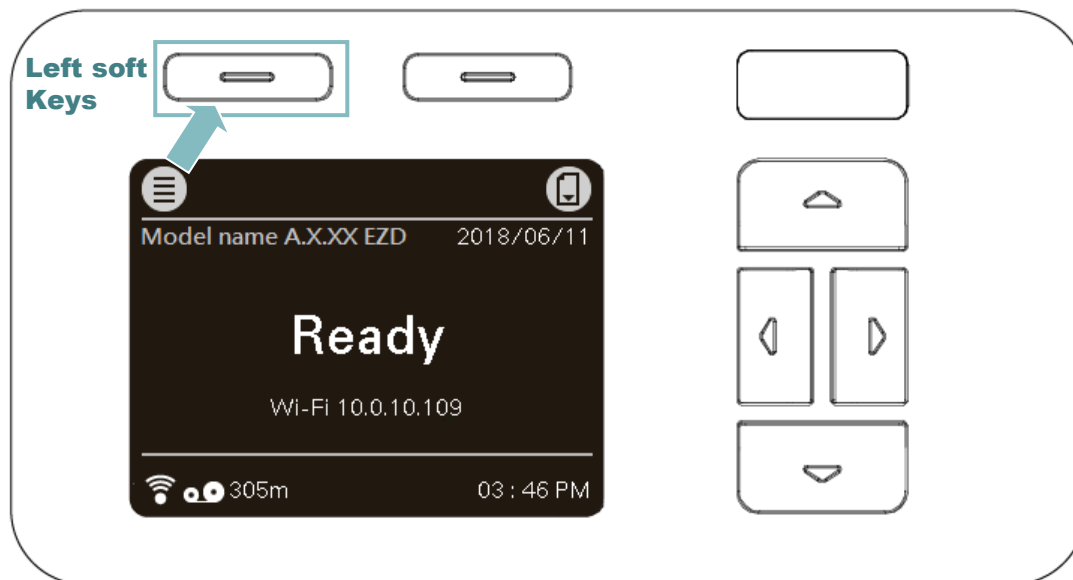
Press the left side soft key (means ) to enter the "Menu".



Use the navigational keys to select the "icon" (be marked in green) and press the right soft key (means

) to enter the selected item. Press left soft key (means ) to back Ready mode.

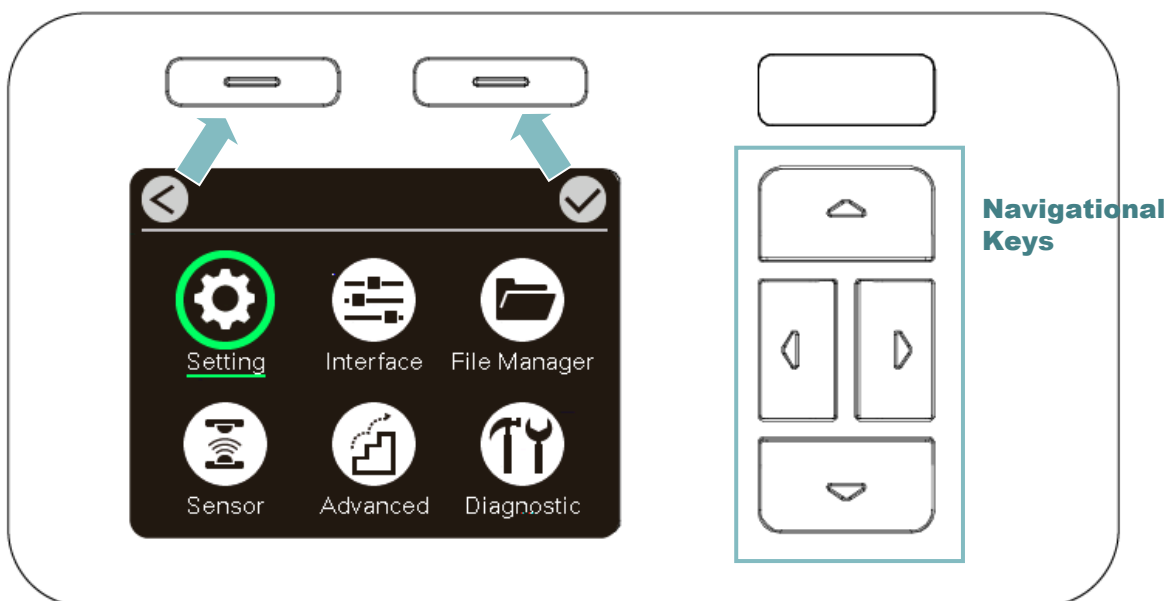

7.2 Menu Overview

There are six categories for the menu. You can easily set the settings of the print engine without connecting the computer. Please refer to the following sections for more details.



This "Setting" category can set up the print engine settings for TSPL & ZPL2.



This "Sensor" option is used to calibrate the selected media sensor. We recommend calibrating the sensor before printing when changing the media.

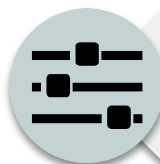

This "Interface" option is used to set the print engine interface settings.

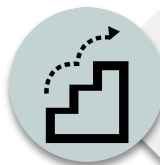

This "Advanced" option is used to set the print engine LCD settings, initialization, ribbon low warning setting %...etc.



This "File Manager" option is used to check/manager the print engine available memory.



This "Diagnostic" option is used to review the print engine to troubleshoot problems and other issues.

7.3 Setting

Press the right soft key to switch the TSPL and the ZPL2. Select the item by navigational key and press right soft key to enter the selected item.

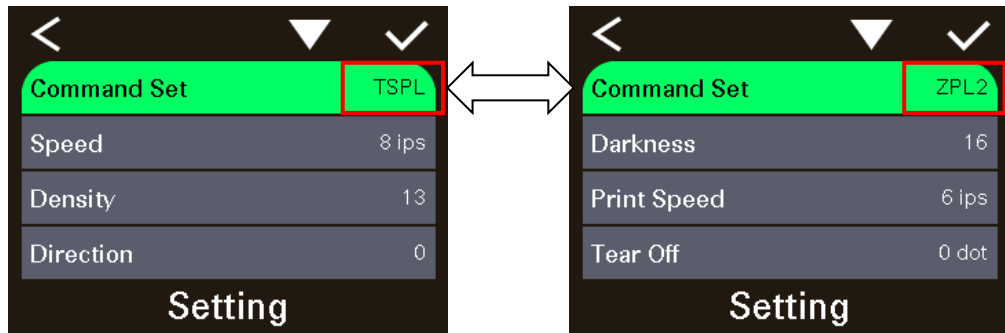

2.3.2 TSPL

This "TSPL" category can set up the print engine settings for TSPL.

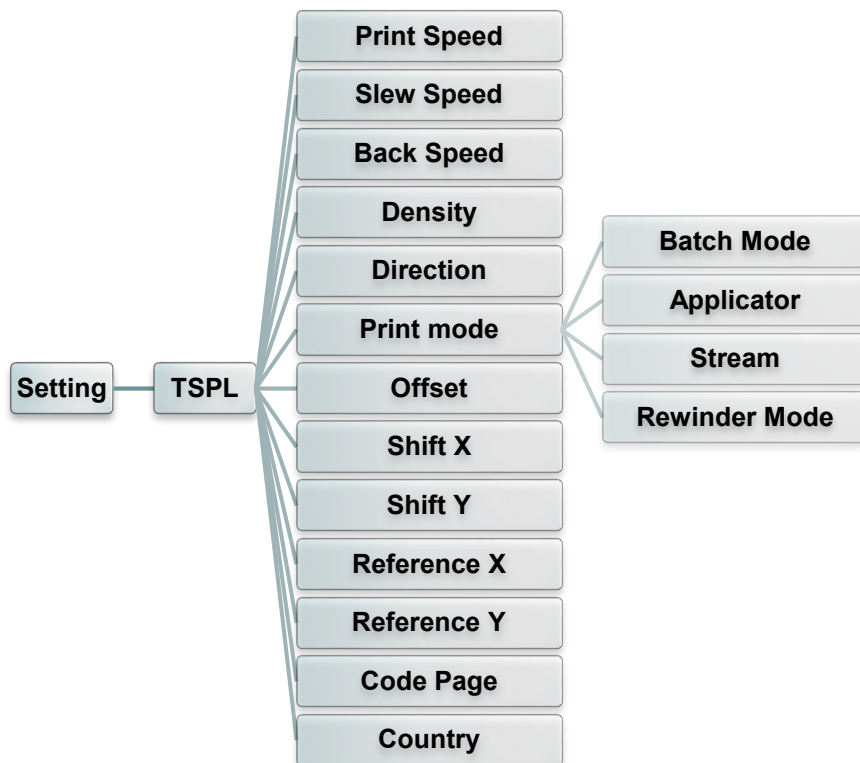

Item	Description	Default
Print Speed	Use this item to setup print speed. Available setting range is 2~18 for 203dpi, 2~14 for 300dpi and 1.5 ~6 for 600dpi.	203 dpi: 6 ips 300 dpi: 4 ips 600 dpi: 3 ips
Slew Speed	Use this item to setup feed speed. Setting value is up to 8 ips.	203 dpi: 6 ips 300 dpi: 4 ips 600 dpi: 3 ips
Back Speed	Use this item to setup back feed speed. Setting value is up to 6 ips.	2 ips

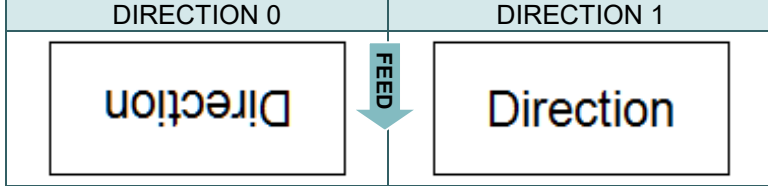
Density	Use this option to setup printing darkness. The available setting range is from 0 to 15, and the step is 1. You may need to adjust your density based on selected media.	8										
Direction	<p>The direction setting value is either 1 or 0. Use this item to setup the printout direction.</p> 	0										
Print mode	<p>This item is used to set the print mode. There are 6 modes as below,</p> <table border="1" data-bbox="411 719 1209 1178"> <thead> <tr> <th>Print Mode</th> <th>Description</th> </tr> </thead> <tbody> <tr> <td>Batch Mode</td> <td>Once image is printed completely, label gap/black mark will be fed to the tear plate location for tear away.</td> </tr> <tr> <td>Applicator</td> <td>The print engine prints a label when it receives a signal from the applicator.</td> </tr> <tr> <td>Stream</td> <td>The print engine prints a batch of labels with backfeed occurring only at the start and end of the batch instead of between individual labels.</td> </tr> <tr> <td>Rewinder Mode</td> <td>The print engine prints without pausing between labels. The media is wound onto a core after printing.</td> </tr> </tbody> </table>	Print Mode	Description	Batch Mode	Once image is printed completely, label gap/black mark will be fed to the tear plate location for tear away.	Applicator	The print engine prints a label when it receives a signal from the applicator.	Stream	The print engine prints a batch of labels with backfeed occurring only at the start and end of the batch instead of between individual labels.	Rewinder Mode	The print engine prints without pausing between labels. The media is wound onto a core after printing.	Batch Mode
Print Mode	Description											
Batch Mode	Once image is printed completely, label gap/black mark will be fed to the tear plate location for tear away.											
Applicator	The print engine prints a label when it receives a signal from the applicator.											
Stream	The print engine prints a batch of labels with backfeed occurring only at the start and end of the batch instead of between individual labels.											
Rewinder Mode	The print engine prints without pausing between labels. The media is wound onto a core after printing.											
Offset	This item is used to fine tune media stop location. Available setting value range is from -999 dots to 999 dots.	0 dot										
Shift X	This item is used to fine tune print position. Available setting value range is from -999 dots to 999 dots.	0 dot										
Shift Y		0 dot										
Reference X	This item is used to set the origin of print engine coordinate system horizontally and vertically. Available setting range is from 0 dot to 999 dots.	0 dot										
Reference Y		0 dot										
Code page	Use this item to set the code page of international character set.	850										
Country	Use this option to set the country code. Available setting value range is from 1 to 358.	001										

Note: If printing from enclosed software/driver, the software/driver will send out the commands, which will overwrite the settings set from the panel.

7.3.2 ZPL2

This “ZPL2” category can set up the print engine settings for ZPL2.

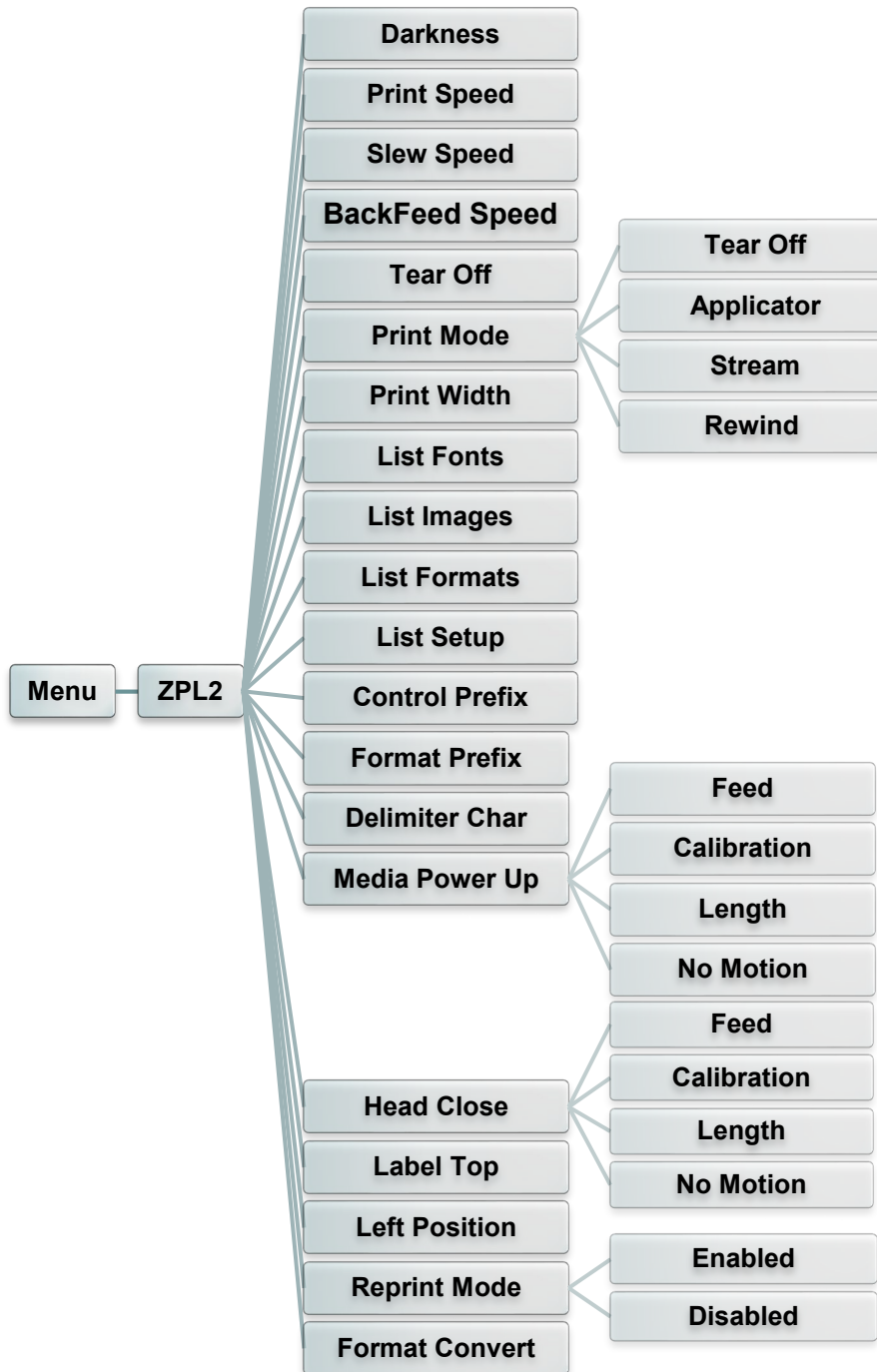

Item	Description	Default
Density	Use this item to setup printing darkness. The available setting range is from 0 to 30. You may need to adjust your density based on selected media.	16
Print Speed	Use this item to setup print speed. Available setting range is 2~18 for 203dpi, 2~14 for 300dpi and 1.5 ~6 for 600dpi.	203 dpi: 6 ips 300 dpi: 4 ips 600 dpi: 3 ips

Slew Speed	Use this item to setup feed speed. Setting value is up to 8 ips.	203 dpi: 6 ips 300 dpi: 4 ips 600 dpi: 3 ips										
BackFeed Speed	Use this item to setup back feed speed. Setting value is up to 6 ips.	2 ips										
Tear Off	This item is used to fine tune media stop location. Available setting value range is from -120~120 dots.	0 dot										
Print mode	<p>This item is used to set the print mode. There are three modes as below,</p> <table border="1"> <thead> <tr> <th>Print Mode</th> <th>Description</th> </tr> </thead> <tbody> <tr> <td>Tear Off</td> <td>The print engine prints label formats as it receives them. The print engine operator can tear off the printed labels any time after they print.</td> </tr> <tr> <td>Applicator</td> <td>The print engine prints a label when it receives a signal from the applicator.</td> </tr> <tr> <td>Stream</td> <td>The print engine prints a batch of labels with backfeed occurring only at the start and end of the batch instead of between individual labels. This setting increases label throughput in batch printing.</td> </tr> <tr> <td>Rewind</td> <td>The print engine prints without pausing between labels. The media is wound onto a core after printing.</td> </tr> </tbody> </table>	Print Mode	Description	Tear Off	The print engine prints label formats as it receives them. The print engine operator can tear off the printed labels any time after they print.	Applicator	The print engine prints a label when it receives a signal from the applicator.	Stream	The print engine prints a batch of labels with backfeed occurring only at the start and end of the batch instead of between individual labels. This setting increases label throughput in batch printing.	Rewind	The print engine prints without pausing between labels. The media is wound onto a core after printing.	Tear Off
Print Mode	Description											
Tear Off	The print engine prints label formats as it receives them. The print engine operator can tear off the printed labels any time after they print.											
Applicator	The print engine prints a label when it receives a signal from the applicator.											
Stream	The print engine prints a batch of labels with backfeed occurring only at the start and end of the batch instead of between individual labels. This setting increases label throughput in batch printing.											
Rewind	The print engine prints without pausing between labels. The media is wound onto a core after printing.											
Print Width	This item is used to set print width. The available value range is 2 ~ 999 dots.	812										
List Fonts	This feature is used to print current print engine available fonts list to the label. The fonts stored in the print engine's DRAM, Flash or optional memory card.	N/A										
List Images	This feature is used to print current print engine available images list to the label. The images stored in the print engine's DRAM, Flash or optional memory card.	N/A										
List Formats	This feature is used to print current print engine available formats list to the label. The formats stored in the print engine's DRAM, Flash or optional memory card.	N/A										
List Setup	This feature is used to print current print engine configuration to the label.	N/A										
Control Prefix	This feature is used to set control prefix character.	N/A										
Format Prefix	This feature is used to set format prefix character.	N/A										
Delimiter Char	This feature is used to set delimiter character.	N/A										
Media Power Up	<p>This option is used to set the action of the media when you turn on the print engine.</p> <table border="1"> <thead> <tr> <th>Selections</th> <th>Description</th> </tr> </thead> <tbody> <tr> <td>Feed</td> <td>Print engine will advance one label</td> </tr> <tr> <td>Calibration</td> <td>Print engine will calibration the sensor levels, determine length and feed label</td> </tr> <tr> <td>Length</td> <td>Print engine determine length and feed label</td> </tr> <tr> <td>No Motion</td> <td>Print engine will not move media</td> </tr> </tbody> </table>	Selections	Description	Feed	Print engine will advance one label	Calibration	Print engine will calibration the sensor levels, determine length and feed label	Length	Print engine determine length and feed label	No Motion	Print engine will not move media	No Motion
Selections	Description											
Feed	Print engine will advance one label											
Calibration	Print engine will calibration the sensor levels, determine length and feed label											
Length	Print engine determine length and feed label											
No Motion	Print engine will not move media											

Head Close	This option is used to set the action of the media when you close the print head.	No Motion										
	<table border="1"> <thead> <tr> <th>Selections</th> <th>Description</th> </tr> </thead> <tbody> <tr> <td>Feed</td> <td>Print engine will advance one label</td> </tr> <tr> <td>Calibration</td> <td>Print engine will calibration the sensor levels, determine length and feed label</td> </tr> <tr> <td>Length</td> <td>Print engine determine length and feed label</td> </tr> <tr> <td>No Motion</td> <td>Print engine will not move media</td> </tr> </tbody> </table>		Selections	Description	Feed	Print engine will advance one label	Calibration	Print engine will calibration the sensor levels, determine length and feed label	Length	Print engine determine length and feed label	No Motion	Print engine will not move media
	Selections		Description									
	Feed		Print engine will advance one label									
	Calibration		Print engine will calibration the sensor levels, determine length and feed label									
Length	Print engine determine length and feed label											
No Motion	Print engine will not move media											
Label Top	This option is used to adjust print position vertically on the label. The range is -120 to +120 dots.	0										
Left Position	This option is used to adjust print position horizontally on the label. The range is -9999 to +9999 dots.	0										
Reprint Mode	When reprint mode is enabled, you can reprint the last label by pressing  button on control panel.	Disabled										
Format Convert	Selects the bitmap scaling factor. The first number is the original dots per inch (dpi) value; the second, the dpi to which you would like to scale.	None										

Note: If printing from enclosed software/driver, the software/driver will send out the commands, which will overwrite the settings set from the panel.

7.4 Sensor

This option is used to calibrate the selected sensor. We recommend calibrate the sensor before printing when changing the media.

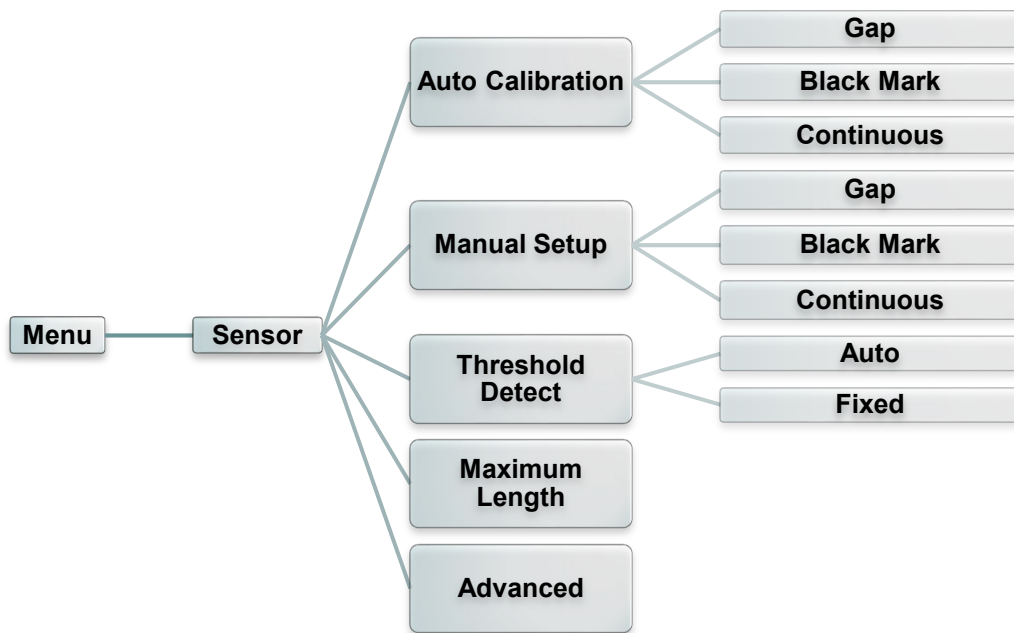

Item	Description	Default
Auto Calibration	This option is used to set the media sensor type and calibrate the selected sensor automatically. Print engine will feed 2 to 3 gap labels to calibrate the sensor sensitivity automatically.	N/A
Manual setup	In case "Automatic" cannot apply to the media, please use "Manual" function to set the paper length and gap/bline size then scan the backing/mark to calibrate the sensor sensitivity.	N/A
Threshold Detect	This option is used to set sensor sensitivity in fixed or auto.	Auto
Maximum Length	This option is used to set the maximum length for label calibration.	254 mm
Advanced	This function can set the minimum paper length and maximum gap/bline length for auto-calibrate the sensor sensitivity.	0 mm

7.5 Interface

This option is used to set the print engine interface settings.

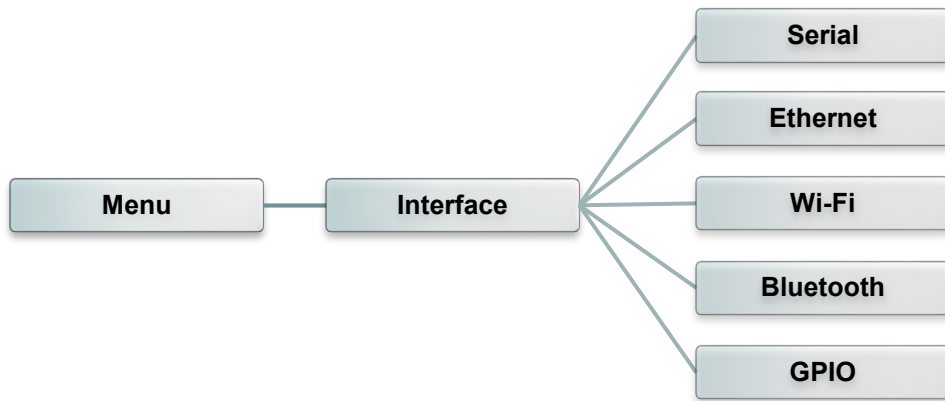

7.5.1 Serial Comm.

This option is used to set the print engine RS-232 settings.

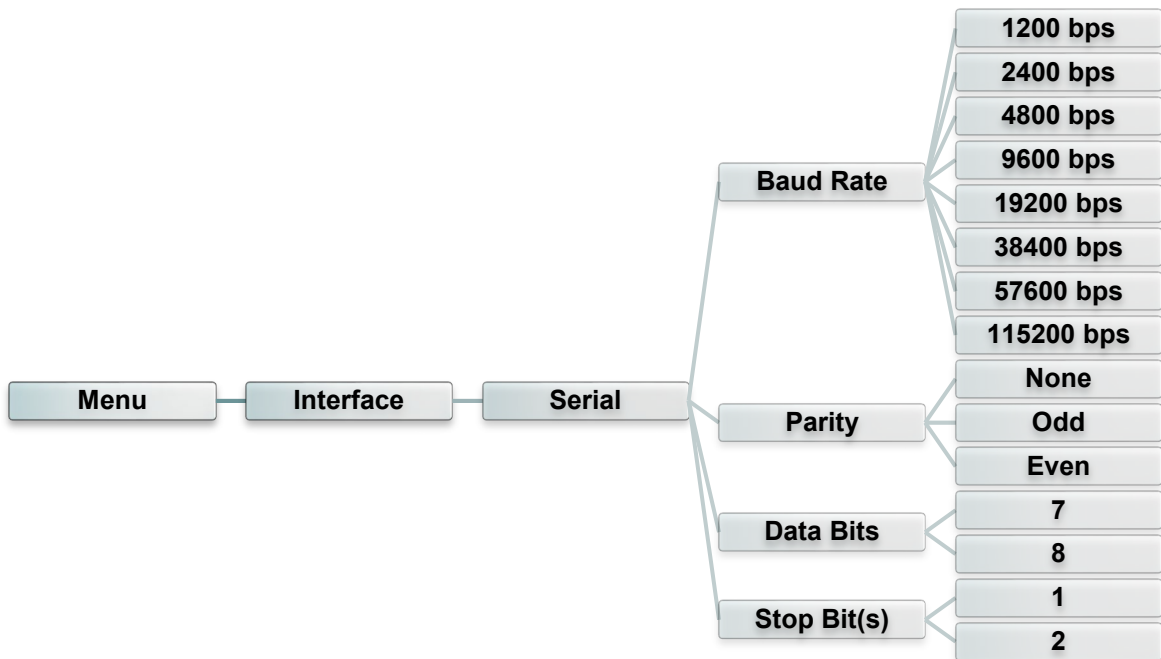

Item	Description	Default
Baud Rate	This item is used to set the RS-232 baud rate.	9600
Parity	This item is used to set the RS-232 parity.	None
Data Bits	This item is used to set the RS-232 Data Bits.	8

Stop Bit(s)	This item is used to set the RS-232 Stop Bits.	1
--------------------	--	----------

7.5.2 Ethernet

Use this menu to configure internal Ethernet configuration check the print engine's Ethernet status, and reset the Ethernet module.

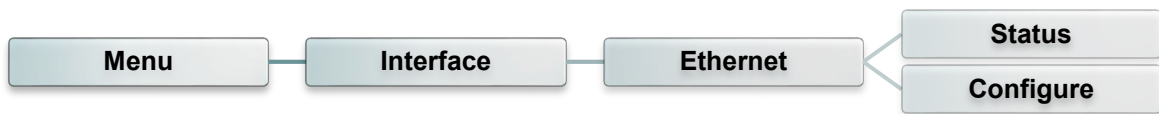

Item	Description	Default
Status	Use this menu to check the IP address and MAC setting status.	N/A
Configure	<p>DHCP: This item is used to ON or OFF the DHCP (Dynamic Host Configuration Protocol) network protocol.</p> <p>Static IP: Use this menu to set the print engine's IP address, subnet mask and gateway.</p>	DHCP

7.5.3 Wi-Fi

This option is used to set the print engine Wi-Fi settings.

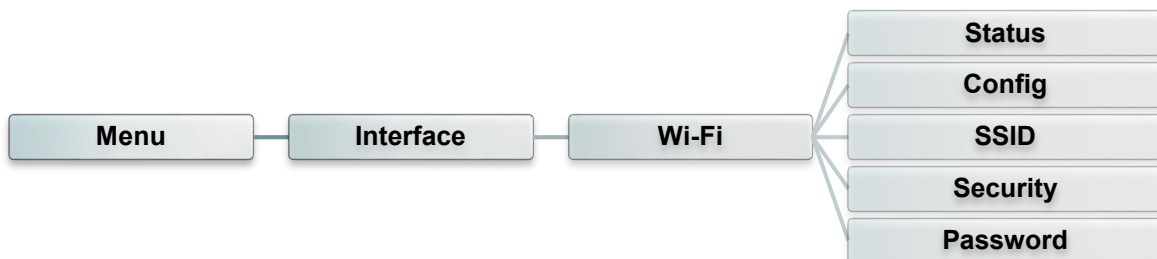

Item	Description	Default
Status	Use this menu to check the Wi-Fi IP address, MAC setting status....	N/A

Configure	<p>DHCP: This item is used to ON or OFF the DHCP (Dynamic Host Configuration Protocol) network protocol.</p> <p>Static IP: Use this menu to set the print engine's IP address, subnet mask and gateway.</p>	DHCP
SSID	Use this menu to set the Wi-Fi SSID	N/A
Security	Use this menu to set the Wi-Fi security	Open
Password	Use this menu to set the Wi-Fi password	N/A

7.5.4 Bluetooth

This option is used to set the print engine Bluetooth settings.

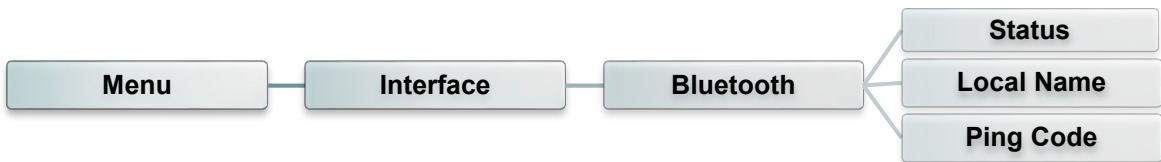

Item	Description	Default
Status	Use this menu to check the Bluetooth status.	N/A
Local Name	This item is used to set the local name for Bluetooth.	RF-BHS
Ping Code	This item is used to set the local ping code for Bluetooth.	0000

7.5.5 GPIO

This option is used to set the print engine GPIO settings. (Applicator interface with DB15F connector +5V I/O)

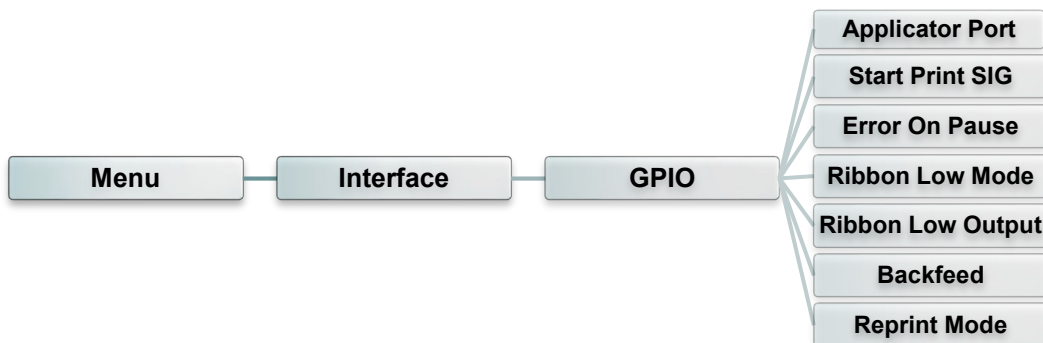

Item	Description	Default																												
Applicator Port	<p>This option is used to set the GPO_3 signal when PRINT END.</p>	Off																												
	<table border="1" style="width: 100%;"> <thead> <tr> <th style="width: 20%;">Selections</th> <th>Description</th> </tr> </thead> <tbody> <tr> <td style="text-align: center;">Off</td> <td>The applicator port is off.</td> </tr> </tbody> </table>		Selections	Description	Off	The applicator port is off.																								
	Selections		Description																											
	Off		The applicator port is off.																											
	<table border="1" style="width: 100%;"> <thead> <tr> <th style="width: 15%;">Mode 1</th> <th style="width: 15%;">Label format sent</th> <th style="width: 15%;">Label format processed</th> <th style="width: 15%;">Waiting for start print signal</th> <th style="width: 15%;">Label prints</th> <th style="width: 15%;">Ready for next label</th> <th style="width: 15%;"></th> </tr> </thead> <tbody> <tr> <td>Data ready (Pin 14, GPO_6)</td> <td></td> <td></td> <td></td> <td></td> <td></td> <td>not ready ready</td> </tr> <tr> <td>Print start (Pin 3, GPI_1)</td> <td></td> <td></td> <td></td> <td></td> <td></td> <td>do not start start</td> </tr> <tr> <td>Print End (Pin 11, GPO_3)</td> <td></td> <td></td> <td></td> <td></td> <td></td> <td>do not end end</td> </tr> </tbody> </table>		Mode 1	Label format sent	Label format processed	Waiting for start print signal	Label prints	Ready for next label		Data ready (Pin 14, GPO_6)						not ready ready	Print start (Pin 3, GPI_1)						do not start start	Print End (Pin 11, GPO_3)						do not end end
	Mode 1		Label format sent	Label format processed	Waiting for start print signal	Label prints	Ready for next label																							
Data ready (Pin 14, GPO_6)						not ready ready																								
Print start (Pin 3, GPI_1)						do not start start																								
Print End (Pin 11, GPO_3)						do not end end																								
<table border="1" style="width: 100%;"> <thead> <tr> <th style="width: 15%;">Mode 2</th> <th style="width: 15%;">Label format sent</th> <th style="width: 15%;">Label format processed</th> <th style="width: 15%;">Waiting for start print signal</th> <th style="width: 15%;">Label prints</th> <th style="width: 15%;">Ready for next label</th> <th style="width: 15%;"></th> </tr> </thead> <tbody> <tr> <td>Data ready (Pin 14, GPO_6)</td> <td></td> <td></td> <td></td> <td></td> <td></td> <td>not ready ready</td> </tr> <tr> <td>Print start (Pin 3, GPI_1)</td> <td></td> <td></td> <td></td> <td></td> <td></td> <td>do not start start</td> </tr> <tr> <td>Print End (Pin 11, GPO_3)</td> <td></td> <td></td> <td></td> <td></td> <td></td> <td>do not end end</td> </tr> </tbody> </table>	Mode 2	Label format sent	Label format processed	Waiting for start print signal	Label prints	Ready for next label		Data ready (Pin 14, GPO_6)						not ready ready	Print start (Pin 3, GPI_1)						do not start start	Print End (Pin 11, GPO_3)						do not end end		
Mode 2	Label format sent	Label format processed	Waiting for start print signal	Label prints	Ready for next label																									
Data ready (Pin 14, GPO_6)						not ready ready																								
Print start (Pin 3, GPI_1)						do not start start																								
Print End (Pin 11, GPO_3)						do not end end																								
<table border="1" style="width: 100%;"> <thead> <tr> <th style="width: 15%;">Mode 3</th> <th style="width: 15%;">Label format sent</th> <th style="width: 15%;">Label format processed</th> <th style="width: 15%;">Waiting for start print signal</th> <th style="width: 15%;">Label prints</th> <th style="width: 15%;">Ready for next label</th> <th style="width: 15%;"></th> </tr> </thead> <tbody> <tr> <td>Data ready (Pin 14, GPO_6)</td> <td></td> <td></td> <td></td> <td></td> <td></td> <td>not ready ready</td> </tr> <tr> <td>Print start (Pin 3, GPI_1)</td> <td></td> <td></td> <td></td> <td></td> <td></td> <td>do not start start</td> </tr> <tr> <td>Print End (Pin 11, GPO_3)</td> <td></td> <td></td> <td></td> <td></td> <td></td> <td>do not end end</td> </tr> </tbody> </table>	Mode 3	Label format sent	Label format processed	Waiting for start print signal	Label prints	Ready for next label		Data ready (Pin 14, GPO_6)						not ready ready	Print start (Pin 3, GPI_1)						do not start start	Print End (Pin 11, GPO_3)						do not end end		
Mode 3	Label format sent	Label format processed	Waiting for start print signal	Label prints	Ready for next label																									
Data ready (Pin 14, GPO_6)						not ready ready																								
Print start (Pin 3, GPI_1)						do not start start																								
Print End (Pin 11, GPO_3)						do not end end																								
<table border="1" style="width: 100%;"> <thead> <tr> <th style="width: 15%;">Mode 4</th> <th style="width: 15%;">Label format sent</th> <th style="width: 15%;">Label format processed</th> <th style="width: 15%;">Waiting for start print signal</th> <th style="width: 15%;">Label prints</th> <th style="width: 15%;">Ready for next label</th> <th style="width: 15%;"></th> </tr> </thead> <tbody> <tr> <td>Data ready (Pin 14, GPO_6)</td> <td></td> <td></td> <td></td> <td></td> <td></td> <td>not ready ready</td> </tr> <tr> <td>Print start (Pin 3, GPI_1)</td> <td></td> <td></td> <td></td> <td></td> <td></td> <td>do not start start</td> </tr> <tr> <td>Print End (Pin 11, GPO_3)</td> <td></td> <td></td> <td></td> <td></td> <td></td> <td>do not end end</td> </tr> </tbody> </table>	Mode 4	Label format sent	Label format processed	Waiting for start print signal	Label prints	Ready for next label		Data ready (Pin 14, GPO_6)						not ready ready	Print start (Pin 3, GPI_1)						do not start start	Print End (Pin 11, GPO_3)						do not end end		
Mode 4	Label format sent	Label format processed	Waiting for start print signal	Label prints	Ready for next label																									
Data ready (Pin 14, GPO_6)						not ready ready																								
Print start (Pin 3, GPI_1)						do not start start																								
Print End (Pin 11, GPO_3)						do not end end																								
<table border="1" style="width: 100%;"> <tbody> <tr> <td style="width: 20%;">Customized</td> <td>Use GPIO setting commands for customized settings. For GPIO command, please refer to TSPL/TSPL2 programming manual.</td> </tr> </tbody> </table>	Customized	Use GPIO setting commands for customized settings. For GPIO command, please refer to TSPL/TSPL2 programming manual.																												
Customized	Use GPIO setting commands for customized settings. For GPIO command, please refer to TSPL/TSPL2 programming manual.																													
Start Print SIG	This determines the trigger conditions for the printer to control GPI 1 and GPI4.	Level mode																												

Error On Pause	When this option is enabled and the printer is paused, the error signal (GPO_2) is LOW.	Enable
Ribbon Low Mode	When this option is enabled and the printer is Low Ribbon (GPO_1), the printer will generate a warning.	Enable
Ribbon Low Output	When the Ribbon Low Mode feature is enabled, this parameter determines if the output signal on Pin 9 (GPO_1) is HIGH or LOW.	Active High
Backfeed	This determines the timing of pullback.	Default
Reprint Mode	When this option is disabled, the printer reprint function (GPI_4) will be invalid.	Disable

7.6 Advanced

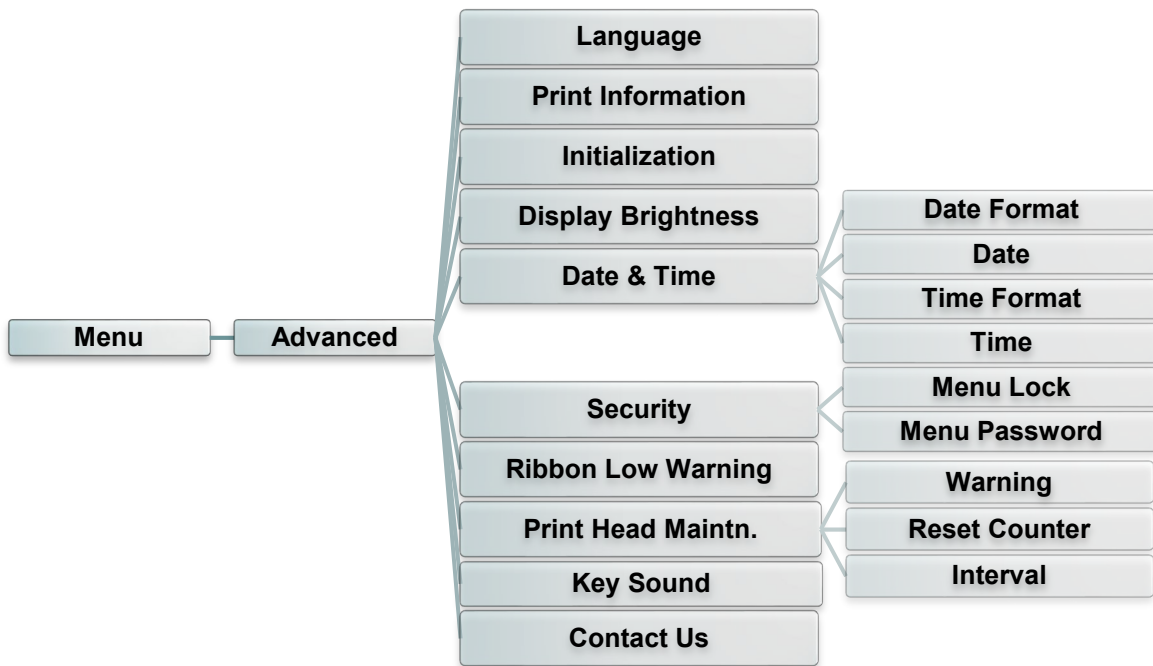

Item	Description	Default
Language	This item is used to setup the language on display.	English
Print Information	This feature is used to check the print engine serial number, printed mileage (m), printed labels (pcs) and cutting counter.	N/A
Initialization	This feature is used to restore print engine settings to defaults.	N/A
Display Brightness	This item is used to setup the brightness for display. (Range 0~100)	50
Date & Time	This item is used to setup the date and time on display.	N/A
Security	This feature is used to set the password for locking the menu. The default password is 8888.	Disable

Ribbon Low Warning	This item is used to set the warning for ribbon low. For example, if setting value is 30m, when ribbon capacity was lower than 30m, the  will be shown in red.	30m								
Print Head Maintn.	<p>This item is used to check print head status and to set the settings for print head care.</p> <table border="1" data-bbox="453 376 1158 931"> <thead> <tr> <th data-bbox="453 376 644 405">Item</th> <th data-bbox="644 376 1158 405">Description</th> </tr> </thead> <tbody> <tr> <td data-bbox="453 405 644 651">Warning</td> <td data-bbox="644 405 1158 651">This item is used to enable/disable the print head clean warning. If enable this feature, once print head has been reached the setting mileage then the warning icon will be shown on print engine UI for reminding user to clean the print head. The default setting is disabled.</td> </tr> <tr> <td data-bbox="453 651 644 775">Reset Counter</td> <td data-bbox="644 651 1158 775">This item is used to reset the print head clean warning mileage after cleaned print head.</td> </tr> <tr> <td data-bbox="453 775 644 931">Interval</td> <td data-bbox="644 775 1158 931">This item is used to set the expected mileage for reminding user to clean the print head. You have to enable the “TPH warning lock” for use. The default setting is 1 km.</td> </tr> </tbody> </table>	Item	Description	Warning	This item is used to enable/disable the print head clean warning. If enable this feature, once print head has been reached the setting mileage then the warning icon will be shown on print engine UI for reminding user to clean the print head. The default setting is disabled.	Reset Counter	This item is used to reset the print head clean warning mileage after cleaned print head.	Interval	This item is used to set the expected mileage for reminding user to clean the print head. You have to enable the “TPH warning lock” for use. The default setting is 1 km.	N/A
Item	Description									
Warning	This item is used to enable/disable the print head clean warning. If enable this feature, once print head has been reached the setting mileage then the warning icon will be shown on print engine UI for reminding user to clean the print head. The default setting is disabled.									
Reset Counter	This item is used to reset the print head clean warning mileage after cleaned print head.									
Interval	This item is used to set the expected mileage for reminding user to clean the print head. You have to enable the “TPH warning lock” for use. The default setting is 1 km.									
Key Sound	This feature is used to turn ON/OFF the key sound.	ON								
Contact us	This feature is used to check the contact information for tech support service	N/A								

7.7 File Manager

This feature is used to check the print engine available memory, show the files list, delete the files or run the files that saved in the print engine DRAM/Flash/Card memory.



7.8 Diagnostic

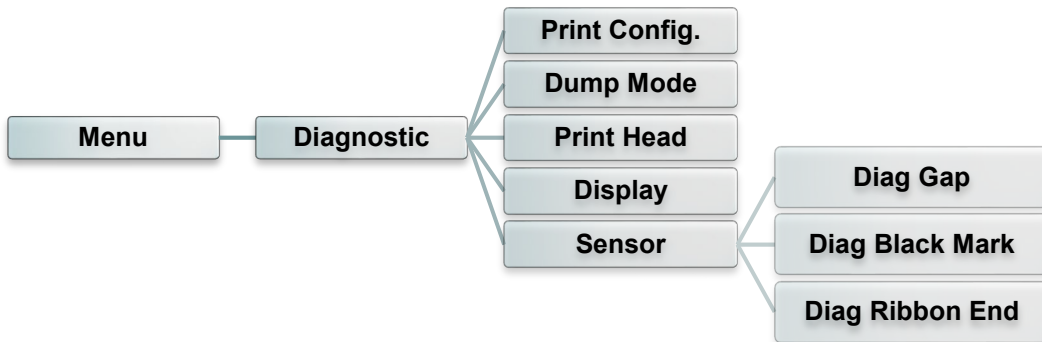

Item	Description																																																														
Print Config.	<p>This feature is used to print current print engine configuration to the label. On the configuration printout, there is a print head test pattern, which is useful for checking if there is any dot damage on the print head heater element.</p> <div style="border: 1px solid black; padding: 5px;"> <p style="text-align: center; margin: 0;">Self-test printout</p> <hr/> <p style="text-align: center; margin: 0;">SYSTEM INFORMATION</p> <hr/> <table style="width: 100%; border-collapse: collapse;"> <tr> <td style="width: 60%;">MODEL: XXXXXX</td> <td style="width: 40%;">Model name</td> </tr> <tr> <td>FIRMWARE: X.XX</td> <td>F/W version</td> </tr> <tr> <td>CHECKSUM: XXXXXXXX</td> <td>Firmware checksum</td> </tr> <tr> <td>S/N: XXXXXXXXXXXX</td> <td>Print engine S/N</td> </tr> <tr> <td>TCF: NO</td> <td>TSC configuration file</td> </tr> <tr> <td>DATE: 1970/01/01</td> <td>System date</td> </tr> <tr> <td>TIME: 00:04:18</td> <td>System time</td> </tr> <tr> <td>NON-RESET: 110 m (TPH)</td> <td rowspan="2">Printed mileage (meter)</td> </tr> <tr> <td>RESET: 110 m (TPH)</td> </tr> <tr> <td>NON-RESET: 0 (CUT)</td> <td rowspan="2">Cutting counter</td> </tr> <tr> <td>RESET: 0 (CUT)</td> </tr> </table> <hr/> <p style="text-align: center; margin: 0;">PRINTING SETTING</p> <hr/> <table style="width: 100%; border-collapse: collapse;"> <tr> <td style="width: 60%;">SPEED: 5 IPS</td> <td style="width: 40%;">Print speed (inch/sec)</td> </tr> <tr> <td>DENSITY: 8.0</td> <td>Print darkness</td> </tr> <tr> <td>WIDTH: 4.00 INCH</td> <td>Label size (inch)</td> </tr> <tr> <td>HEIGHT: 4.00 INCH</td> <td></td> </tr> <tr> <td>GAP: 0.00 INCH</td> <td>Gap distance (inch)</td> </tr> <tr> <td>INTENSION: 5</td> <td>Gap/black mark sensor intension</td> </tr> <tr> <td>CODEPAGE: 850</td> <td>Code page</td> </tr> <tr> <td>COUNTRY: 001</td> <td>Country code</td> </tr> </table> <hr/> <p style="text-align: center; margin: 0;">Z SETTING</p> <hr/> <table style="width: 100%; border-collapse: collapse;"> <tr> <td style="width: 60%;">DARKNESS: 16.0</td> <td style="width: 40%;">ZPL setting information</td> </tr> <tr> <td>SPEED: 4 IPS</td> <td>Print darkness</td> </tr> <tr> <td>WIDTH: 4.00 INCH</td> <td>Print speed (inch/sec)</td> </tr> <tr> <td>TILDE: 7EH (~)</td> <td>Label size</td> </tr> <tr> <td>CARET: 5EH (^)</td> <td>Control prefix</td> </tr> <tr> <td>DELIMITER: 2CH (,)</td> <td>Format prefix</td> </tr> <tr> <td>POWER UP: NO MOTION</td> <td>Delimiter prefix</td> </tr> <tr> <td>HEAD CLOSE: NO MOTION</td> <td>Print engine power up motion</td> </tr> <tr> <td></td> <td>Print head close motion</td> </tr> </table> <hr/> <p style="text-align: center; margin: 0;">RS232 SETTING</p> <hr/> <table style="width: 100%; border-collapse: collapse;"> <tr> <td style="width: 60%;">BAUD: 9600</td> <td style="width: 40%;"></td> </tr> <tr> <td>PARITY: NONE</td> <td></td> </tr> <tr> <td>DATA BIT: 8</td> <td></td> </tr> <tr> <td>STOP BIT: 1</td> <td>RS232 serial port configuration</td> </tr> </table> <hr/> <p style="margin: 0;">Note: ZPL is emulating for Zebra® language.</p> </div>	MODEL: XXXXXX	Model name	FIRMWARE: X.XX	F/W version	CHECKSUM: XXXXXXXX	Firmware checksum	S/N: XXXXXXXXXXXX	Print engine S/N	TCF: NO	TSC configuration file	DATE: 1970/01/01	System date	TIME: 00:04:18	System time	NON-RESET: 110 m (TPH)	Printed mileage (meter)	RESET: 110 m (TPH)	NON-RESET: 0 (CUT)	Cutting counter	RESET: 0 (CUT)	SPEED: 5 IPS	Print speed (inch/sec)	DENSITY: 8.0	Print darkness	WIDTH: 4.00 INCH	Label size (inch)	HEIGHT: 4.00 INCH		GAP: 0.00 INCH	Gap distance (inch)	INTENSION: 5	Gap/black mark sensor intension	CODEPAGE: 850	Code page	COUNTRY: 001	Country code	DARKNESS: 16.0	ZPL setting information	SPEED: 4 IPS	Print darkness	WIDTH: 4.00 INCH	Print speed (inch/sec)	TILDE: 7EH (~)	Label size	CARET: 5EH (^)	Control prefix	DELIMITER: 2CH (,)	Format prefix	POWER UP: NO MOTION	Delimiter prefix	HEAD CLOSE: NO MOTION	Print engine power up motion		Print head close motion	BAUD: 9600		PARITY: NONE		DATA BIT: 8		STOP BIT: 1	RS232 serial port configuration
MODEL: XXXXXX	Model name																																																														
FIRMWARE: X.XX	F/W version																																																														
CHECKSUM: XXXXXXXX	Firmware checksum																																																														
S/N: XXXXXXXXXXXX	Print engine S/N																																																														
TCF: NO	TSC configuration file																																																														
DATE: 1970/01/01	System date																																																														
TIME: 00:04:18	System time																																																														
NON-RESET: 110 m (TPH)	Printed mileage (meter)																																																														
RESET: 110 m (TPH)																																																															
NON-RESET: 0 (CUT)	Cutting counter																																																														
RESET: 0 (CUT)																																																															
SPEED: 5 IPS	Print speed (inch/sec)																																																														
DENSITY: 8.0	Print darkness																																																														
WIDTH: 4.00 INCH	Label size (inch)																																																														
HEIGHT: 4.00 INCH																																																															
GAP: 0.00 INCH	Gap distance (inch)																																																														
INTENSION: 5	Gap/black mark sensor intension																																																														
CODEPAGE: 850	Code page																																																														
COUNTRY: 001	Country code																																																														
DARKNESS: 16.0	ZPL setting information																																																														
SPEED: 4 IPS	Print darkness																																																														
WIDTH: 4.00 INCH	Print speed (inch/sec)																																																														
TILDE: 7EH (~)	Label size																																																														
CARET: 5EH (^)	Control prefix																																																														
DELIMITER: 2CH (,)	Format prefix																																																														
POWER UP: NO MOTION	Delimiter prefix																																																														
HEAD CLOSE: NO MOTION	Print engine power up motion																																																														
	Print head close motion																																																														
BAUD: 9600																																																															
PARITY: NONE																																																															
DATA BIT: 8																																																															
STOP BIT: 1	RS232 serial port configuration																																																														

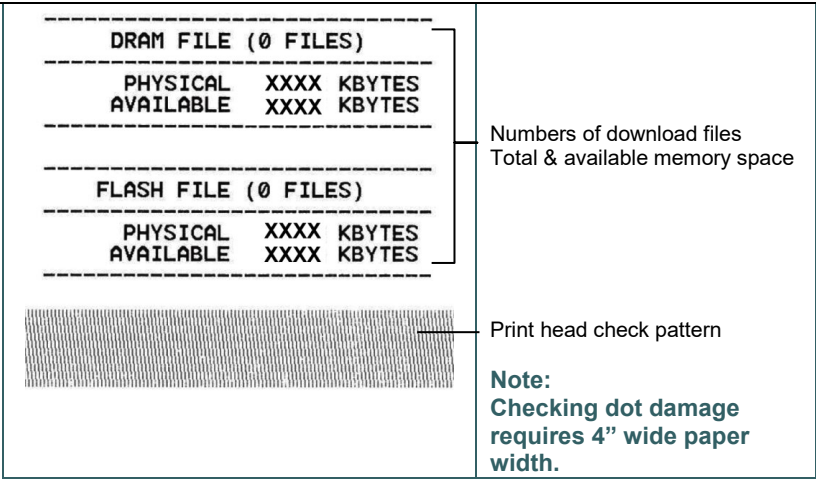
	 <p>Numbers of download files Total & available memory space</p> <p>Print head check pattern</p> <p>Note: Checking dot damage requires 4" wide paper width.</p>
<p>Dump Mode</p>	<p>Captures the data from the communications port and prints out the data received by print engine. In the dump mode, all characters will be printed in 2 columns. The left side characters are received from your system and right side data are the corresponding hexadecimal value of the characters. It allows users or engineers to verify and debug the program.</p> <div style="border: 1px solid black; padding: 10px; margin: 10px auto; width: fit-content;"> <pre> DOWNLO 0D 0A 44 4F 57 4E 4C 4F 4I D "TEST2. 44 20 22 54 45 53 54 32 2E DAT",5,CL 44 41 54 22 2C 35 2C 43 4C S DOWNLO 53 0D 0A 44 4F 57 4E 4C 4F AD F,"TES 41 44 20 46 2C 22 54 45 53 T4.DAT",5 54 34 2E 44 41 54 22 2C 35 ,CLS DOW 2C 43 4C 53 0D 0A 44 4F 57 NLOAD ,"TE 4E 4C 4F 41 44 20 22 54 45 ST2.DAT", 53 54 32 2E 44 41 54 22 2C 5,CLS DO 35 2C 43 4C 53 0D 0A 44 4F WNLOAD F, 57 4E 4C 4F 41 44 20 46 2C "TEST4.DA 22 54 45 53 54 34 2E 44 41 T",5,CLS 54 22 2C 35 2C 43 4C 53 0D DOWNLOAD 0A 44 4F 57 4E 4C 4F 41 44 "TEST2.D 20 22 54 45 53 54 32 2E 44 AT",5,CLS 41 54 22 2C 35 2C 43 4C 53 DOWNLOA 0D 0A 44 4F 57 4E 4C 4F 4I D F,"TEST 44 20 46 2C 22 54 45 53 54 4.DAT",5, 34 2E 44 41 54 22 2C 35 2C CLS 43 4C 53 0D 0A </pre> </div> <p>ASCII Data ←</p> <p>Hexadecimal data related to left column of ASCII data</p> <p>Note: Dump mode requires 4" wide paper width.</p>
<p>Print Head</p>	<p>This feature is used to check print head's temperature and bad dots.</p>
<p>Display</p>	<p>This feature is used to check LCD's color state.</p>
<p>Sensor</p>	<p>This feature is used to check sensors intensity and reading state.</p>

7.9 Favorites

This feature can create customized menu list. You can organize the commonly used setting options to the Favorites list.

- **Enter the “Favorites”**

Press and hold the left side soft key on Ready mode to enter the “Favorites”.

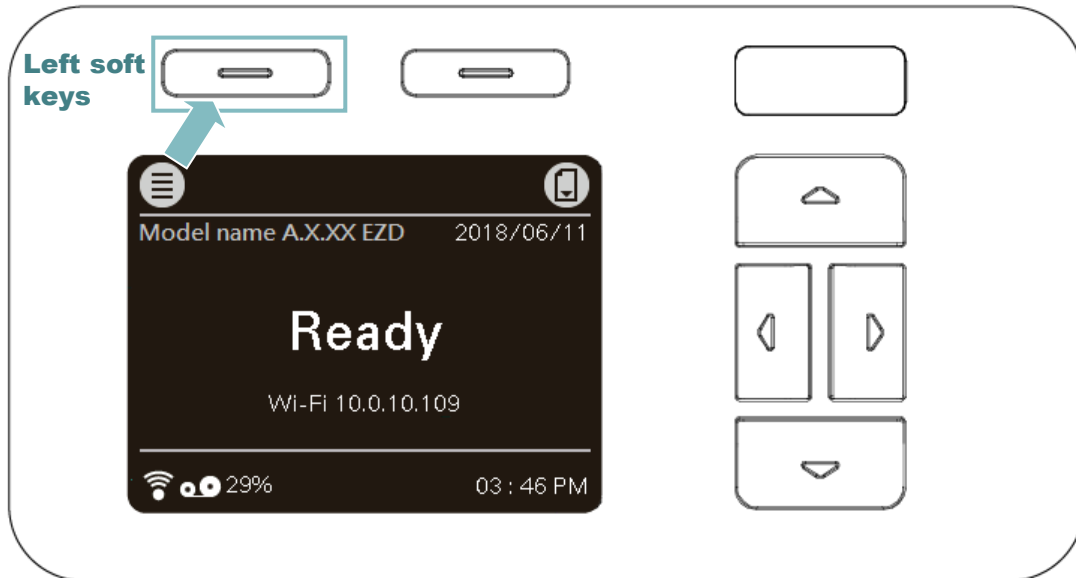

- **Get organized “Favorites” list**

Press and hold right side soft key on the favorite option item, unit “Join Favorites” setting screen pops up. Select “Yes” to add this setting option item to “Favorites” list.

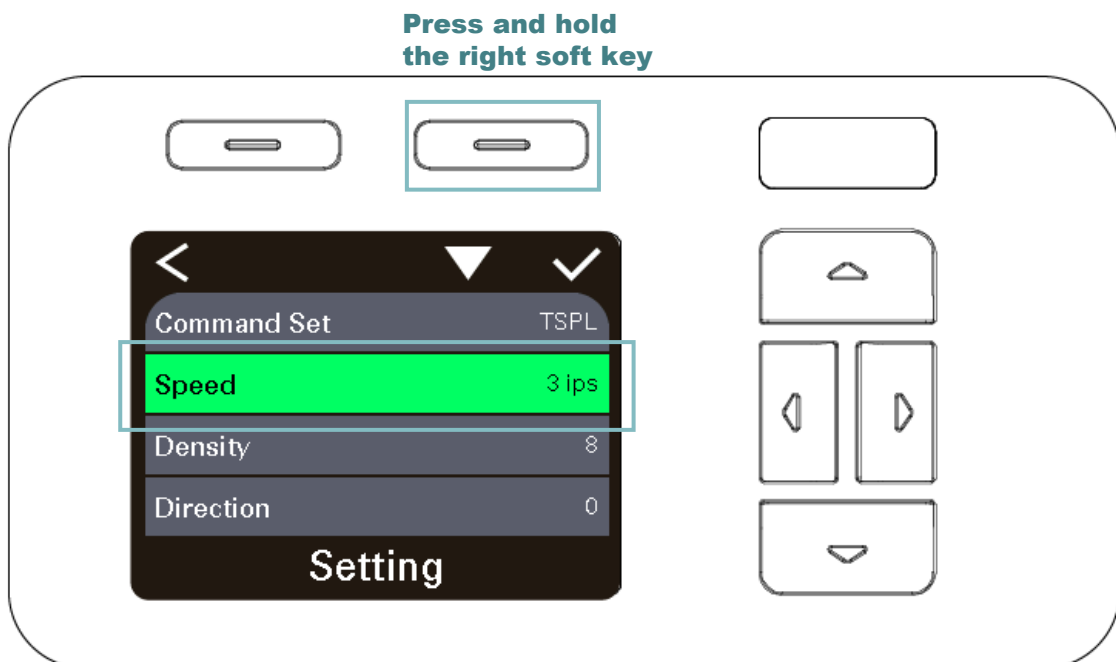

Press right soft keys to join the "Speed" item to the Favorites list

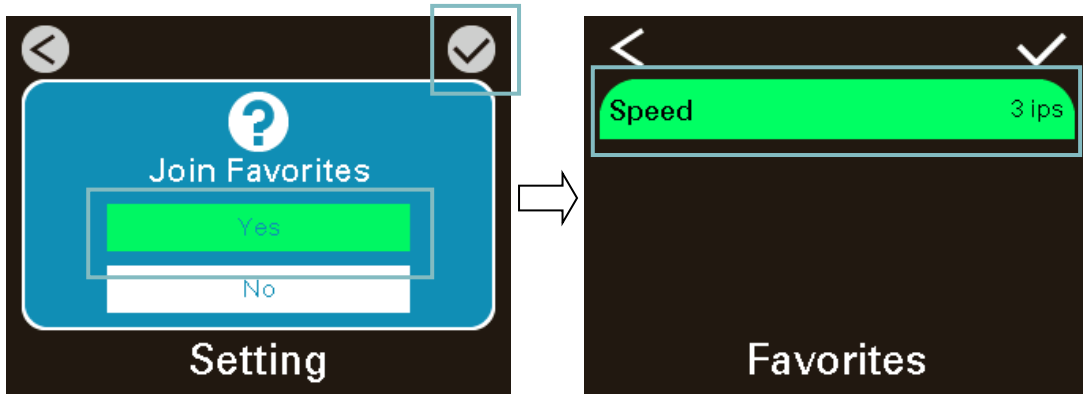

▪ **Delete option item**

Press and hold right side soft key on the item of favorite list, unit "Delete Favorites" setting screen pops up. Select "Yes" to delete this setting option item on "Favorites" list.

Press and hold the right soft key

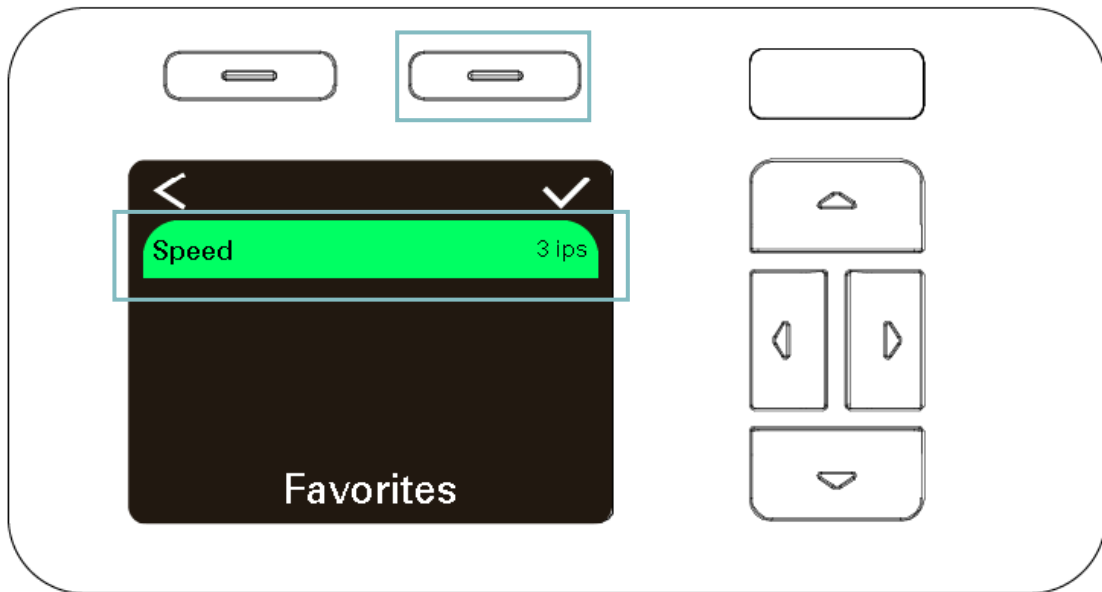

Press right soft keys to delete the "Speed" item on the Favorites list

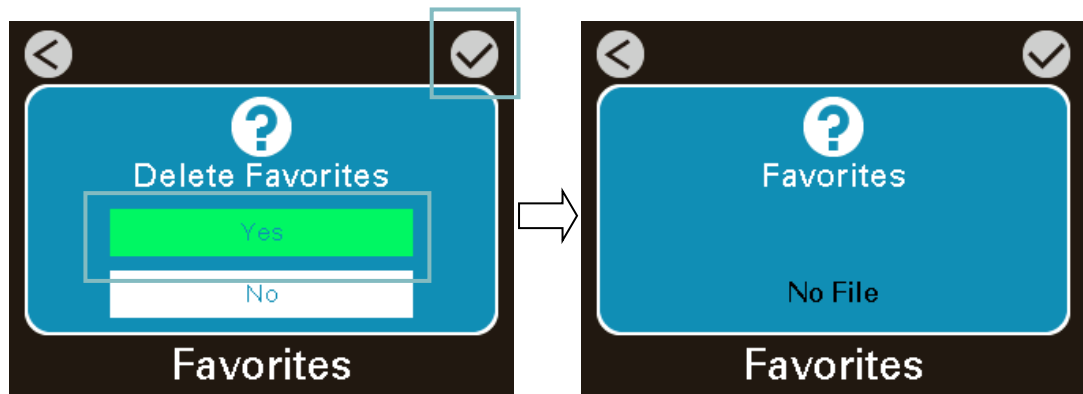

8 Troubleshooting

The following guide lists the most common problems that may be encountered when operating this bar code print engine. If the print engine still does not function after all suggested solutions have been invoked, please contact the Customer Service Department of your purchased reseller or distributor for assistance.

Problem	Possible Cause	Recovery Procedure
Power indicator does not illuminate	* The power cord is not properly connected.	* Plug the power cord in print engine and outlet. * Switch the power on.
Carriage Open	* The print head carriages are open.	* Please close the print carriages.
Not Printing	* Check if interface cable is well connected to the interface connector. * Check if wireless or Bluetooth device is well connected between host and print engine. * The port specified in the Windows driver is not correct.	* Re-connect cable to interface or change a new cable. * Please reset the wireless device setting. * Select the correct print port in the driver. * Clean the printhead. * Printhead's harness connector is not well connected with printhead. Turn off the power and plug the connector again. * Check your program if there is a command PRINT at the end of the file and there must have CRLF at the end of each command line.
No print on the label	* Label or ribbon is loaded not correctly. * Use wrong type paper or ribbon	* Follow the instructions in loading the media and ribbon. * Ribbon and media are not compatible. * Verify the ribbon-inked side. * The print density setting is incorrect.
No Ribbon	* Running out of ribbon. * The ribbon is installed incorrectly.	* Supply a new ribbon roll. * Please refer to the steps in user's manual to reinstall the ribbon.
No Paper	* Running out of label. * The label is installed incorrectly. * Gap/black mark sensor is not calibrated.	* Supply a new label roll. * Please refer to the steps in user's manual to reinstall the label roll. * Calibrate the gap/black mark sensor.
Paper Jam	* Gap/black mark sensor is not set properly. * Make sure label size is set properly. * Labels may be stuck inside the print engine mechanism.	* Calibrate the media sensor. * Set media size correctly. * Remove the stuck label inside the print engine mechanism.
Can't downloading the file to memory (FLASH / CARD)	* The space of memory is full.	* Delete unused files in the memory.
SD card is unable to use	* SD card is damaged. * SD card doesn't insert correctly. * Use the non-approved SD card manufacturer.	* Use the supported capacity SD card. * Insert the SD card again. * The supported SD card spec and the approved SD card manufacturers, please refer to section 2.2.3.

Poor Print Quality	<ul style="list-style-type: none"> * Ribbon and media is loaded incorrectly * Dust or adhesive accumulation on the print head. * Print density is not set properly. * Printhead element is damaged. * Ribbon and media are incompatible. * The printhead pressure is not set properly. 	<ul style="list-style-type: none"> * Reload the supply. * Clean the print head. * Clean the platen roller. * Adjust the print density and print speed. * Run self-test and check the print head test pattern if there is dot missing in the pattern. * Change proper ribbon or proper label media. * Adjust the printhead pressure adjustment knob. * The release lever does not latch the printhead properly.
Missing printing on the left or right side of label	<ul style="list-style-type: none"> * Wrong label size setup. 	<ul style="list-style-type: none"> * Set the correct label size.
Gray line on the blank label	<ul style="list-style-type: none"> * The print head is dirty. * The platen roller is dirty. 	<ul style="list-style-type: none"> * Clean the print head. * Clean the platen roller.
Irregular printing	<ul style="list-style-type: none"> * The print engine is in Hex Dump mode. * The RS-232 setting is incorrect. 	<ul style="list-style-type: none"> * Turn off and on the print engine to skip the dump mode. * Re-set the Rs-232 setting.
Label feeding is not stable (skew) when printing	<ul style="list-style-type: none"> * The media guide does not touch the edge of the media. 	<ul style="list-style-type: none"> * If the label is moving to the right side, please move the label guide to left. * If the label is moving to the left side, please move the label guide to right.
Skip labels when printing	<ul style="list-style-type: none"> * Label size is not specified properly. * Sensor sensitivity is not set properly. * The media sensor is covered with dust. 	<ul style="list-style-type: none"> * Check if label size is setup correctly. * Calibrate the sensor by Auto Gap or Manual Gap options. * Clear the GAP/Black mark sensor by blower.
Wrinkle Problem	<ul style="list-style-type: none"> * Printhead pressure is incorrect. * Ribbon installation is incorrect. * Media installation is incorrect. * Print density is incorrect. * Media feeding is incorrect. 	<ul style="list-style-type: none"> * Please refer to the next chapter. * Please set the suitable density to have good print quality. * Make sure the label guide touch the edge of the media guide.
RTC time is incorrect when reboot the print engine	<ul style="list-style-type: none"> * The battery has run down. 	<ul style="list-style-type: none"> * Check if there is a battery on the main board.
The left side printout position is incorrect	<ul style="list-style-type: none"> * Wrong label size setup. * The parameter Shift X in LCD menu is incorrect. 	<ul style="list-style-type: none"> * Set the correct label size. * Press [MENU] → [SELECT] x 3 → [DOWN] x 5 → [SELECT] to fine tune the parameter of Shift X.

The printing position of small label is incorrect

- * Media sensor sensitivity is not set properly.
- * Label size is incorrect.
- * The parameter Shift Y in the LCD menu is incorrect.
- * The vertical offset setting in the driver is incorrect.

- * Calibrate the sensor sensitivity again.
- * Set the correct label size and gap size.
- * Enter LCD menu (or via DiagTool) to fine tune the parameter of Shift Y.
- * If using the software BarTender, please set the vertical offset in the driver.

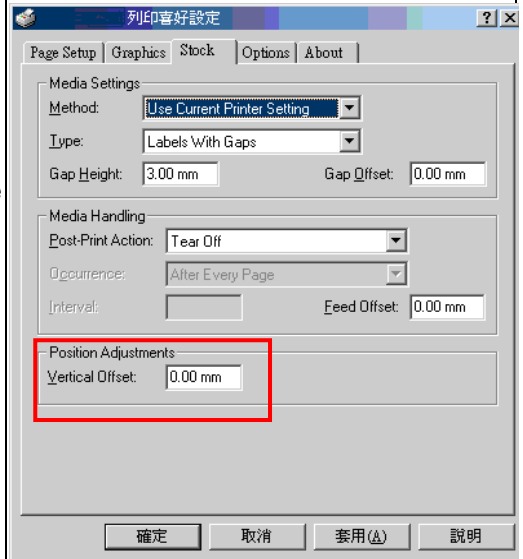

9 Maintenance

This session presents the clean tools and methods to maintain your print engine.

1. Please use one of following material to clean the print engine.
 - Cotton swab
 - Lint-free cloth
 - Vacuum / Blower brush
 - Printhead cleaning pen or 100% Ethanol or Isopropyl Alcohol
2. The cleaning process is described as following,

Print engine Part	Method	Interval
Print Head	1. Always turn off the print engine before cleaning the print head. 2. Allow the print head to cool for a minimum of one minute. 3. Use a cotton swab and 100% Ethanol or Isopropyl Alcohol (or printhead cleaning pen) to clean the print head surface.	Clean the print head when changing a new label roll.
Platen Roller	1. Turn the power off. 2. Rotate the platen roller and wipe it thoroughly with water.	Clean the platen roller when changing a new label roll
Peel Bar	Use the lint-free cloth with 100% ethanol to wipe it.	As needed
Sensor	Compressed air or vacuum	Monthly
Exterior	Wipe it with water-dampened cloth	As needed
Interior	Brush or vacuum	As needed

Note:

- Do not touch printhead by hand. If you touch it careless, please use ethanol to clean it.
- Please use 100% Ethenol or Isopropyl Alcohol. DO NOT use medical alcohol, which may damage the printhead.
- Regularly clean the printhead and supply sensors once change a new media to keep print engine performance and extend print engine life.

Revise History

Date	Content	Editor
2018/8/29	Update the content of Agency Compliance and Approvals	Camille
2018/8/30	Update the BT module SPEC	Camille
2018/9/12	Update the Media Specifications	Camille
2018/11/19	Modify ch. 7.3.1 TSPL	Camille
2018/11/20	Modify ch. 7.3.2 ZPL2	Camille
2018/11/20	Add ch. 7.5.5 GPIO	Camille
2018/12/04	Modify ch.1.2.1, 2.3 and 2.4.3 for GPIO (Applicator interface with DB15F connector +5V I/O)	Camille
2018/12/20	Add reprint feature on GPIO menu (ch. 7.5.5)	Camille
2018/12/20	Modify ch. 2.5, 7.1 & 7.6 for ribbon low warning	Camille
2019/3/15	Modify ch. 7.5.5 for GPIO	Camille
2019/3/29	Modify ch. 7.5.5 for GPIO (Add Backfeed)	Camille
2019/4/29	Modify ch. 2.3	Camille
2019/6/17	Modify ch. 1.6 Label length (for peel mode)	Camille
2019/10/8	Modify CCC certification logo	Kate
2020/4/7	Modify ch. 1.2.2 Optional Features	Camille



TSC Auto ID Technology Co., Ltd.

Corporate Headquarters

9F., No.95, Minquan Rd., Xindian Dist.,
New Taipei City 23141, Taiwan (R.O.C.)

TEL: +886-2-2218-6789

FAX: +886-2-2218-5678

Web site: www.tscprinters.com

E-mail: apac_sales@tscprinters.com

tech_support@tscprinters.com

Li Ze Plant

No.35, Sec. 2, Ligong 1st Rd., Wujie Township,
Yilan County 26841, Taiwan (R.O.C.)

TEL: +886-3-990-6677

FAX: +886-3-990-5577