

**Zebra<sup>®</sup>**  
**GC420t<sup>™</sup>**

---



©2011 ZIH Corp.

P1038982-001

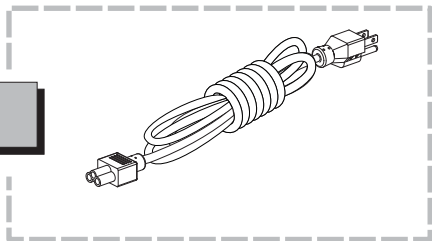
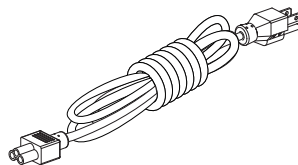
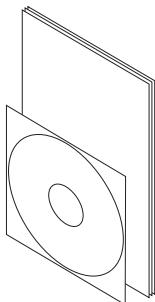
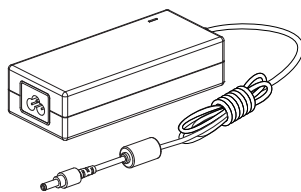
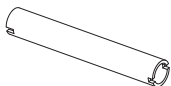
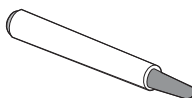
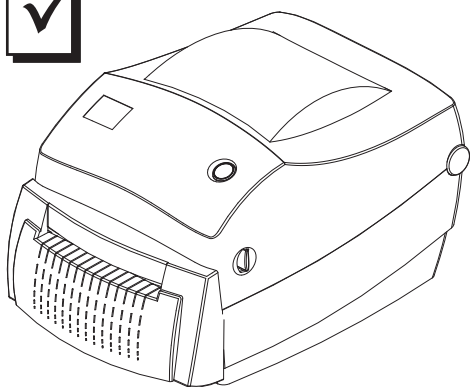
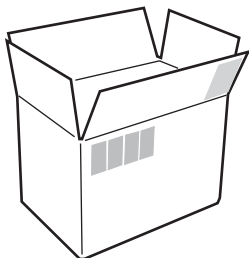

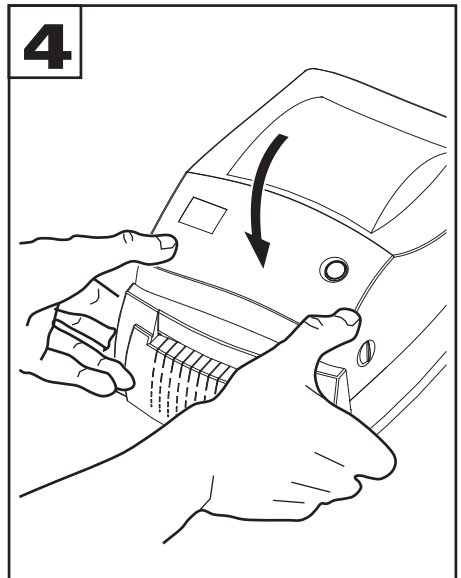
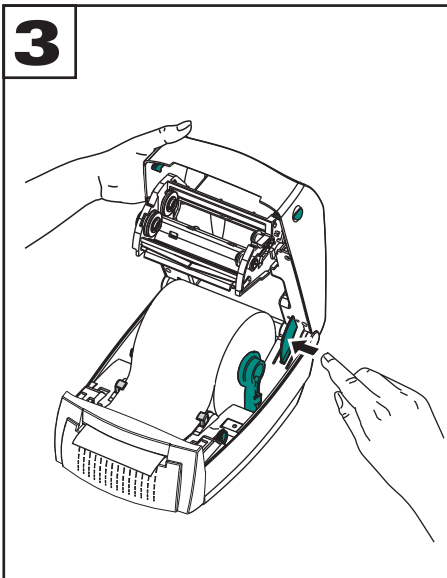
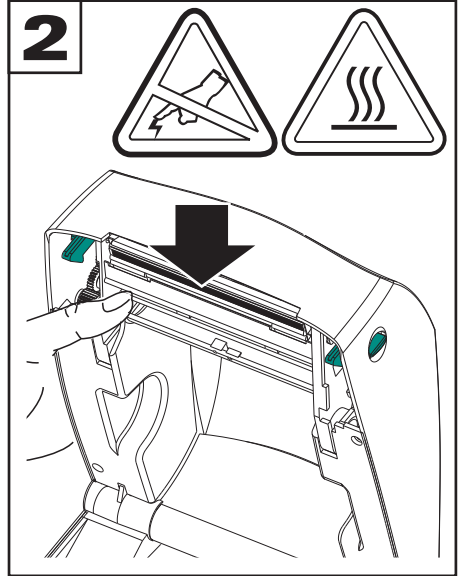
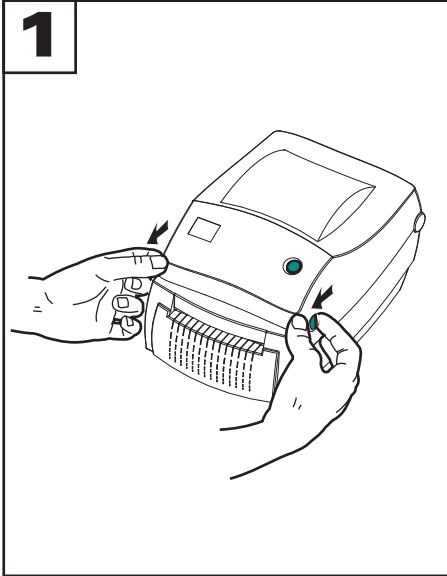

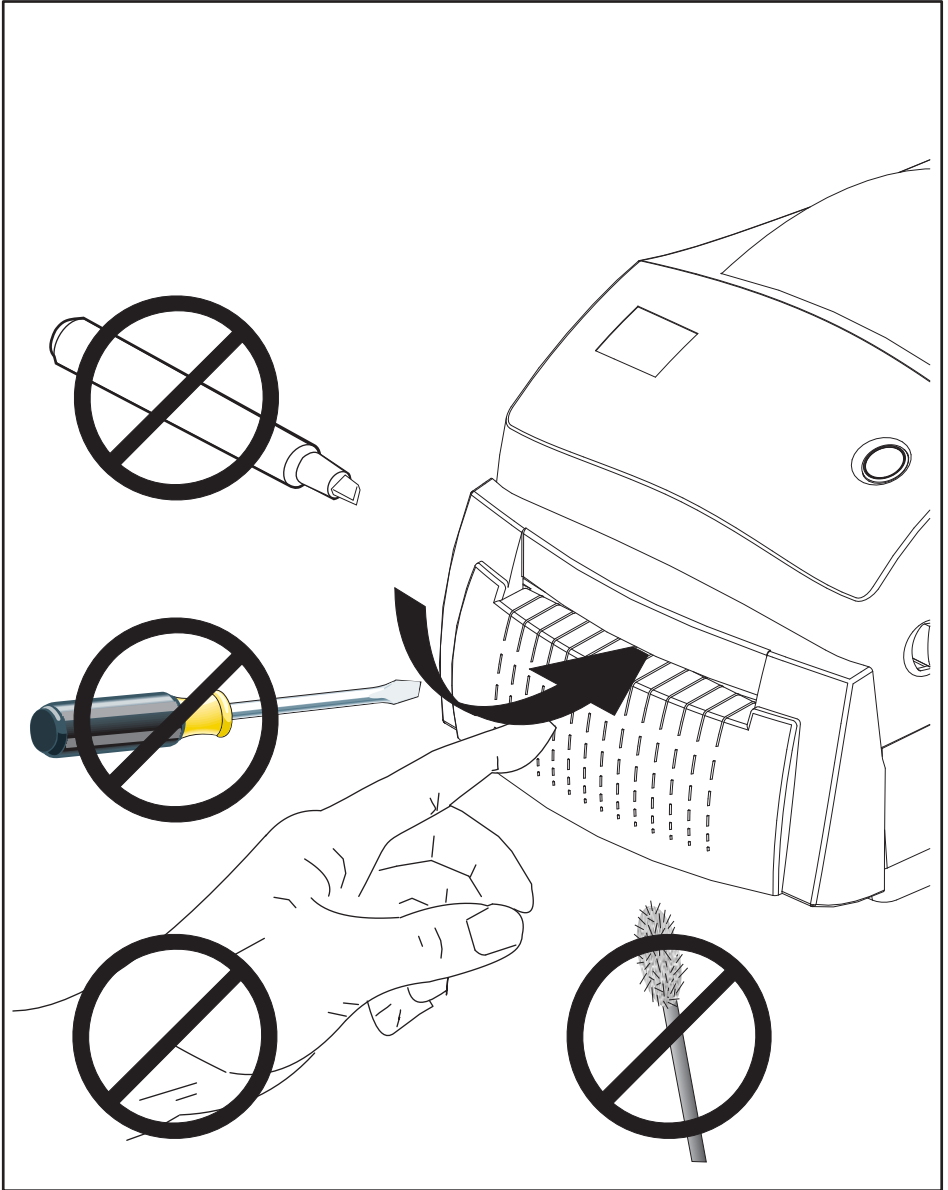





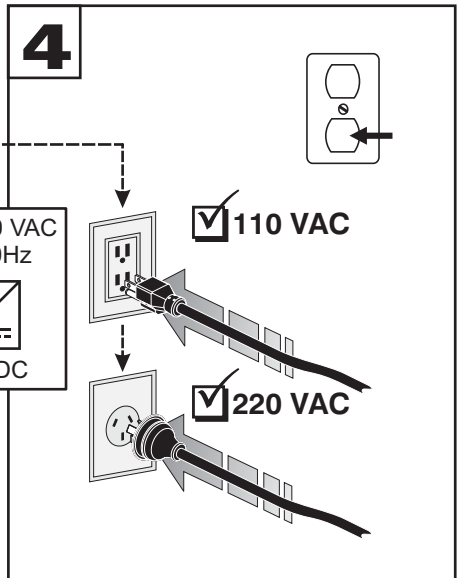
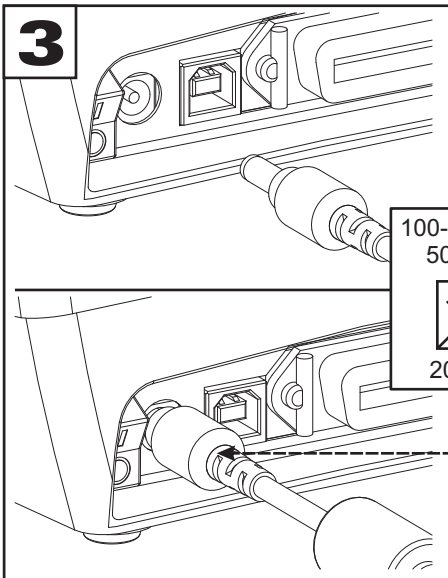
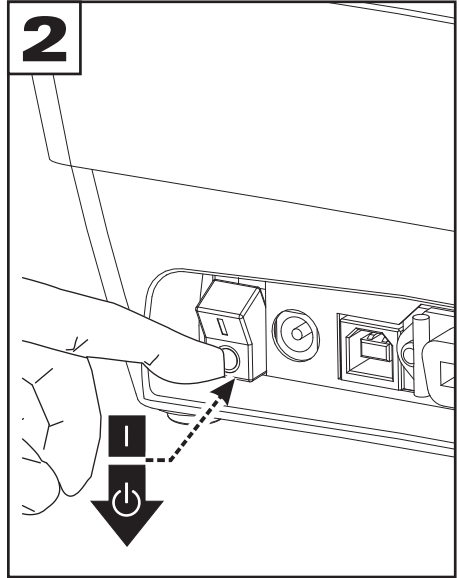
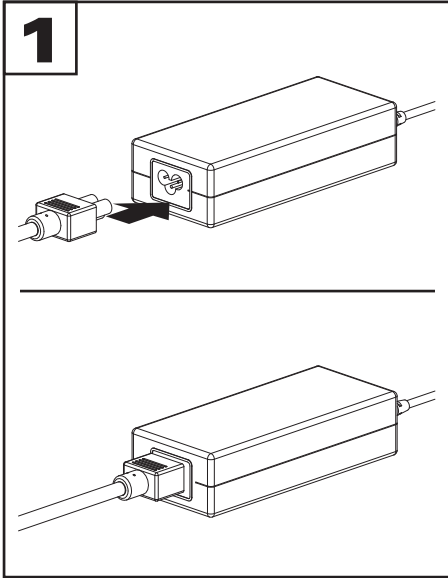

- EN** Ensure that the appropriate power cord with a three (3) prong plug and an IEC 60320-C5 connector is used at all times. This power cord must bear the relevant certification mark of the country in which the product is being used.
- AR** IEC وموصل شوكتات (3) ثلاث ذي بقايس المزود المناسب الطاقة سلك استخدام على احرص الخاصة المناسبة الاعتماد علامة هذا الطاقة سلك يحمل أن يجب . الأوقات جميع في IEC 60320-C5 . فيها المنتج استخدام يتم التي بالدولة .
- BG** Уверете се, че винаги се използва кабел за захранване с щепсел с (3) шипа и IEC 60320-C5 конектор. Този кабел за захранване трябва да има съответния знак за сертификация на страната в която се използва продуктът.
- CS** Vždy se ujistěte, že používáte příslušný napájecí kabel s tří(3)-vodičovou zástrčkou a konektorem IEC 60320-C5. Na tomto napájecím kabelu musí být vyznačena příslušná certifikace země, ve které je produkt používán.
- DA** Sørg for altid at bruge den korrekte netledning med et tre-(3) bensstik og et IEC 60320-C5-stik. Denne netledning skal bære de certificeringsmærker, der gælder i det land, hvor produktet anvendes.
- DE** Das Gerät darf nur über ein dreiadriges Stromkabel (mit Erdung) und ein Kaltgerätestecker gemäß IEC 60320-C5 an das Stromnetz angeschlossen werden. Das verwendete Stromkabel muss zudem das Zertifizierungszeichen einer Prüforganisation des Landes aufweisen, in dem das Gerät betrieben wird.
- EL** Βεβαιωθείτε ότι πάντα χρησιμοποιείται το κατάλληλο ηλεκτρικό καλώδιο με βύσμα τριών (3) ακροδεκτών και σύνδεση IEC 60320-C5. Αυτό το ηλεκτρικό καλώδιο πρέπει να φέρει το σχετικό σήμα πιστοποίησης που ισχύει στη χώρα όπου χρησιμοποιείται το προϊόν.
- ES** Asegúrese de usar siempre el cable de alimentación eléctrica adecuada con un conector de tres (3) patas y un conector IEC 60320-C5. Este cable de alimentación eléctrica deben tener la marca de certificación relevante del país en el cual se utiliza el producto.
- ET** Veenduge, et alati on kasutatud sobivat kolmeharulise (3) pistikuga ja standardile IEC 60320-C5 vastavat toitejuhet. Toitejuhtmel peab olema sobiv serdimärgis selle riigi jaoks, kus toodet kasutatakse.
- FI** Varmista, että asianmukaista virtajohtoa kolmipiikkisellä (3) pistokkeella ja IEC 60320-C5 -liittimellä käytetään aina. Tässä virtajohdossa on oltava tuotteen käyttömaassa asianmukainen sertifiointimerkki.
- FR** Utilisez toujours un cordon d'alimentation approprié comportant une fiche femelle à 2 pôles + terre et un connecteur C.E.I. 60320-C5. Ces cordons d'alimentation doivent porter la marque de certification en vigueur dans le pays où ils sont utilisés.
- HR** Pazite da se uvijek koristi kabel za napajanje s tri (3) ušice na jednom kraju i konektor IEC 60320-C5. Kabel napajanja mora nositi oznaku atesta zemlje u kojoj se proizvod koristi.
- HU** Mindig csak megfelelő, három (3) pontos dugasszal ellátott zsinórt és IEC 60320-C5 típusú csatlakozót használjon. Az ilyen csatlakozó zsinóron rajta kell lenni annak az országnak a tanúsító jelölésének, ahol a terméket használják.
- IT** Assicurarsi di utilizzare sempre un cavo tripolare e un connettore IEC 60320-C5. Sul cavo di alimentazione deve essere riportato il marchio di certificazione del paese in cui viene utilizzato il prodotto.
- JA** 三つ又の差し込みおよび IEC 60320-C5 コネクタの付いた適切な電源コードが常に使用されていることを確認してください。これらの電源コードは製品が使用されている国の関連認証マークが付いている必要があります。

- KO** 항상 3구 플러그 및 IEC 60320-C5 커넥터가 있는 적절한 전원 코드를 사용하고 있는 지 확인하십시오. 이러한 전원 코드는 제품이 사용되는 국가의 관련 인증 표시를 부착해야 합니다.
- LT** Patikrinkite, kad visada naudojamas tinkamas maitinimo laidas su trijų (3) šakučių kištuku ir IEC 60320-C5 jungiklis. Maitinimo laidas turi būti pažymėtas reikiama sertifikavimo šalyje, kurioje yra naudojamas, žyme.
- LV** Pārlicinieties, ka vienmēr tiek izmantots piemērots strāvas vads ar trīs (3) tapām un IEC 60320-C5 standartiem atbilstošu savienotāju. Uz strāvas vada jābūt redzamai tās valsts sertifikācijas zīmei, kurā izstrādājums tiek izmantots.
- NL** Zorg ervoor dat u altijd het juiste netsnoer gebruikt, met een driepolige stekker en een IEC 60320-C5 aansluiting. Het netsnoer moet het juiste keurmerk hebben van het land waarin het product wordt gebruikt.
- NO** Pass på at riktig strømledning med trepolet (3) plugg og IEC 60320-C5-kontakt brukes til enhver tid. Strømledningen må ha riktig sertifiseringsmerke for det landet som produktet brukes i.
- PL** Upewnij się, że do podłączenia zasilania zawsze używany jest przewód zakończony z jednej strony trzystykową (3) wtyczką, a z drugiej - złączem IEC 60320-C5. Ten przewód zasilający musi posiadać oznaczenia certyfikatów wymaganych w kraju użytkowania produktu.
- PT** Assegure-se de que o cabo de alimentação apropriado com um plugue de 3 (três) pinos e um conector IEC 60320-C5 está sendo usado todo o tempo. Esse cabo de alimentação deve ter a marca de certificação correspondente ao país no qual o produto está sendo usado.
- RO** Utilizați mereu cablul de alimentare adecvat cu un ștecher cu trei (3) picioare și cu mufă IEC 60320-C5. Acest cablu de alimentare trebuie să aibă înscris marcajul de certificare corect al țării în care este utilizat echipamentul.
- RU** Убедитесь, что всегда используется кабель питания с трехконтактной штекерной вилкой и разъемом IEC 60320-C5. Кабель питания должен иметь отметку сертификата страны, в которой используется продукт.
- SK** Zastite, aby sa vždy používal príslušný kábel elektrického napájania s trojvidlicovou zásuvkou spĺňajúcou normu IEC 60320-C5. Na tomto kábli musí byť uvedená príslušná značka certifikácie krajiny, v ktorej sa zariadenie používa.
- SL** Zagotovite, da se vedno uporablja ustrezni napajalni kabel z vtičem s tremi (3) nožicami in priključkom IEC 60320-C5. Ta napajalni kabel mora imeti ustrezno oznako certifikata v državi, kjer se uporablja.
- SV** Se till att alltid använda en lämplig nätkabel som har en nätuttagskontakt med tre (3) stift och en IEC 60320-C5-kontakt. Nätkabeln måste ha rätt godkännandemärkning för det land där produkten används.
- TH** ตรวจสอบให้แน่ใจว่าใช้สายไฟที่มีปลั๊กแบบสาม (3) ขาและขั้วต่อ IEC 60320-C5 ที่เหมาะสมเสมอ  
สายไฟนี้จะต้องมีเครื่องหมายการรับรองที่เกี่ยวข้องตามประเทศที่ใช้งานผลิตภัณฑ์ฯ
- TR** Her zaman üç (3) tırnaklı fişi olan uygun bir güç kablosu ve IEC 60320-C5 konektör kullandığınızdan emin olun. Bu güç kablosunun ürünün kullanılmakta olduğu ülkenin ilgili onay damgasını taşımalıdır.
- ZHCN** 应确保使用具有三项 (3) 插头和 IEC 60320-C5 接头的合格电源线。此电源线必须带有产品所在国的相关认证标志。
- ZHTW** 請務必確認使用正確的三腳插頭電源線和 IEC 60320-C5 接頭。這些電源線必須標示使用產品當地的相關認證標誌。

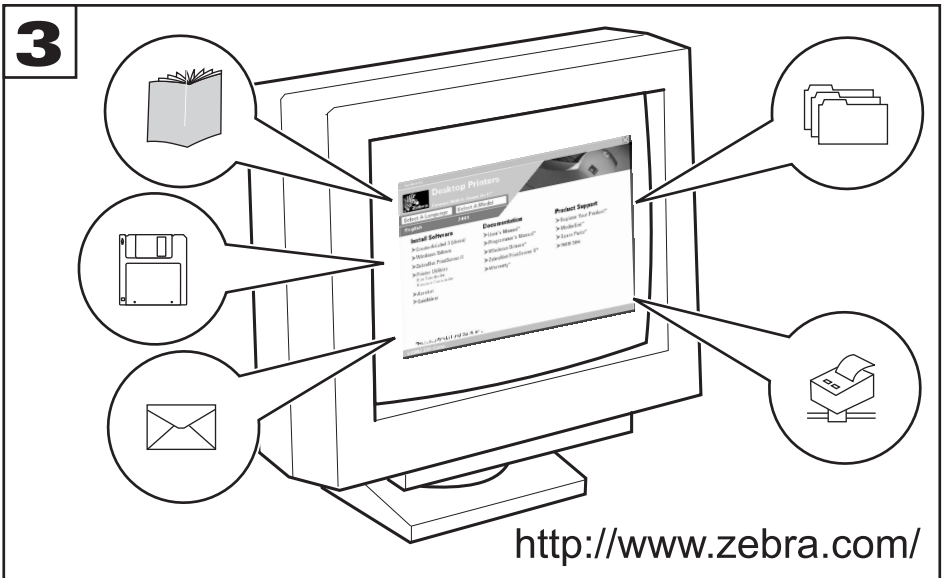
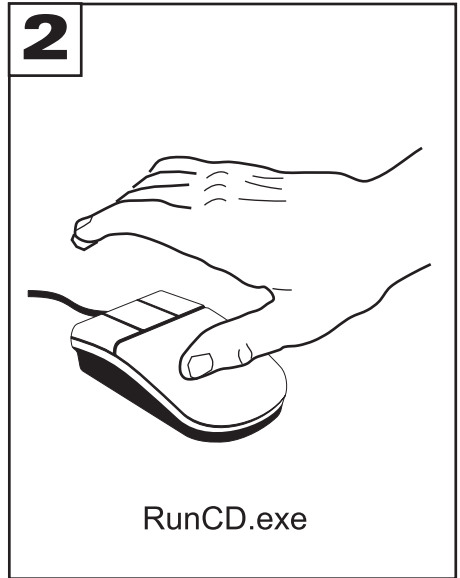
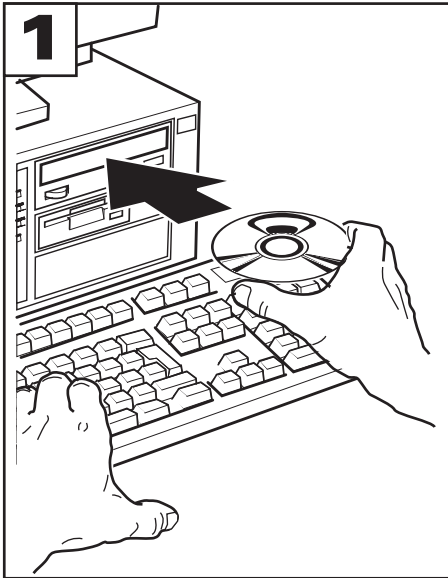
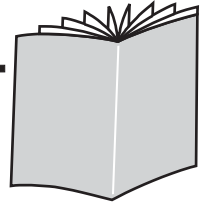

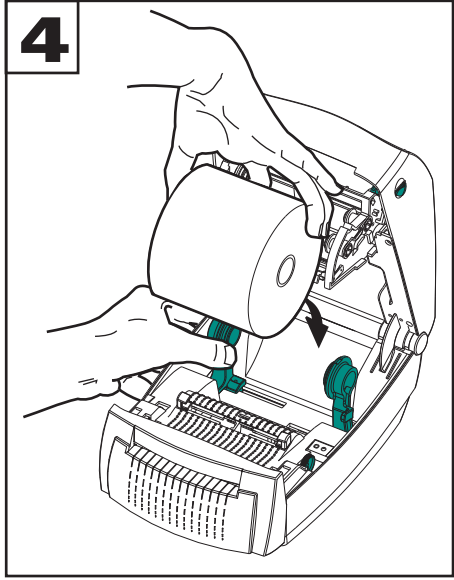
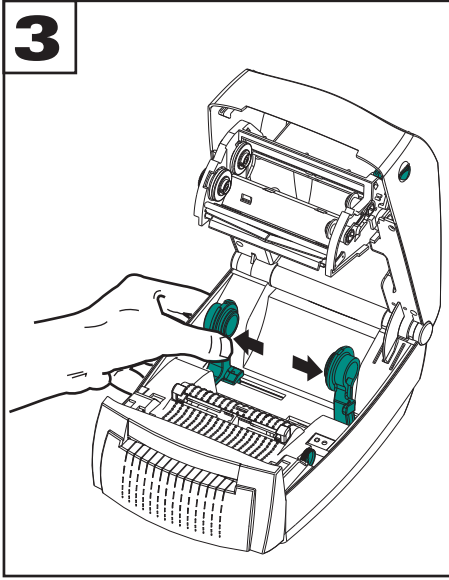
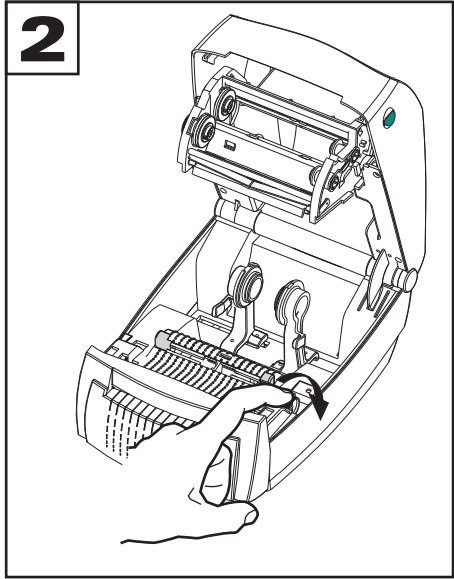
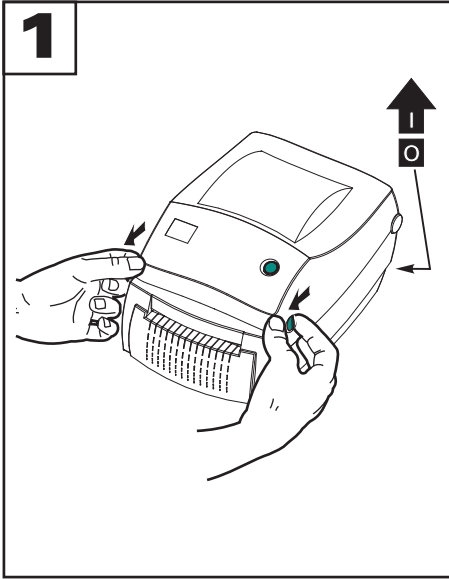
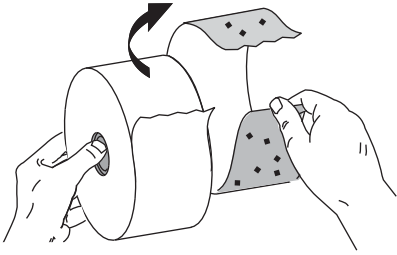

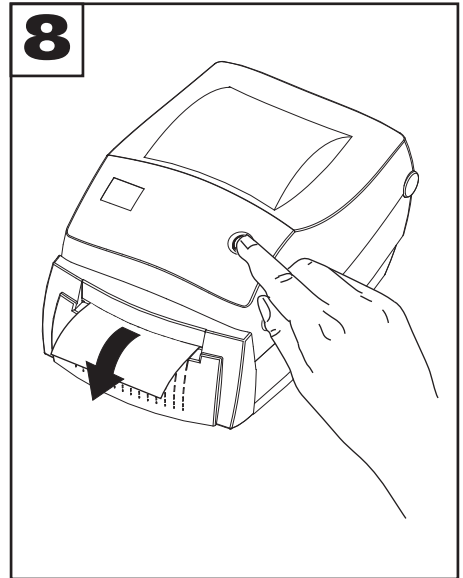
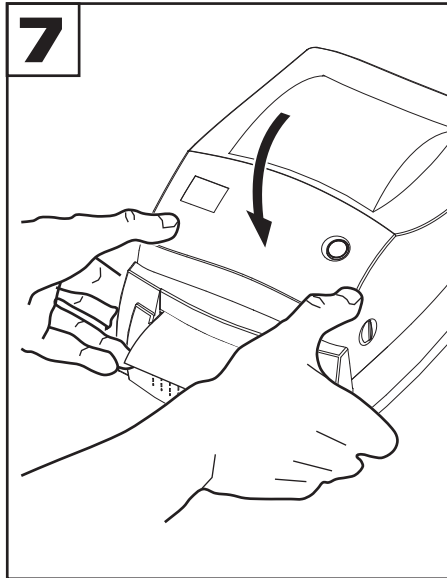
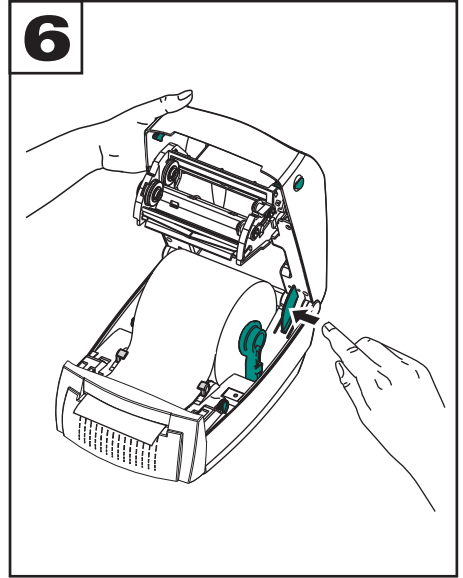
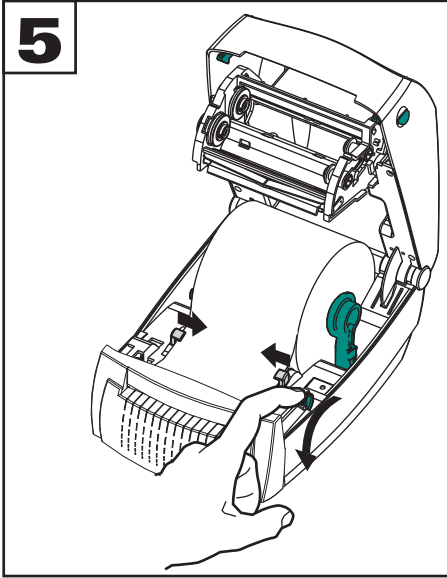
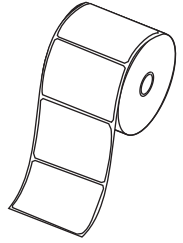

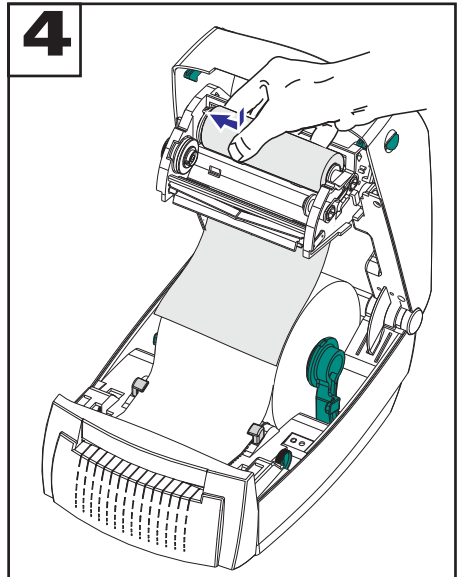
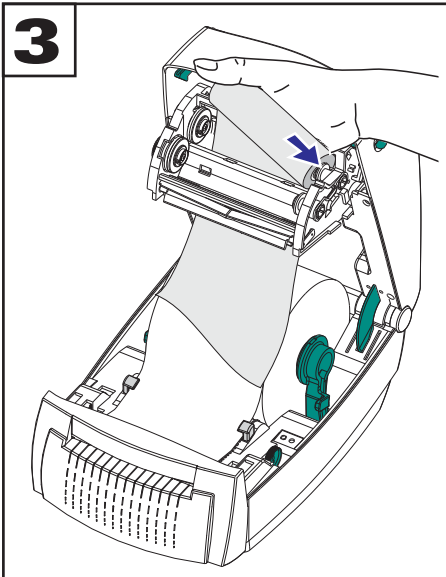
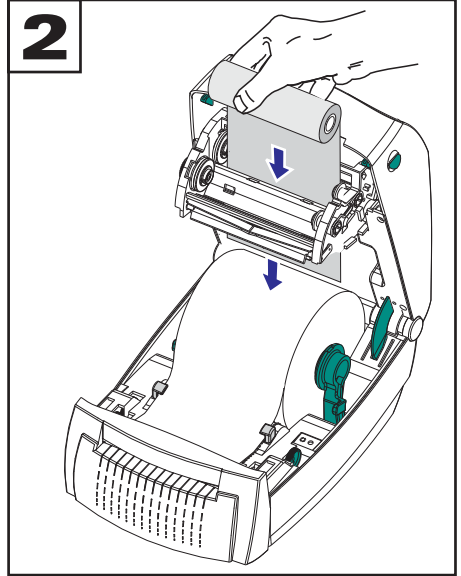
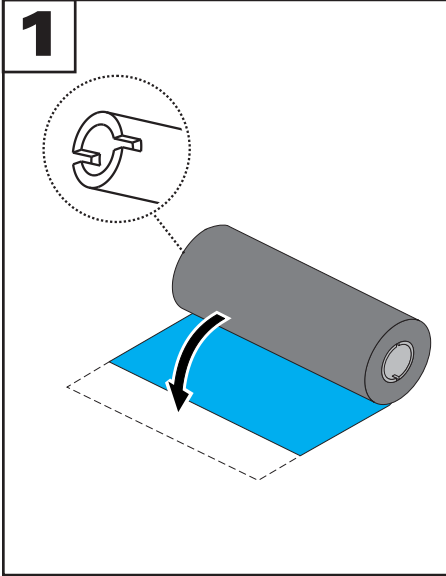
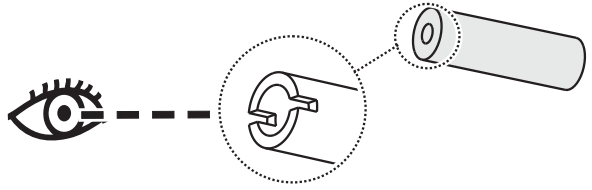



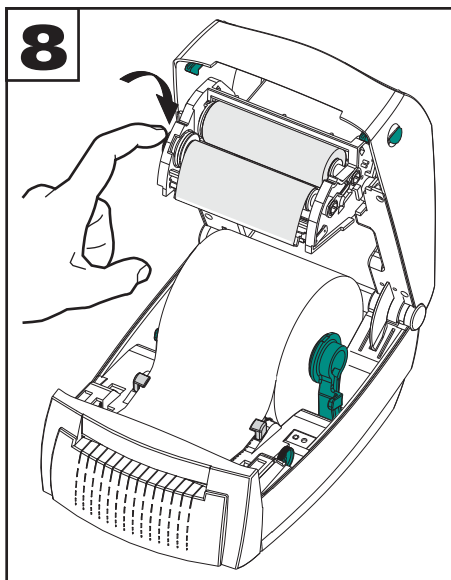
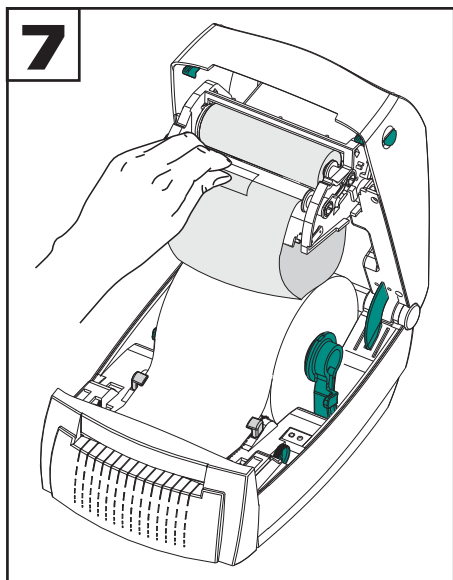
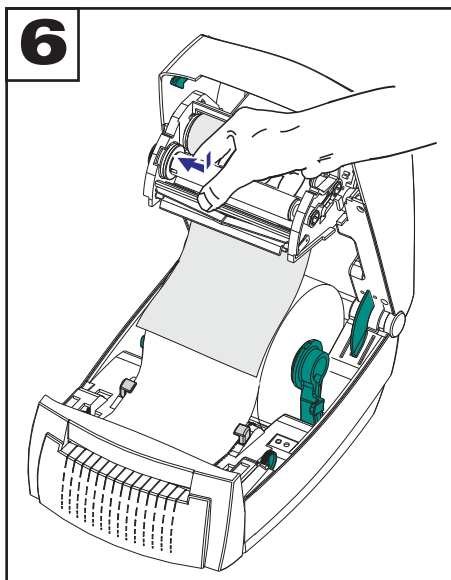
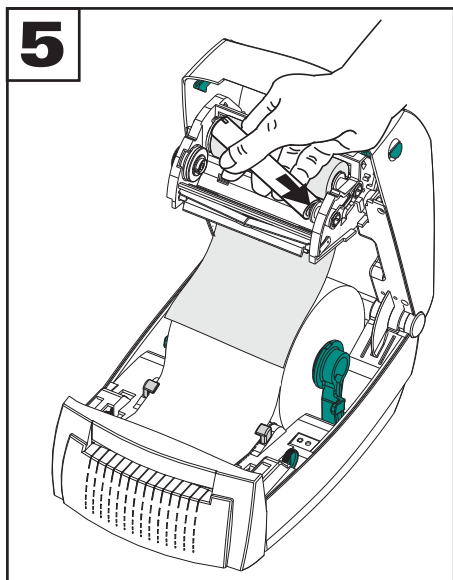
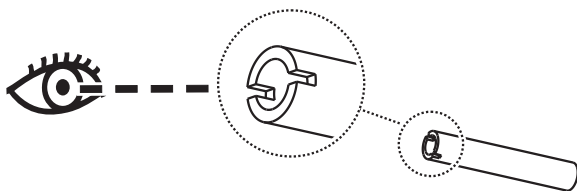

# USB

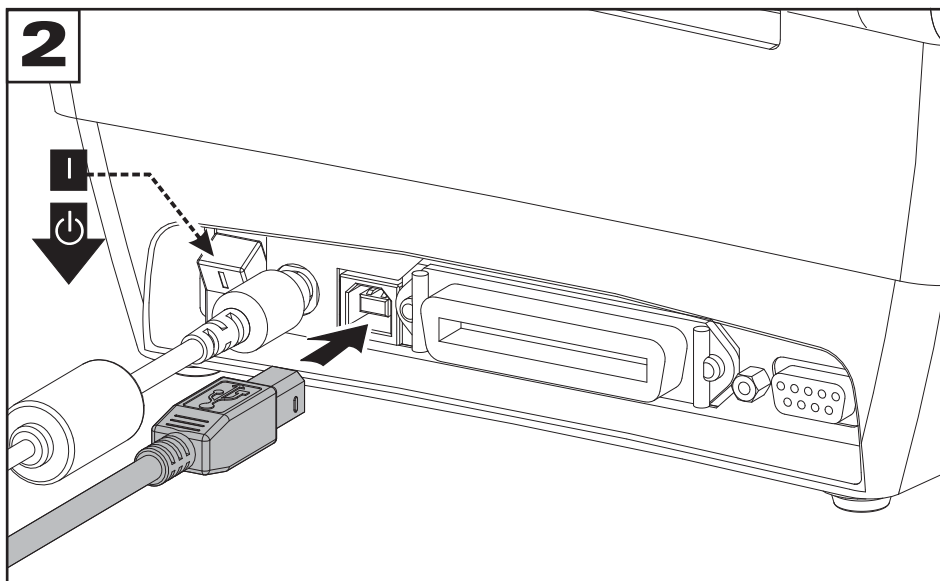
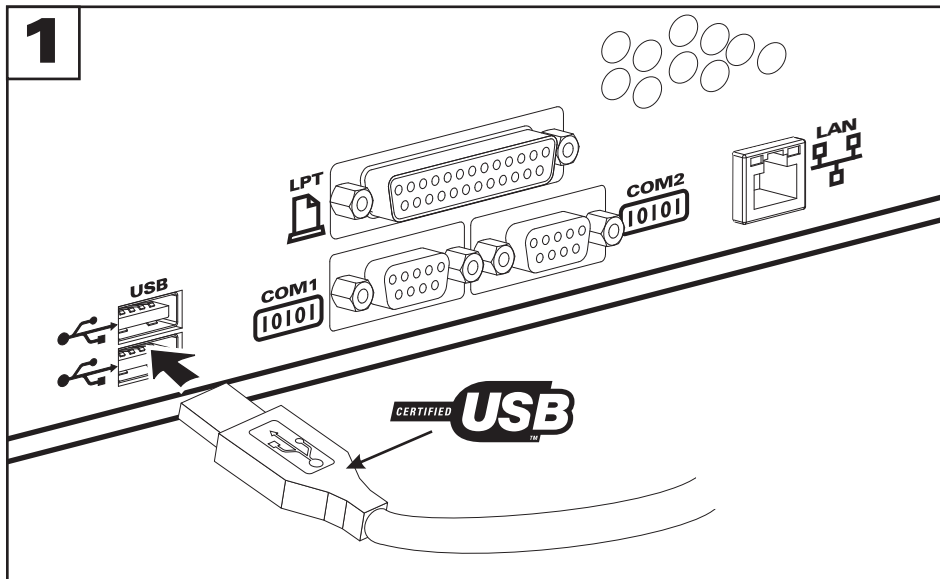
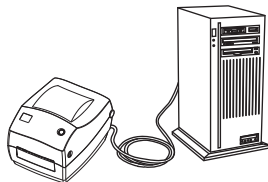

# COM/SER

10101

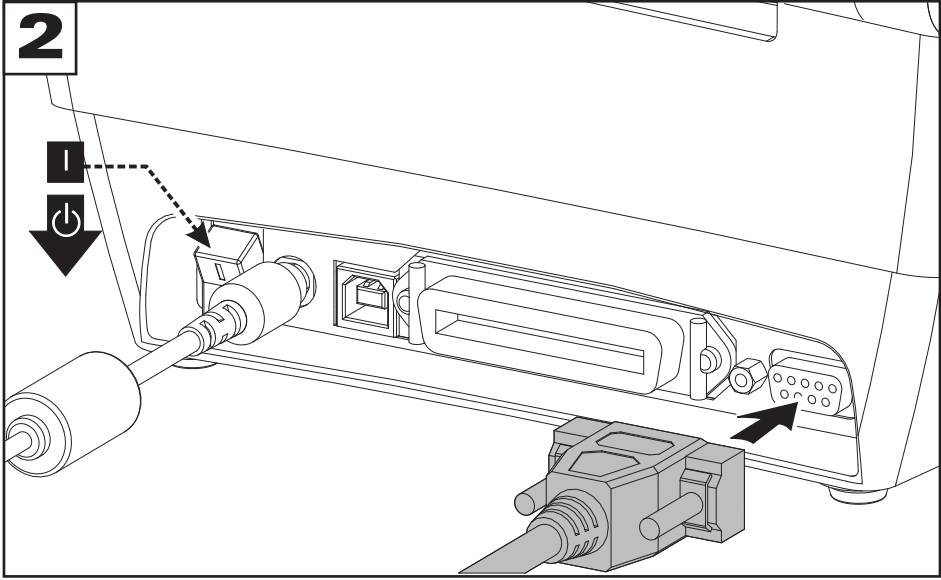
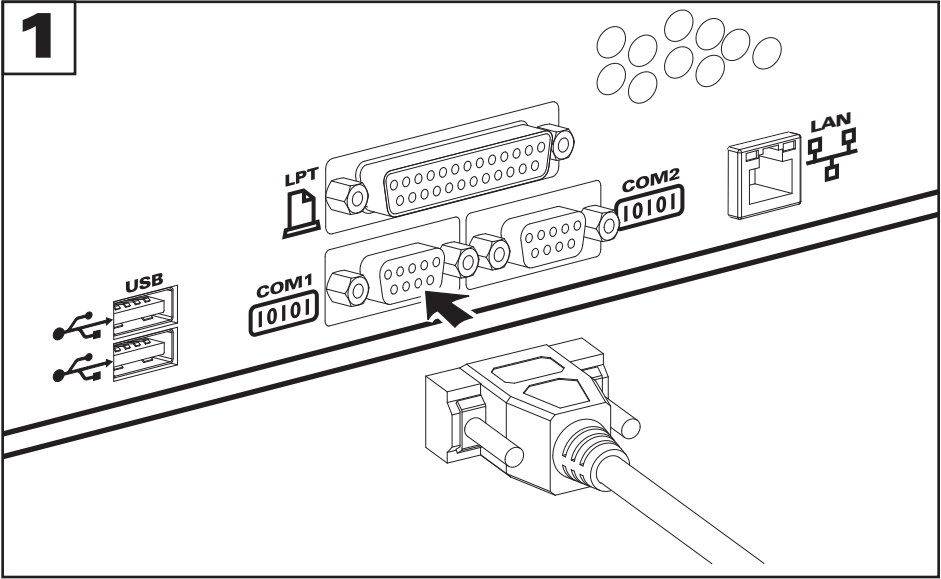
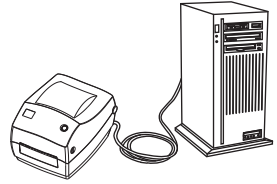

LPT

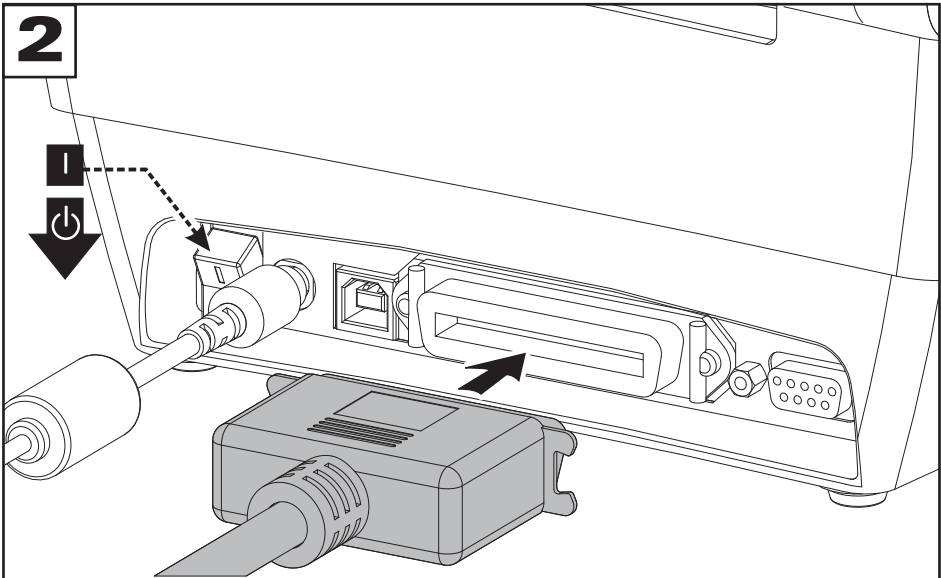
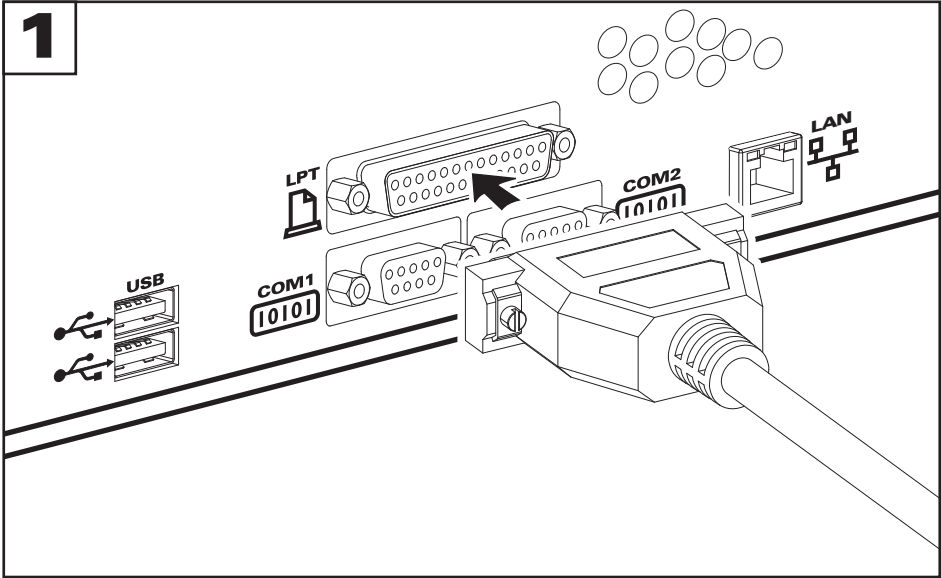
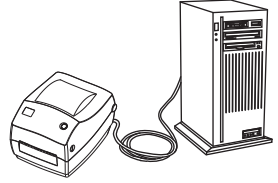

# LAN

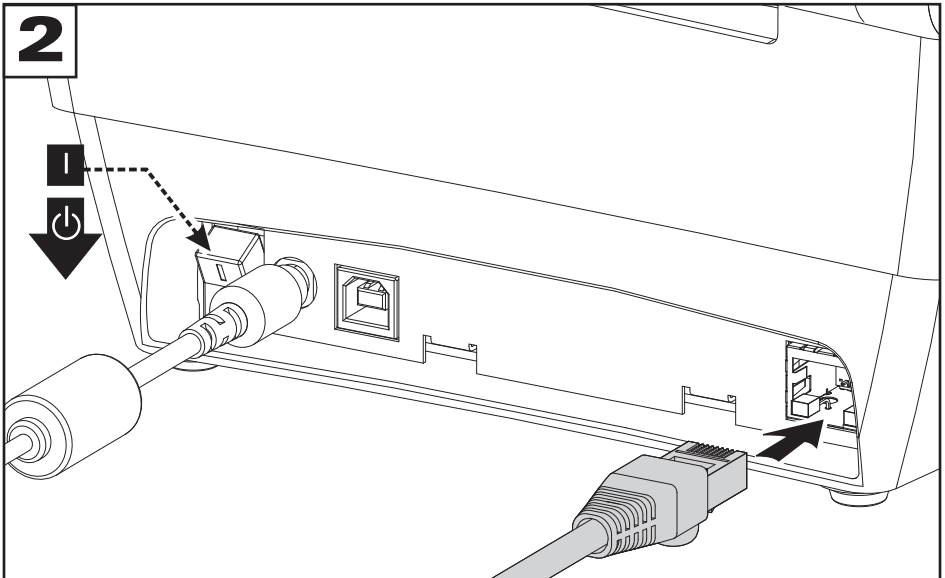
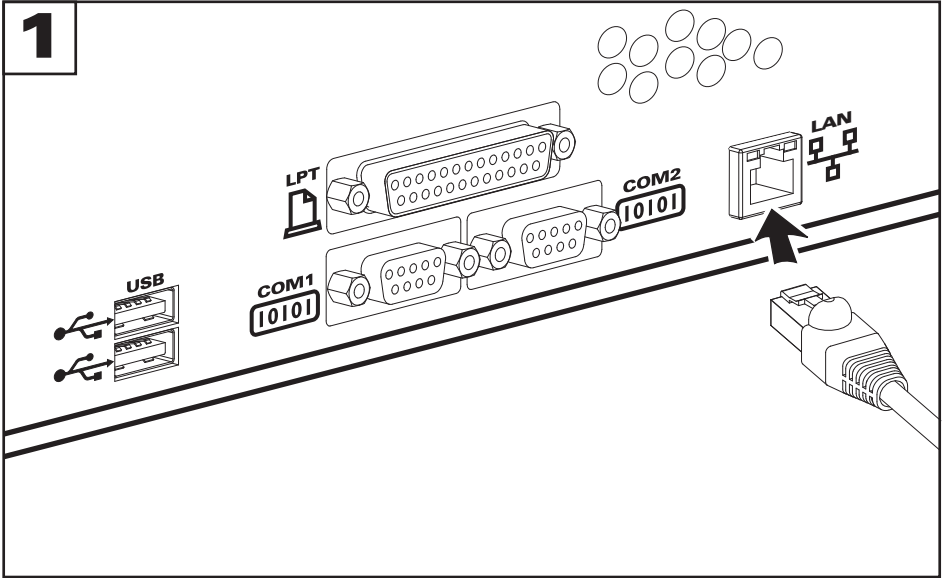
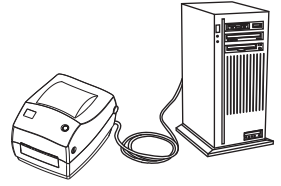
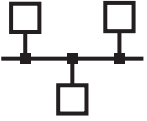

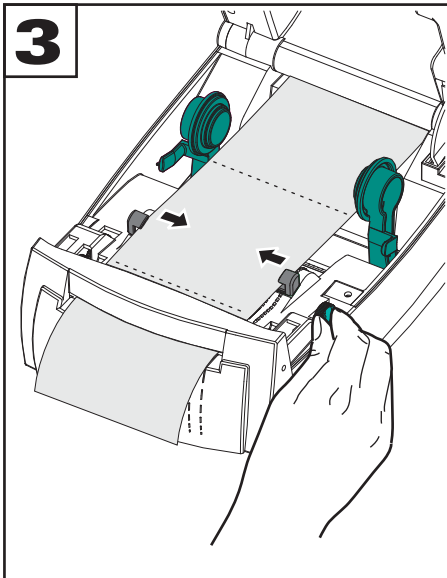
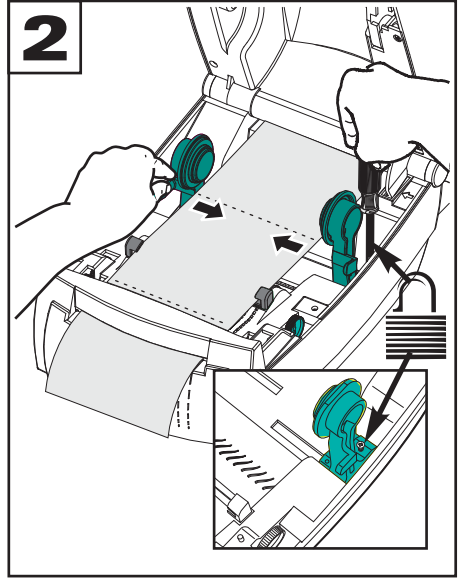
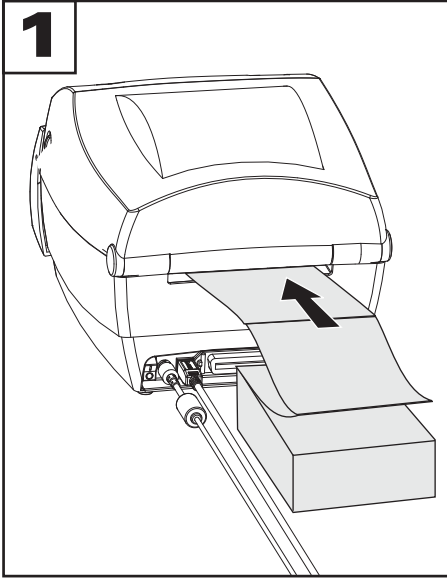
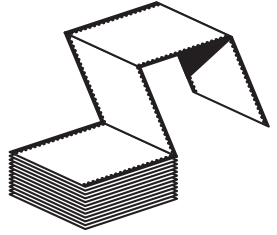



**FCC - DECLARATION OF CONFORMITY:**

Model: GC420t conforms to the following specification: FCC Part 15, Subpart B, Section 15.107(a) and Section 15.109(a) Class B digital device

Supplemental Information: This device complies with Part 15 of the FCC Rules. Operation is subject to the following Two Conditions: (1) This device may not cause harmful interference, and (2) this device must accept any interference received, including interference that may cause undesired operation.

The user is cautioned that any changes or modifications not expressly approved by Zebra Technologies could void the user's authority to operate the equipment. To ensure compliance, this printer must be used with shielded communication cables.

Use only power supplies listed in this manual and/or recommended and approved by Zebra Technologies.

**INDUSTRY CANADA NOTICE:**

This device complies with Industry Canada ICES-003 class B requirements.

Cet équipement est conforme a NMB-003 classe B de la norm Industrielle Canadian.



Utilice sólo adaptadores con las siguientes características eléctricas y que estén debidamente certificados de acuerdo a la legislación vigente. El uso de otros adaptadores podría dañar el dispositivo y anular la garantía además de provocar riesgos al usuario.

Características de entrada: 100-240V; 50-60Hz; 2,0A

Características de salida: 20Vdc; 2,5A



Es dürfen nur zugelassene Adapter mit den folgenden elektrischen Kennzeichen benutzt werden. Die Verwendung anderer Adapter könnte die Vorrichtung beschädigen oder den Benutzer gefährden.

Nennwerte: Eingang: 100-240VAC, 50-60Hz, 2,0A

Ausgang: 20VDC, 2,5A



**사용자 안내문**

B급기기(가정용 정보통신기기)

이 기기는 가정용으로 전자파적합등록을 한 기기로서 주거지역에서는 물론 모든 지역에서 사용할 수 있습니다.

기기의 명칭/(모델명)

인쇄 기계 GC420t

인증받은자의 상호

Zebra Technologies International LLC

제조사/제조국가

Zebra Technologies Corporation/USA



**Zebra Technologies Corporation**

475 Half Day Road, Suite 500  
Lincolnshire, IL 60069 USA  
Telephone: +1 847 634 6700  
Toll-free: +1 866 230 9494  
Facsimile: +1 847 913 8766



**Zebra Technologies Europe Limited**

Dukes Meadow  
Millboard Road  
Bourne End  
Buckinghamshire SL8 5XF, UK  
Telephone: +44 (0)1628 556000  
Facsimile: +44 (0)1628 556001



**Zebra Technologies Asia/Pacific, Pte. Ltd.**

120 Robinson Road  
#06-01 Parakou Building  
Singapore 068913  
Telephone: +65 6858 0722  
Facsimile: +65 6885 0838



P1038982- 001



**Printed on  
chlorine-free  
recycled paper.**

Printed in